



# Submittal Package

---

## QRW1 Drainage EIFS

*Project:*

*Location:*

*Architect:*

*General Contractor:*

*Applicator:*

### *Benefits of Master Wall*

- American owned and privately managed, our focus is the customer
- 20+ year track record, projects from coast to coast
- Quality products featuring 100% pure acrylic polymers
- Dedicated to the EIFS & Stucco Markets, it's **what** we do, not part of what our company does
- Experienced Staff—100+ years of experience
- Service—we provide it!
  - Job site visits
  - Color matching
  - Architectural Support
  - Samples
  - Plan, detail and technical reviews
- Dedicated to a culture of excellence

More Information



QRW1 Drainage EIFS

### *Submittal Information:*

- *System Data Sheets*
- *Product Data Sheets*
- *Specifications*
- *Details*
- *Sample Labor/Material Limited Warranty*

Manufactured by



P. O. Box 397  
Fortson, GA 31808  
800-755-0825  
Technical 800-760-2861  
[www.masterwall.com](http://www.masterwall.com)



07 24 19

# QRW1 Drainage EIFS

Drainage Type Exterior Insulation and Finish System

*Master Wall's QRW1 System is a durable drainage system made for residential & light commercial construction. Its large insulation boards install easily and quickly over an approved water barrier. QRW1 may also use optional vent spacers or drainage mats for improved drainage.*

## Features & Benefits

- 98% Drainage Efficiency
- High Insulating Value (R-5 per inch)
- Easy Application

### System Uses

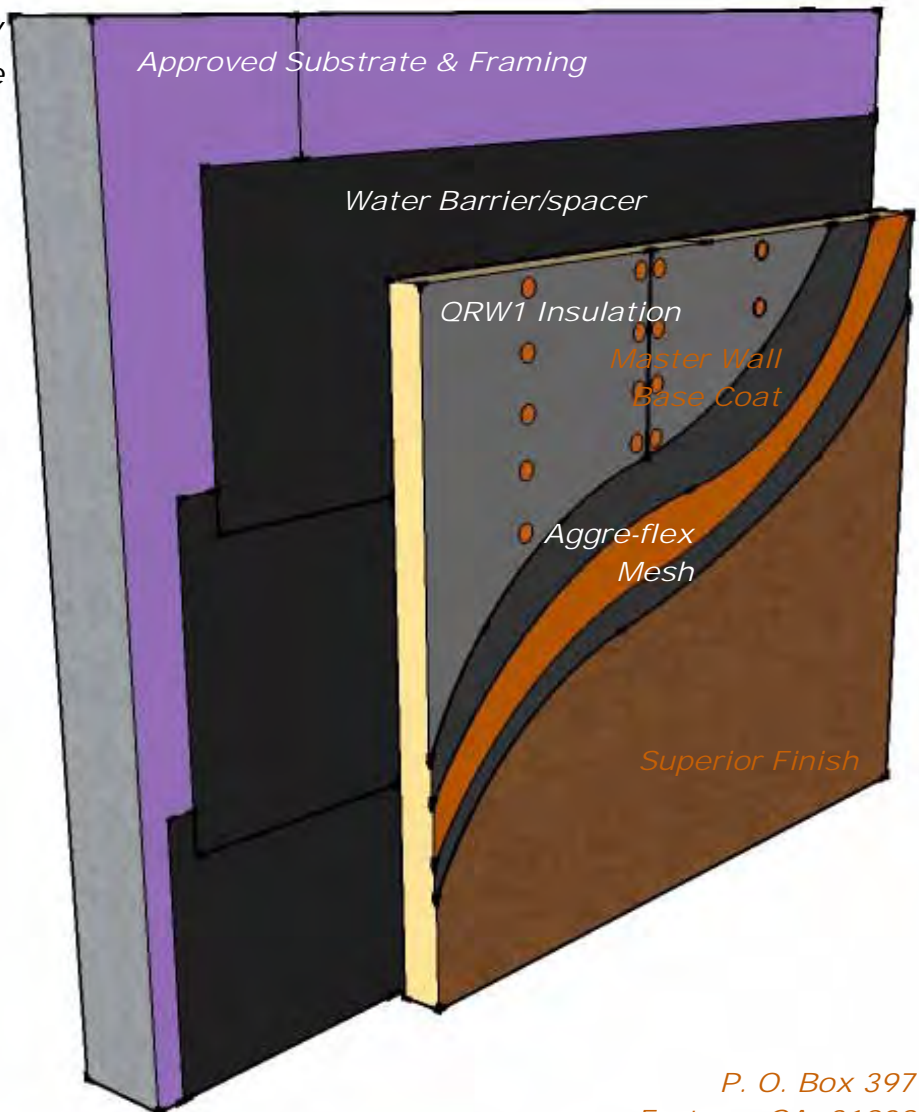

©2011 Master Wall Inc.

P. O. Box 397  
 Fortson, GA 31808  
 800-755-0825  
 Technical 800-760-2861  
 masterwall.com

050111

## 1.0 General

This is a short form specification. Refer to QRW1 Drainage specifications and details for additional information.

### 1.1 System Description

The Master Wall QRW1 Drainage Exterior Insulation and Finish System (EIFS) is a Class PI EIF System consisting of mechanical attachment, insulation board, reinforcing mesh and a textured finish.

### 1.2 Design Requirements:

- A. Reference Master Wall suggested details and architectural drawings for specific detail requirements.
- B. Slope all surfaces a minimum of 1:2 (6" in 12") to shed water, maximum 12" (305mm) wide.
- C. Maximum deflection of substrates shall not exceed L/240.
- D. Typical acceptable substrates include painted or unpainted brick, unit masonry, concrete, stucco brown coat, exterior grade gypsum sheathing (ASTM C-79), Dens Glass Gold<sup>®</sup> (ASTM C-1177), CDX exterior grade plywood, Exposure 1 Oriented Strand Board (OSB). Contact Master Wall for other approved substrates.
- E. A code-approved weather-resistive barrier is required over the substrate.
- F. Expansion joints are required at building expansion joints, panel joints, floor lines in wood framed construction, and other areas where significant movement occurs.
- G. Control joints are required to be located by the designer. Reference Master Wall specifications for specific recommendations.
- H. Detail and install trim accessories according to the approved trim manufacturer's requirements (Plastic Components, Vinyl Corp. or approved equal).

### 1.3 Quality Assurance

- A. The system shall be tested for: Accelerated weathering, mildew resistance, salt spray resistance and structural performance.
- B. The system shall have been tested for fire performance in accordance with ASTM E-84.

## 1.4 Job Conditions

- A. Store all materials protected from weather and direct sunlight at temperatures above 40°F (5°C).
- B. The ambient and wall temperature shall be a minimum of 40°F (5°C) and shall remain so for at least 24 hours after installation.

## 2.0 Products

All components of the QRW1 Drainage System shall be manufactured by Master Wall and supplied by an authorized distributor.

- A. Master Wall Approved Fasteners: Wind-Lock ULP-402 washer and appropriate fastener or approved equal.
- B. Polyisocyanurate Insulation Board: Thermax Quik-R by Dow or Stucco Shield II by Atlas Energy Products Division or Master Wall approved equal.
- C. Aggre-flex Mesh: Available in Standard, Detail, Hi-Tech, Medium, Strong and Ultra.
- D. Master Wall Base Coats:
  1. F&M Plus: A high-build 100% pure acrylic-based fiber reinforced adhesive that is field mixed with Portland cement.
  2. Master Wall Bagged Base (MBB): A ready to use dry base that is field mixed with water.
  3. EPSB: A ready to use non-cement acrylic copolymer base coat.
- E. Superior Finish: 100% pure acrylic formulation with integral color and texture. Perfect, Spray, Desert Sand, R-Coarse and Refinish textures.
- F. Master Wall Coatings:
  1. Primecoat: A water-based primer.
  2. Sanded Primecoat: Sanded water-based primer.
  3. Roller-flex: A water-based architectural finish coating.

## 3.0 Installation

- A. Inspect the substrate to ensure that it is free of all foreign materials that would affect the application of the QRW1 Drainage System.
- B. Apply the system in strict accordance with Master Wall specifications, product data sheets, architectural drawings and architectural specifications.

See full specifications and  
details at [masterwall.com](http://masterwall.com)

# SUPERIOR *finishes*

*Integrally Colored Textured Acrylic Finishes*



*Perfect Texture*



*Spray Texture*



*Desert Sand Texture*



*R-Coarse Texture*



*Refinish Texture*



**M Master Wall Inc.**  
*Building a Culture of Excellence*



Superior Finish is Master Wall's textured finish line. Available in standard or custom colors, Superior Finishes may be applied over Master Wall Base Coats or prepared substrates including brick, masonry, concrete and stucco. Superior Finishes work great for interior applications as well. Superior Finish is available in five-gallon (19L) pails and is typically troweled onto the wall surface with a stainless steel trowel.

### Estimated Coverage

Perfect: 120-150 sf/pail (11-14 sm)  
 Spray SS: 215-225 sf/pail (20-21 sm)  
 Desert Sand SS: 130-150 sf/pail (12-14 sm)  
 R-Coarse: 90-120 sf/pail (8.4-11 sm)  
 Perfect West: 140-160 sf/pail (13-15 sm)  
 Refinish: Varies with Texture

Coverage will vary by application, applicator skill and substrate conditions. Master Wall assumes no responsibility nor liability for coverage.

### Finish Properties

Meets or Exceeds:  
 ASTM E84 Surface Burning  
 ASTM E108 Flame Spread  
 ASTM C67 Freeze/Thaw  
 ASTM E2485/2570 Freeze/Thaw  
 ASTM D2247/E2570 Humidity  
 ASTM D3273 Mold/Mildew  
 ASTM D968 Abrasion  
 ASTM B117 Salt Spray  
 ASTM G53 Weathering  
 ASTM G23/G154/G155 Weathering

### Approved Substrates

Master Wall Base Coats  
 Stucco  
 Prepared & Base Coated Surfaces of:  
 Brick  
 Concrete  
 Masonry  
 Others approved in writing

### Statistics

Pail Weight: 70 lbs (32 kg), Refinish 65 lbs (29.5 kg)

Working Time: 1/4 hour @ room temperature

Drying Time: 8-12 hours to set, 48-72 hours to dry @ room temperature. High pigment levels, low temperatures, high humidity extend dry times.

Application Range: 40°-110°F (5°-43°C)

Shelf Life: 2 years

### Application Procedure

**Job Conditions** - Air and substrate temperature for application of Superior Finishes must be 40°F (5°C) or higher and must remain 40°F (5°C) or higher for a minimum of 24 hours. Provide temporary protection to protect the wall system from damage until permanent flashings, caps and sealants are installed. Store materials within prescribed temperature limits and out of direct sunlight. High temperatures will reduce working times, Low temperatures and/or high humidity will extend working, set and dry times.

**Preparation** - The substrate must be approved by Master Wall Inc., clean, dry, structurally sound and free of efflorescence, oil, grease, form release agents and curing compounds or anything that would affect bond. Painted surfaces are not acceptable and must be removed. Concrete and surfaces should cure for a minimum of 28 days. Stucco should be cured until clean, dry and hard—typically 14 days.

Interior drywall should be finished and made ready for paint. Prime surfaces with Primecoat/Sanded Primecoat primer prior to finishing.

**Base Coats** - Must be flat, dry hard, and free of efflorescence. Master Wall base coats must cure a minimum of 12 hours before application of Superior Finish. Substrates of brick, masonry or concrete should be leveled smooth using either Master Wall base coats or stucco.

**Mixing** - Thoroughly stir Superior Finish using a heavy duty 1/2" drill at 400 - 500 rpm and a heavy duty mixing paddle. Small amounts of clean, potable water may be added to obtain a workable consistency. To avoid color variations, add the same amount of water to each pail. Do not exceed 24 ounces (0.7L) of water per pail of finish.

**Application** — Apply a uniform thickness (about 1/16") of Superior Finish to the substrate using a stainless steel trowel. Spread evenly and then scrape the finish coat down to a thickness no greater than the largest aggregate in the material. Immediately float the finish coat using a plastic float to the desired texture. Always maintain a wet edge to achieve uniformity of texture and color.

### For Professional Results

- Apply finish coats away from direct sunlight. Cold joints or color variations can occur if the finish dries too quickly.

- Consider priming stucco surfaces with Primecoat/Sanded Primecoat to even out finish absorption.
- Surfaces exposed to the weather must be sloped (6:12 minimum).
- Under certain conditions dark colors may show efflorescence on the surface during the cure process.
- Finishes are intended for the approved substrates listed above and should not be applied directly to gypsum board or insulation board products.

**Clean Up**—Tools and equipment can be cleaned with soapy water while the Superior Finish is still wet.

### Available Options



Elastomeric Additive



Silicone Additive



Excel Mildew Additive



**Master Wall Inc.**  
 Building a Culture of Excellence

P. O. Box 397  
 Fortson, GA 31808

800-755-0825

Technical 800-760-2861

masterwall.com

050111

Information contained in this product data sheet conforms to the standard detail recommendations and specifications for the installation of Master Wall Inc. products and is presented in good faith. Master Wall Inc. assumes no liability, expressed or implied as to the architecture, engineering, or workmanship of any project. This information may be concurrent with, or superseded by other applicable documents, such as specifications and details. Contact Master Wall Inc. for the most current product information.



# F&M Plus



*F&M Plus is the high-build version of our Foam & Mesh*

## High Build Foam & Mesh

**Adhesive & Base Coat**

*Adhesive (F&M) used in Master Wall Systems*

*or over prepared substrates. Fibered F&M Plus is available in five-gallon (19L) pails and is mixed 1:1 with Portland cement to a creamy consistency. F&M Plus trowels out smoothly with a stainless steel trowel to provide superior leveling capability up to 1/4" (6.4 mm) thickness.*

### **Application Procedure**

**Job Conditions** - Air and substrate temperature for application of *F&M Plus* must be 40°F (5°C) or higher and must remain 40°F (5°C) or higher for a minimum of 24 hours. Provide temporary protection to protect the wall system from damage until permanent flashings, caps and sealants are installed. Store materials within prescribed temperature limits and out of direct sunlight. Working and drying times are based upon normal room temperature conditions and will vary with temperature and humidity.

**Preparation** - The substrate must be approved by Master Wall Inc., clean, dry, structurally sound and free of efflorescence, oil, grease, form release agents and curing compounds or anything that would affect bond. Painted surfaces are not acceptable and must be removed.

**Mixing** - Thoroughly stir *F&M Plus* using a heavy duty 1/2" (12.7 mm) drill at 400 - 500 rpm and a heavy duty mixing paddle. Pour half of the stirred *F&M Plus* into a clean plastic pail. Add Type I or I-II Portland cement to the half pail of *F&M Plus* in a ratio of one-to-one by weight and mix to a homogenous consistency. Let the mixture stand for 3 to 5 minutes and then stir to a creamy consistency. Up to 30 ounces (0.9L) of clean, potable water may be added to a half pail to adjust workability. Do not over mix as faster setting or reduced working time can occur. Do not add accelerators or retarders to the *F&M Plus* mixture.

### **Application**

Adhesive application – Over gypsum substrates, apply the *F&M* mixture directly to the back of the insulation board using a 3/8"x3/8"x3/8" (9.5x9.5x9.5 mm) or a 3/8"x1/2"x1-1/2" (9.5x13x38 mm) stainless steel notched trowel. With the trowel at a 45° angle, cover the entire back of the insulation board with full beads of adhesive. Apply the adhesive so the ribbons run vertically when applied to the wall.

Over non-gypsum substrates, you may use the above described notched trowel method or the 'ribbon and dab' method. Using a stainless steel plastering trowel, apply a 2" (50.8 mm) wide by 3/8" (9.5 mm) high ribbon of the *F&M Plus* mixture around the entire perimeter of the insulation board. Place 8 dabs of the *F&M Plus* mixture 3/8" (9.5 mm) thick by 4" (102 mm) in diameter approximately 8" (204 mm) on center inside the ribbon.

Immediately place the prepared insulation board on the substrate. Make sure that all edges of the insulation board are abutted tightly and that no *F&M Plus* mixture gets into the board joints. Do not allow the *F&M Plus* mixture to form a skin prior to placing the insulation board on the substrate. Do not apply the *F&M Plus* mixture directly onto the substrate.

For base coat application – All imperfections in the insulation board must be rasped flush and any gaps in the insulation board must be filled with slivers of insulation. Apply the *F&M Plus* mixture over the entire surface of the insulation board or substrate in a thickness greater than that of the reinforcing fabric being used (approximately 1/16" (1.6 mm) for standard mesh and 3/32" (2.4 mm) for Ultra Mesh). Immediately embed the reinforcing fabric into the wet *F&M Plus* mixture and smooth from the center to the edge to avoid wrinkles. The reinforcing fabric must be continuous at all corners and lapped or abutted in accordance to Master Wall specifications. The color of the mesh shall not be visible but a slight mesh pattern may be visible.

### **Statistics**

#### **Coverage (Estimated/varies)**

Adhesive & Standard Base: 120 sf (11 sm)  
Single Layer Mesh Only : 240-280 sf (22-26 sm)  
Double Layer Mesh Only: 80-230 sf (7.5-21 sm)  
Notched Trowel Only: 135 sf (12.5 sm)  
  
Pail Weight: 60 lbs (27kg)

Working Time: 1 hour @ room temperature  
Drying Time: 12 hours @ room temperature  
Application Range: 40°-110°F (5°-43°C)  
Shelf Life: 2 years

**Clean Up**—Tools and equipment can be cleaned with soapy water while the *F&M Plus* is still wet.



Information contained in this product data sheet conforms to the standard detail recommendations and specifications for the installation of Master Wall Inc. products and is presented in good faith. Master Wall Inc. assumes no liability, expressed or implied as to the architecture, engineering, or workmanship of any project. This information may be concurrent with, or superseded by other applicable documents, such as specifications and details. Contact Master Wall Inc. for the most current product information.

### **Approved Substrates**

- Exterior gypsum sheathing (ASTM C79, C1177)
- Dens Glass Gold®
- GlasRoc®
- FiberBond®
- Gold Bond e<sup>2</sup>xp®
- Securock®
- Durock®
- PermaBase®
- Util-A-Crete®, ProTEC®, ProGUARD®
- Concrete
- Brick
- Masonry
- Metal Lath
- Others approved in writing



# MBB Plus



Master Wall MBB Plus is a single-component polymer

## Master Wall Bagged Base

High Build Adhesive & Base Coat

modified high build dry bagged

base coat and adhesive that is mixed with water at time of use. Use MBB Plus in Master Wall Systems or over prepared substrates including brick, masonry, concrete and stucco. MBB Plus is freeze stable in dry form mixes to a creamy consistency.

### Approved Substrates

- Exterior gypsum sheathing (ASTM C79)
- Dens Glass Gold®
- GlasRoc®
- FiberBond®
- Gold Bond e<sup>2</sup>xp®
- Durock®
- PermaBase®
- Util-A-Crete®, ProTEC®, ProGUARD®
- Concrete
- Brick
- Masonry
- Metal Lath
- Others approved in writing

### Application Procedure

**Job Conditions** - Air and substrate temperature for application of MBB Plus must be 40°F (5°C) or higher and must remain 40°F (5°C) or higher for a minimum of 24 hours. Provide temporary protection to protect the wall system from damage until permanent flashings, caps and sealants are installed. Store materials within prescribed temperature limits and out of direct sunlight. Working and drying times are based upon normal room temperature conditions and will vary with thickness, temperature and humidity.

**Preparation** - The substrate must be approved by Master Wall Inc., clean, dry, structurally sound and free of efflorescence, oil, grease, form release agents and curing compounds or anything that would affect bond. Painted surfaces are not acceptable and must be removed.

**Mixing** - Add 5 to 6 quarts (4.7-5.7L) of potable water to a clean plastic pail. Add the MBB Plus slowly while stirring using a heavy-duty 1/2" (12.7 mm) drill at 400 - 500 rpm and a heavy-duty Mixer. Mix thoroughly to a homogenous consistency. Let the mixture stand for 3 to 5 minutes and then stir to a creamy consistency. Small amounts of clean, potable water may be added to obtain a workable consistency. Do not over mix. Excessive stirring may cause faster setting and reduced working time. Do not add accelerators or retarders to the MBB Plus mixture.

### Application

**Adhesive Application** - Over gypsum substrates, apply the F&M mixture directly to the back of the insulation board using a 3/8"x3/8"x3/8" (9.5x9.5x9.5 mm) or a 3/8"x1/2"x1-1/2" (9.5x13x38 mm) stainless steel notched trowel. With the trowel at a 45° angle, cover the entire back of the insulation board with full beads of adhesive. Apply the adhesive so the ribbons run vertically when applied to the wall.

**Masonry Substrates (non-drainage)** - Use the above described notched trowel method or the 'ribbon and dab' method. Using a stainless steel plastering trowel, apply a 2" (50.8 mm) wide by 3/8" (9.5 mm) high ribbon of the MBB Plus mixture around the entire perimeter of the insulation board. Place 8 dabs of the MBB Plus mixture 3/8" (9.5 mm) thick by 4" (102 mm) in diameter approximately 8" (204 mm) on center inside the ribbon.

Immediately place the prepared insulation board on the substrate. Make sure that all edges of the insulation board are abutted tightly and that no MBB Plus mixture gets into the board joints. Do not allow the MBB Plus mixture to form a skin prior to placing the insulation board on the substrate. Do not apply the MBB Plus mixture directly onto the substrate.

**Base Coat Application** - All imperfections in the insulation board must be rasped flush and any gaps in the insulation board must be filled with slivers of insulation. Apply the MBB Plus mixture over the entire surface of the insulation board or approved substrate in a thickness greater than that of the reinforcing fabric being used (approximately 1/16" (1.6 mm) for standard mesh and 3/32" (2.4 mm) for Ultra Mesh).

### Statistics

#### Coverage (Estimated/Varies)

Adhesive & Standard Base: 50-60 sf (4.6-5.6 sm)

Single Layer Mesh Only : 100-125 sf (9-11.5 sm)

High Build (1/8"): 50-60 sf (4.6-5.6 sm)

Notched Trowel Only: 56 sf (5.2 sm)

Bag Weight: 50 lbs (22.7kg)

Working Time: 1 hour @ room temperature

Drying Time: 12 hours @ room temperature

Application Range: 40°-110°F (5°-43°C)

Shelf Life: 1 year

Immediately embed the reinforcing fabric into the wet MBB Plus mixture and smooth from the center to the edge to avoid wrinkles. The reinforcing fabric must be continuous at all corners and lapped or abutted in accordance to Master Wall specifications. The color of the mesh shall not be visible but a slight mesh pattern may be visible.

**Clean Up**—Tools and equipment can be cleaned with soapy water while the MBB Plus is still wet.



Information contained in this product data sheet conforms to the standard detail recommendations and specifications for the installation of Master Wall Inc. products and is presented in good faith. Master Wall Inc. assumes no liability, expressed or implied as to the architecture, engineering, or workmanship of any project. This information may be concurrent with, or superseded by other applicable documents, such as specifications and details. Contact Master Wall Inc. for the most current product information.

P. O. Box 397  
Fortson, GA 31808  
800-755-0825  
Technical 800-760-2861  
www.masterwall.com



*Foam & Mesh Adhesive (F&M) is a high performance base coat and adhesive used in Master Wall Systems or over prepared substrates including brick, masonry, concrete and stucco. F&M is available in five-gallon (19L) pails and is mixed 1:1 with Portland cement to a creamy consistency. F&M trowels out smoothly with a stainless steel trowel and is the premium choice for embedding mesh or leveling walls.*

## Foam & Mesh Adhesive & Base Coat

### Application Procedure

**Job Conditions** - Air and substrate temperature for application of F&M must be 40°F (5°C) or higher and must remain 40°F (5°C) or higher for a minimum of 24 hours. Provide temporary protection to protect the wall system from damage until permanent flashings, caps and sealants are installed. Store materials within prescribed temperature limits and out of direct sunlight. Working and drying times are based upon normal room temperature conditions and will vary with temperature and humidity.

**Preparation** - The substrate must be approved by Master Wall Inc., clean, dry, structurally sound and free of efflorescence, oil, grease, form release agents and curing compounds or anything that would affect bond. Painted surfaces are not acceptable and must be removed.

**Mixing** - Thoroughly stir F&M using a heavy duty 1/2" (12.7 mm) drill at 400 - 500 rpm and a heavy duty mixing paddle. Pour half of the stirred F&M into a clean plastic pail. Add Type I or I-II Portland cement to the half pail of F&M in a ratio of one-to-one by weight and mix to a homogenous consistency. Let the mixture stand for 3 to 5 minutes and then stir to a creamy consistency. Up to 30 ounces (0.9L) of clean, potable water may be added to a half pail to adjust workability. Do not over mix as faster setting or reduced working time can occur. Do not add accelerators or retarders to the F&M mixture.

### Application

Adhesive application – Over gypsum substrates, apply the F&M mixture directly to the back of the insulation board using a 3/8"x3/8"x3/8" (9.5x9.5x9.5 mm) or a 3/8"x1/2"x1-1/2" (9.5x13x38 mm) stainless steel notched trowel. With the trowel at a 45° angle, cover the entire back of the insulation board with full beads of adhesive. Apply the adhesive so the ribbons run vertically when applied to the wall.

Over non-gypsum substrates, you may use the above described notched trowel method or the 'ribbon and dab' method. Using a stainless steel plastering trowel, apply a 2" (50.8 mm) wide by 3/8" (9.5 mm) high ribbon of the F&M mixture around the entire perimeter of the insulation board. Place 8 dabs of the F&M mixture 3/8" (9.5 mm) thick by 4" (102 mm) in diameter approximately 8" (204 mm) on center inside the ribbon.

Immediately place the prepared insulation board on the substrate. Make sure that all edges of the insulation board are abutted tightly and that no F&M mixture gets into the board joints. Do not allow the F&M mixture to form a skin prior to placing the insulation board on the substrate. Do not apply the F&M mixture directly onto the substrate.

For base coat application – All imperfections in the insulation board must be rasped flush and any gaps in the insulation board must be filled with slivers of insulation. Apply the F&M mixture over the entire surface of the insulation board in a thickness greater than that of the reinforcing fabric being used (approximately 1/16" (1.6 mm) for standard mesh and 3/32" (2.4 mm) for Ultra Mesh). Immediately embed the reinforcing fabric into the wet F&M mixture and smooth from the center to the edge to avoid wrinkles. The reinforcing fabric must be continuous at all corners and lapped or abutted in accordance to Master Wall specifications. The color of the mesh shall not be visible but a slight mesh pattern may be visible.

### Statistics

#### Coverage (Estimated/Varies)

Adhesive & Standard Base: 120 sf (11 sm)  
 Single Layer Mesh Only : 240-280 sf (22-26 sm)  
 Double Layer Mesh Only: 80-230 sf (7.5-21 sm)  
 Notched Trowel Only: 135 sf (12.5 sm)

Pail Weight: 60 lbs (27kg)

Working Time: 1 hour @ room temperature

Drying Time: 12 hours @ room temperature

Application Range: 40°-110°F (5°-43°C)

Shelf Life: 2 years

**Clean Up**—Tools and equipment can be cleaned with soapy water while the F&M is still wet.

### Approved Substrates

- Exterior gypsum sheathing (ASTM C79, C1177)
- Dens Glass Gold®
- GlasRoc®
- FiberBond®
- Gold Bond e<sup>2</sup>xp®
- Securock®
- Durock®
- PermaBase®
- Util-A-Crete®, ProTEC®, ProGUARD®
- Concrete
- Brick
- Masonry
- Metal Lath
- Others approved in writing



Information contained in this product data sheet conforms to the standard detail recommendations and specifications for the installation of Master Wall Inc. products and is presented in good faith. Master Wall Inc. assumes no liability, expressed or implied as to the architecture, engineering, or workmanship of any project. This information may be concurrent with, or superseded by other applicable documents, such as specifications and details. Contact Master Wall Inc. for the most current product information.

P. O. Box 397  
 Fortson, GA 31808  
 800-755-0825  
 Technical 800-760-2861  
[www.masterwall.com](http://www.masterwall.com)



*Master Wall Bagged Base (MBB) is a dry version of*

## Master Wall Bagged Base Adhesive & Base Coat

*our Foam & Mesh Adhesive (F&M). Use MBB as an adhesive or base coat in Master Wall Systems or over prepared substrates including brick, masonry, concrete and stucco. MBB is freeze stable in dry form and is easily mixed with clean potable water to a creamy consistency.*

### Application Procedure

**Job Conditions** - Air and substrate temperature for application of *MBB* must be 40°F (5°C) or higher and must remain 40°F (5°C) or higher for a minimum of 24 hours. Provide temporary protection to protect the wall system from damage until permanent flashings, caps and sealants are installed. Store materials within prescribed temperature limits and out of direct sunlight. Working and drying times are based upon normal room temperature conditions and will vary with temperature and humidity.

**Preparation** - The substrate must be approved by Master Wall Inc., clean, dry, structurally sound and free of efflorescence, oil, grease, form release agents and curing compounds or anything that would affect bond. Painted surfaces are not acceptable and must be removed.

**Mixing** - Add 5 to 6 quarts (4.7-5.7L) of potable water to a clean plastic pail. Add the *MBB* slowly while stirring using a heavy-duty 1/2" (12.7 mm) drill at 400 - 500 rpm and a heavy-duty Mixer. Mix thoroughly to a homogenous consistency. Let the mixture stand for 3 to 5 minutes and then stir to a creamy consistency. Small amounts of clean, potable water may be added to obtain a workable consistency. Do not over mix. Excessive stirring may cause faster setting and reduced working time. Do not add accelerators or retarders to the *MBB* mixture.

### Application

Adhesive application – Over gypsum substrates, apply the *F&M* mixture directly to the back of the insulation board using a 3/8"x3/8"x3/8" (9.5x9.5x9.5 mm) or a 3/8"x1/2"x1-1/2" (9.5x13x38 mm) stainless steel notched trowel. With the trowel at a 45° angle, cover the entire back of the insulation board with full beads of adhesive. Apply the adhesive so the ribbons run vertically when applied to the wall.

Over non-gypsum substrates, you may use the above described notched trowel method or the 'ribbon and dab' method. Using a stainless steel plastering trowel, apply a 2" (50.8 mm) wide by 3/8" (9.5 mm) high ribbon of the *MBB* mixture around the entire perimeter of the insulation board. Place 8 dabs of the *MBB* mixture 3/8" (9.5 mm) thick by 4" (102 mm) in diameter approximately 8" (204 mm) on center inside the ribbon.

Immediately place the prepared insulation board on the substrate. Make sure that all edges of the insulation board are abutted tightly and that no *MBB* mixture gets into the board joints. Do not allow the *MBB* mixture to form a skin prior to placing the insulation board on the substrate. Do not apply the *MBB* mixture directly onto the substrate.

For base coat application – All imperfections in the insulation board must be rasped flush and any gaps in the insulation board must be filled with slivers of insulation. Apply the *MBB* mixture over the entire surface of the insulation board in a thickness greater than that of the reinforcing fabric being used (approximately 1/16" (1.6 mm) for standard mesh and 3/32" (2.4 mm) for Ultra Mesh). Immediately embed the reinforcing fabric into the wet *MBB* mixture and smooth from the center to the edge to avoid wrinkles. The reinforcing fabric must be continuous at all corners and lapped or abutted in accordance to Master Wall specifications. The color of the mesh shall not be visible but a slight mesh pattern may be visible.

### Statistics

#### Coverage (Estimated/varies)

Adhesive & Standard Base: 50-60 sf (4.6-5.6 sm)

Single Layer Mesh Only : 100-125 sf (9-11.5 sm)

Double Layer Mesh Only: 30-110 sf (2.5-10 sm)

Notched Trowel Only: 56 sf (5.2 sm)

Bag Weight: 50 lbs (22.7kg)

Working Time: 1 hour @ room temperature

Drying Time: 12 hours @ room temperature

Application Range: 40°-110°F (5°-43°C)

Shelf Life: 1 year

**Clean Up**—Tools and equipment can be cleaned with soapy water while the *MBB* is still wet.



## Master Wall Inc.

Building a Culture of Excellence

Information contained in this product data sheet conforms to the standard detail recommendations and specifications for the installation of Master Wall Inc. products and is presented in good faith. Master Wall Inc. assumes no liability, expressed or implied as to the architecture, engineering, or workmanship of any project. This information may be concurrent with, or superseded by other applicable documents, such as specifications and details. Contact Master Wall Inc. for the most current product information.

### Approved Substrates

- Exterior gypsum sheathing (ASTM C79)
- Dens Glass Gold®
- GlasRoc®
- FiberBond®
- Gold Bond e<sup>2</sup>xp®
- Durock®
- PermaBase®
- Util-A-Crete®, ProTEC®, ProGUARD®
- Concrete
- Brick
- Masonry
- Metal Lath
- Others approved in writing



# Aggre-flex Mesh



Master Wall Aggre-flex Mesh is a specially woven, **AR Glass Fiber** glass fiber mesh with AR Coating (Alkali Resistive). **Master Wall Systems**

Embedded in Master Wall base coats, Aggre-flex Mesh is the key impact and tensile component in Master Wall EIFS and wall systems. It can also improve crack resistance in Master Wall Stucco Systems or traditional stucco.

## General

### Mesh Properties

ASTM D76, D578, D579, D3659, D4029, D5035, E2098, E2486 MIL-Y-1140

Weave: Leno

Mesh	Weight	Roll Size	Tensile (warp/fill)	Coverage*
<b>Detail</b>	4.5 oz/sy (113 g/sm)	9.5" x 150' (96.5cm x 45.7m)	140/150	119 sf (11 sm)
<b>Standard</b>	4.5 oz/sy (113 g/sm)	38" x 150' (96.5cm x 45.7m)	140/150	475 sf (44.1 sm)
<b>Hi-Tech</b>	6.0 oz/sy (202 g/sm)	38" x 150' (96.5cm x 45.7m)	140/250	475 sf (44.1 sm)
<b>Medium</b>	12.0 oz/sy (313 g/sm)	38" x 75' (96.5cm x 22.8m)	300/500	238 sf (22.1 sm)
<b>Strong</b>	15.4 oz/sy (508 g/sm)	38" x 75' (96.5cm x 22.8m)	350/600	238 sf (22.1 sm)
<b>Ultra</b>	21.0 oz/sy (675 g/sm)	38" x 75' (96.5cm x 22.8m)	750/500	238 sf (22.1 sm)
<b>Corner Roll</b>	9.5 oz/sy (238 g/sm)	9.5" x 150' (96.5cm x 45.7m)	274/274	150 lf (45.7 m)

\*Allow about 10% waste for lapping all meshes (Strong, Ultra and Corner Roll Meshes are butted). Coverage will vary.

## Mesh Types

**Detail Mesh** – super soft, pliable mesh used for backwrapping, special shapes, and detail work.

**Standard Mesh** – Standard weight mesh for wall areas and general detailing.

**Hi-Tech Mesh** – Upgraded heavier weight version of *Standard Mesh* with good workability.

**Medium Mesh** – Extra tough heavy weight mesh. Best for areas of light traffic.

**Strong Mesh** – Great high traffic mesh where impacts are a consideration.

**Ultra Mesh** – Best where abuse is expected. Ultra heavy for high traffic areas.

*Strong Mesh and Ultra Mesh must be used in a two-layer system with Standard Mesh, Hi-Tech Mesh, or Medium Mesh.*

**Corner Roll**– For highly impact resistant corners. Apply under Standard or higher mesh.

## Application Procedure

**Job Conditions** - Air and substrate temperature for application of the *Reinforcing Mesh* must be 40°F (5°C) or higher and must remain 40°F (5°C) or higher for a minimum of 24 hours. Provide temporary protection at all times until the wall system, including flashings, caps, and sealants, is completed to provide protection from climatic conditions and other potential damage.

**Application** - All imperfections in the insulation board must be rasped flush and any gaps in the insulation board must be filled with slivers of insulation. Apply the base coat over the entire surface of the insulation board in a thickness greater than that of the *Reinforcing Mesh* being used, approximately 1/16" (1.6 mm) for Standard Mesh and 3/32" (2.4 mm) for Ultra Mesh. Immediately embed the *Aggre-flex Mesh* into the wet base coat and smooth from the center to the edge to avoid wrinkles. Lap all meshes except Strong Mesh and Ultra Mesh a minimum of 2-1/2" (63.5 mm) on all sides. The reinforcing fabric must be continuous at all corners and lapped or abutted in accordance to Master Wall specifications. The color of the mesh shall not be visible but a slight mesh pattern may be visible. The overall minimum thickness of the base coat should be a nominal 1/16" (1.6 mm) when dry.

When applying **Strong, Ultra or Corner Roll Mesh**, tightly abut all edges and let cure for a minimum of 12 hours. Grind any imperfections with the edge of a stainless steel trowel or grinding stone, taking care not to damage the *Aggre-flex Mesh*, and apply a layer of **Standard Mesh, Hi-Tech Mesh, or Medium Mesh** as per the directions in the preceding paragraph. To minimize wall variations, the lap of the second mesh layer should not coincide with the abutment of the first layer.

### Special Conditions and Recommendations

Apply backwrapping mesh or other approved accessory at all terminations of the insulation board. This includes at the top and bottom of all walls and at all openings.

*Aggre-flex Mesh* may be wrapped from the face of the insulation board onto a foundation or onto the studs of an opening on barrier wall systems. In all cases, the exposed edges of the insulation board must be wrapped with *Aggre-flex Mesh* and base coat or an approved accessory trim.

### Impact ASTM E2486 (Formerly EIMA 101.86)

Standard Mesh	Medium Impact Resistance	50-89 in-lbs (5.7-10.1J)
Hi Tech Mesh	Medium Impact Resistance	50-89 in-lbs (5.7-10.1J)
Medium Mesh	Medium Impact Resistance	50-89 in-lbs (5.7-10.1J)
Medium & Standard	High Impact Resistance	90-150 in-lbs (10.2-17.0J)
Strong & Standard	High Impact Resistance	90-150 in-lbs (10.2-17.0J)
Ultra & Standard	Ultra High Impact Resistance	150+ in-lbs (over17.0J)



Information contained in this product data sheet conforms to the standard detail recommendations and specifications for the installation of Master Wall Inc. products and is presented in good faith. Master Wall Inc. assumes no liability, expressed or implied as to the architecture, engineering, or workmanship of any project. This information may be concurrent with, or superseded by other applicable documents, such as specifications and details. Contact Master Wall Inc. for the most current product information.

P. O. Box 397  
Fortson, GA 31808  
800-755-0825  
Technical 800-760-2861  
masterwall.com



# Fasteners & Plates

## Master Wall Systems

There are a variety of fastening products available today. In fact, there are so many it's difficult to tell what fastener and plate to use with what system. Below is a listing of approved plates for Master Wall EIF Systems along with a screw length calculator.

All fastening systems must be applied according to Master Wall instructions. Please reference the system detail drawings and specifications for approved fastening methods and call Master Wall for any special conditions or questions.

### Approved Plates

Manufacturer	Aggre-flex EIFS Aggre-flex Drainage EIFS	QRW1 Drainage EIFS	Master Wall OCS Fiberstucco (One Coat Stucco) and Cemplaster Stucco*
<b>Buildex</b> <a href="http://www.itwbuildex.com">www.itwbuildex.com</a>	Gridmate PB	Gridmate	Gridmate
<b>Demand Products</b> <a href="http://www.demandproducts.com">www.demandproducts.com</a>	PB Washer PBH Washer Gridmaster Washer	DP300 DP400	DP300 Tab Washer
<b>Wind-Lock</b> <a href="http://www.wind-lock.com">www.wind-lock.com</a>	Wind Devil 2	ULP302 ULP402	ULP302 Lath Lock Bugle Head Screw

\*Plates are optional for standard applications, recommended over continuous insulation.

Wind Devil 2 Plates



ULP 302 & 402 Plates



Lath Lock Plates



P. O. Box 397  
Fortson, GA 31808

800-755-0825

Technical 800-760-2861

[masterwall.com](http://masterwall.com)

Information contained in this product data sheet conforms to the standard detail recommendations and specifications for the installation of Master Wall Inc. products and is presented in good faith. Master Wall Inc. assumes no liability, expressed or implied as to the architecture, engineering, or workmanship of any project. This information may be concurrent with, or superseded by other applicable documents, such as specifications and details. Contact Master Wall Inc. for the most current product information.





## Part 1 General

### 1.01 General

- A. The QRW1 Drainage EIF System is a non-structural cavity wall system designed for use on residential construction or light commercial construction.

### 1.02 SCOPE OF WORK

- A. Provide all materials, labor, and equipment to install the Field Applied and/or Panelized Master Wall Inc. QRW1 Drainage EIF System.
- B. Related Sections:
  - 1. Concrete 03300
  - 2. Unit Masonry 04200
  - 3. Light Gauge Steel Framing 05400
  - 4. Sheathing 06100
  - 5. Sheet Metal Flashing and Trim 07620
  - 6. Sealants 07900
  - 7. Doors and Windows 08000

### 1.03 TERMS / DEFINITIONS

- A. Applicator – The contractor that applies the EIFS.
- B. Base Coat – The material applied to the face of the insulation board and reinforced with one or more layers of mesh to function as the exterior weather barrier.
- C. Base Coat Mixture – A field mixed blend of base coat and Portland cement.
- D. Building Expansion Joint – A joint through the entire building structure designed to accommodate structural movement.
- E. Designer – The person or firm that is responsible to create the plans and specifications for the entire project.
- F. EIFS – Exterior Insulation and Finish System
- G. Expansion Joint – A designed joint in the continuity of a material, assembly, or system, designed to accommodate movement.
- H. Finish Coat – An acrylic based, factory mixed decorative and protective coating that is applied to the base coat.
- I. Insulation Board – Polyisocyanurate foam core board faced with a specially coated glass fiber mat designed as an EIFS substrate. The manufacturer of the insulation board shall be approved by Master Wall Inc.
- J. Reinforcing Mesh – Balanced, open weave, basic glass fiber mesh(es) supplied by the manufacturer of the EIFS, treated for compatibility with other materials of the system, which functions to strengthen the system and adds impact resistance.
- K. Mechanical Fastener – Typically a plastic washer and a mechanical fastener utilized to attach the insulation board to the substrate.
- L. Sheathing – A substrate in a sheet form.
- M. Substrate – The material to which the EIFS is attached.



## 1.04 QUALITY ASSURANCE

### A. Design and Detailing

#### 1. General

- a. Master Wall Inc.'s current published details, specifications, data sheets, technical bulletins and other literature/information are minimum standards and guidelines that shall be followed when designing and detailing a project with the QRW1 Drainage EIF System.
- b. Details shall conform to Master Wall Inc.'s details and shall be consistent with the project requirements.
- c. Master Wall Inc. must approve deviations from the standard published details in writing.
- d. The architect, engineer or the designer of the project should determine where the dew point would occur in relationship to the wall assembly and the project location during summer and winter conditions.
- e. Proper fastener spacing shall be strictly adhered to. When fastening to wood or steel framing the fasteners shall be installed 12" (305 mm) vertically and 16" (406 mm) or 24" (610 mm) o.c. horizontally depending on the stud spacing. When fastening to masonry walls fasteners shall be installed 24" (610 mm) vertically and 16" (406 mm) o.c.
- f. At all locations, the reinforced base coat, drainage track or the substrate shall encapsulate the approved insulation board.
- g. The minimum slope of inclined surfaces shall not be less than 1:2 with a maximum length of 12" (305 mm) unless approved in writing by Master Wall Inc. Inclined surfaces which are or could be defined as roofs by the building codes or application are not approved by Master Wall Inc.
- h. The use of dark colors must be considered in relation to wall surface temperature as a function of local climatic conditions.
- i. The insulation board shall be separated from the interior of the building by a 15-minute thermal barrier.
- j. The use and maximum thickness of insulation board shall be in accordance with the applicable building codes.
- k. It is the responsibility of the architect and the purchaser to determine if a product is suitable for their intended use. The architect or designer of the project shall be responsible for all decisions pertaining to the design, details, structural capability, attachment details, shop drawings and the like. Master Wall Inc. has prepared specifications, details and data sheets to assist as guidelines for the use and installation of the products. Master Wall Inc. is not responsible for the design, details, structural capability, attachment details and shop drawings whether it is based on Master Wall Inc.'s information or not.



2. Acceptable weather resistive barriers for the QRW1 Drainage System shall be:
  - a. Code approved weather resistive barrier or a code-recognized equivalent such as Tyvek® StuccoWrap® shall be installed over substrate on all exterior walls before application of system begins in accordance with the manufacturer's recommendations.
  - b. Weather resistive barrier shall be installed horizontally with upper layers overlapping lower layers a minimum of 2" (51 mm). Vertical joints shall overlap a minimum of 6" (152 mm).
  - c. Wrap weather resistive barrier into rough openings at windows, doors, mechanical equipment, and any other openings through the system. Overlap sill flashing tape at jambs at least 2". Reference Master Wall Inc.'s details and technical bulletins for additional information.
  - d. Lap weather resistive barrier over attachment flange of drainage track a minimum of 2".
  
3. Acceptable drainage mat materials for the QRW1 Drainage System shall be:
  - a. Colbond® (Enka®) drainage mats as defined in Master Wall Technical Bulletin #126.
  - b. Benjamin Obdyke® Homeslicker® drainage mat.
  - c. Sill seal material applied at stud lines
  - d. Install drainage mat materials in accordance with manufacturer's details and/or accepted industry practices.
  
4. Substrate
  - a. The maximum deflection under full flexural design loads of the substrate system shall not exceed L/240.
  - b. Acceptable substrates for the QRW1 Drainage EIF System include painted or unpainted brick, unit masonry, concrete, stucco brown coat, exterior grade gypsum sheathing, and approved cementitious and exterior wood sheathings.
  - c. Substrates not approved in the manufacturer's published literature shall be approved by the manufacture in writing prior to the application of the system.
  - d. The project architect or engineer shall engineer the substrate with regard to the required structural performance.
  
5. Expansion Joints
  - a. Expansion joints shall be installed in the EIFS a maximum of every 30 lineal feet (9 m). Reference construction documents for specific locations.
  - b. Expansion joints in the system are required at building expansion joints, at prefabricated panel joints, where substrates change, at floor lines in wood framed construction, and where structural movement is anticipated.
  
6. Sealants
  - a. Sealants and backer rod, as required at expansion joints and dissimilar substrates, shall provide a complete watertight system.
  - b. The sealants in an EIFS expansion joint, or any sealant joint that anticipates significant movement, shall be bonded to the reinforced base coat, not the finish coat. The color of the mesh shall not be visible and the texture of the mesh shall not be exposed within base coat at these locations.



Section 07 24 19

Corporate • P.O. Box 397 • Fortson • Georgia • 31808 • 800-755-0825 • FAX 706-569-6704

Technical • 800-760-2861 • FAX 734-433-0930

7. Flashings
  - a. Roof
    - 1) Crickets and step flashing shall be properly installed around chimneys.
    - 2) Flashing shall be installed at rooflines in a manner to prevent any intrusion of water behind the weather barrier. This shall include the use of roof kick-out flashing at roof terminations.
  - b. Openings
    - 1) Heads, jambs, and sills of all rough openings must be wrapped with the weather resistive barrier prior to installation of windows, doors, or mechanical equipment.
    - 2) Local building codes may require use of self-sealing flashing tape on the sills.
    - 3) Drainage track and metal flashing shall be installed at heads of openings.
    - 4) Continuous metal flashing shall be installed at heads of ganged windows.
  - c. Decks
    - 1) The system must be terminated at least 2" (51 mm) above poured decks, patios, sidewalks, etc.
    - 2) Wooden decks must be flashed before system is installed.
8. Penetrations
  - a. All penetrations through the system such as hose bibs, dryer vents, lighting fixtures, air-conditioning hoses, etc. must be properly sealed to insure the integrity of the system.

B. Qualifications

1. The EIFS Manufacturer shall have manufactured Exterior Insulation and Finish Systems in the United States for at least 10 years.
2. The Applicator shall be knowledgeable in the proper installation of the Master Wall Inc. QRW1 Drainage EIF System.
3. The Applicator shall have demonstrated the ability to install the system on projects of similar size and complexity.
4. The Applicator shall provide the proper equipment, manpower and supervision on the job site to install the system in compliance with project plans and specifications.
5. The Insulation Board Manufacturer shall be approved by Master Wall Inc. to produce Polyisocyanurate Insulation Board for the QRW1 Drainage EIF System in accordance with Master Wall Inc.'s specifications and details.
6. The sealant contractor shall be experienced in the installation of high performance industrial and commercial sealants.
7. Prior to the installation of the QRW1 Drainage EIF System, erect sample wall mock-up using materials and joint details required for final work. Provide special features as directed for sealant and contiguous work. Build mock-up at the site where directed of full thickness, indicating the proposed color, texture, and workmanship to be expected in the completed work. Obtain architect's acceptance of the mock-up in regard to aesthetic quality before start of work. Retain mock-up during construction as a standard for judging completed work. Do not alter, move, or destroy mock-up until work is completed, and until final acceptance of the project by architect.



#### 1.05 SUBMITTALS

- A. The Applicator shall submit a list of completed projects of like size and complexity.
- B. The Applicator shall submit a certificate of training indicating that they have been given instructions on the proper installation of the EIF System.
- C. The Applicator shall submit EIFS Manufacturer's current literature, brochures, specifications, and details.
- D. The Applicator shall submit sufficient samples of each finish texture and color selected. The samples shall be prepared with the same tools and techniques required for the actual project. Color and texture should be approved based on the job site mock-up samples.
- E. The Applicator shall provide any shop drawings that may be applicable to the project for approval by the project architect.

#### 1.06 DELIVERY, STORAGE AND HANDLING

- A. Deliver all materials in original unopened packages with labels intact. Verify all quantities, colors, and textures against bill of lading.
- B. Store all materials protected from direct exposure to weather conditions and at temperatures not less than 40° F (5° C) or greater than 110° F (43° C).
- C. Stack insulation board flat, fully supported off the ground and protected from direct exposure to the sun.
- D. Material safety data sheets (MSDS) shall be supplied for the components of the EIFS and be available at the job site.

#### 1.07 JOB CONDITIONS

- A. Ambient air temperatures shall be 40° F (5° C) or greater and rising at the time of installation of the Master Wall Inc. products and shall remain at 40° F (5° C) or greater for at least 24 hours after application.
- B. Provide supplemental heat and protection as required when the temperature and conditions are not in accordance with installation requirements. Sufficient ventilation and time shall be provided to ensure that materials have sufficiently dried prior to removing supplemental heat.
- C. Adequate protection shall be provided to prevent weather conditions (humidity, temperature, and precipitation) from having an affect on the curing or drying time of Master Wall Inc. materials.
- D. Adjacent materials and the QRW1 Drainage EIF System shall be protected during installation and while curing from weather and shall be protected from site damage.
- E. Coordinate installation of the QRW1 Drainage EIF System with related work specified in other sections to ensure that the wall assembly is protected to prevent water from getting behind the system. The cap flashing shall be installed as soon as possible after the finish coat has been applied. When this is not possible, temporary protection shall be provided immediately in this area.
- F. All sealants shall be installed in a timely manner. Protect open joints from water intrusion during construction with backer rod, or temporary covering, until permanently sealed.
- G. Sufficient manpower and equipment shall be employed to ensure a continuous operation, free of cold joints, scaffolding lines, texture variations, etc.



## 1.08 REPAIR AND MAINTENANCE

- A. Refer to Master Wall Inc. specific repair and maintenance procedures.
- B. Sealants and flashings shall be inspected annually to verify that the products are not allowing water intrusion behind the weather barrier. If sealant and/or flashings are allowing water intrusion behind the weather barrier, repairs should be made immediately.

## 1.09 LIMITED MATERIALS WARRANTY

- A. A Limited Materials Warranty shall be issued upon the receipt of a properly completed warranty request form.

## PART 2 PRODUCTS

### 2.01 MANUFACTURER

A. All components of the QRW1 Drainage System shall be supplied or obtained from Master Wall Inc. or its authorized distributors. Substitutions or additions of materials other than specified will void the warranty.

### 2.02 MATERIALS

- A. Portland Cement: Shall be Type I or II, meeting ASTM C 150, white or gray in color, fresh and free of lumps.
- B. Water: Shall be potable, clean and free of foreign matter.
- C. Mechanical Fasteners for mechanically attached systems: Shall be Wind-lock's Wind Devil™ plates, or Master Wall Inc. approved equivalent, used in conjunction with corrosion resistant fasteners appropriate for the substrate system.
- D. Metal Flashing Components: Complying with SMACNA Recommendations. Reference Section 07620.
- E. Sealant Systems: Reference Sealant Specification, Section 07900.
- F. Window & Door Systems: Detailed by the designer and suitable for EIFS. Reference Section 08000.

### 2.03 COMPONENTS

#### A. Starter Tracks/Drainage Tracks

Vinyl Corp. PB Starter Strip/Casing Bead product # CBS 150-16W or Plastic Components Starter Trac® product # STWP-15 shall be used in accordance with Master Wall Inc. details.

Alternate termination methods may be used in accordance with Master Wall Inc. details.

#### B. Insulation Board

##### A. Polyisocyanurate Insulation Board

- 1. Thermax Quik-R as manufactured by Celotex/Dow Building Products Division, Stucco-Shield II as manufactured by Atlas Energy Products Division or an approved equal insulation board shall be used with the QRW1 Drainage EIF System. Minimum 1" (25 mm) thickness is required.



**B. Mechanical Fasteners and Plastic Washers**

The Celotex Galvanized Quik-Cap Washer, Wind-lock ULP-402 Plate or an approved equal shall be used when fastening is required. The appropriate fastener shall be used to meet the requirements of the specific project, local building code and the anticipated wind loads.

**D. Reinforcing Mesh**

Open weave glass fiber fabric, treated for alkaline resistance and compatibility with Master Wall Base Coats, and conforming ASTM D-76, D-579, D-5035, MIL-Y-1140 and meeting a minimum Medium Impact Resistance (50-89 in-lbs) when tested to EIMA 101.86 Impact Resistance Standards.

1. Detail Mesh
2. Standard Mesh
3. Hi-Tech Mesh
4. Medium Mesh
5. Strong Mesh
6. Ultra Mesh

**E. Base Coats**

1. Master Wall Inc. Foam & Mesh (F&M) Adhesive: An acrylic-based product mixed one-to-one by weight with Portland cement designed for use with reinforcing mesh as the base coating over the insulation board.
2. Master Wall Bagged Base Coat (MBB): A polymer based cementitious product mixed with 5 to 6 quarts of water for use as an adhesive and base coating over the insulation board.
3. F&M Plus: An acrylic-based high build product mixed one-to-one by weight with Portland cement designed for use with reinforcing mesh as the base coating over the insulation board. (This product shall be used where indicated on the construction drawings when a leveling base coat is required.)

**F. Water Resistant Adhesive & Base Coat**

1. Guardian – An acrylic-based product mixed one-to-one by weight with Portland cement for use as the adhesive to bond insulation board to an approved substrate and/or as a base coat with reinforcing mesh over insulation board. (This product should be used as designated on the construction drawings where additional resistance to moisture is needed.)



G. Superior Finish: Master Wall Inc.'s Superior Finishes are acrylic-based wall coatings available in a variety of colors and textures. The following textures are available:

1. Perfect - riled texture
2. Spray – sand type texture
3. R-Coarse – coarse riled texture
4. Desert Sand – coarse sand texture
5. Refinish – Fine texture used to create numerous finishes
6. Superior Stone/Aggrestone Specialty Finishes

Note: The above textures excluding Superior Stone and Aggrestone Finishes are also available in the Superior Silicone Coat product line and the Superior Elastomeric Coat product line. Superior Silicone Coat combines acrylic and the siloxane polymers to provide the maximum resistance to moisture. Superior Elastomeric Coat utilizes elastomeric polymers to enable the finishes to bridge minor cracking.

H. Water: Shall be clear, clean and potable without any foreign matter in the solution, which may affect the color and setting qualities of the cement, adhesive, base or finish coat.

I. Cement: Type I or I-II Portland cement meeting ASTM C-150.

J. Sealants Systems (waterproofing trades): Reference sealant specification (Section 07920) and Master Wall sealant recommendations (Technical Bulletin MW-131-050101) for acceptable sealants.

## **PART 3 EXECUTION**

### **3.01 EXAMINATION**

A. Prior to installation of the QRW1 Drainage System, the contractor shall verify that the substrate and water barrier:

1. Is of a type listed in Section 1.04.C.1.
2. Is installed to shed water in accordance with Section 1.04.C.2.
3. Is flat within 6.4 mm (1/4 in) in a 1.2 m (4 ft) radius.
4. Is sound, dry, connections are tight, has no surface voids, projections or other conditions that may interfere with the QRW1 Drainage System installation or performance.

B. Prior to the installation of the QRW1 Drainage System, the architect or general contractor shall insure that all needed flashings and other waterproofing details have been completed, if such completion is required prior to the QRW1 Drainage application. Additionally, the Contractor shall ensure that:

1. Metal roof flashing has been installed in accordance with Asphalt Roofing Manufacturers Association (ARMA) Standards.
2. Openings are flashed in accordance with the QRW1 Drainage System Installation Details or as otherwise necessary to prevent water penetration.
3. Chimneys, Balconies, and Decks have been properly flashed.
4. Windows, Doors, etc. are installed and flashed per manufacturer's requirements and the QRW1 Drainage System Installation Details.



C. Prior to the installation of the QRW1 Drainage System, the contractor shall notify the general contractor, and/or architect, and/or owner of all discrepancies.

### 3.02 PREPARATION

- A. The QRW1 Drainage materials shall be protected by permanent or temporary means from inclement weather and other sources of damage prior to, during, and following application until completely dry.
- B. Protect adjoining work and property during QRW1 Drainage installation.
- C. The substrate shall be prepared as to be free of foreign materials, such as, oil, dust, dirt, form release agents, efflorescence, paint, wax, water repellants, moisture, frost and any other condition that inhibit adhesion.

### 3.03 INSTALLATION

- A. The system shall be installed in accordance with the current Master Wall Inc. QRW1 Drainage System Application Instructions.
- B. The overall minimum base coat thickness shall be sufficient to fully embed the mesh.
- C. Sealant shall not be applied directly to textured finishes.
- D. When installing the QRW1 Drainage System, mechanically attach according to Master Wall Inc. and local requirements.
- E. High impact meshes shall be installed as specified at ground level, high traffic areas and other areas exposed to or susceptible to impact damage.

### 3.04 FIELD QUALITY CONTROL

- A. The contractor shall be responsible for the proper application of the QRW1 Drainage materials.
- B. Master Wall Inc. assumes no responsibility for on-site inspections or application of its products.
- C. If required, the contractor shall certify in writing the quality of work performed relative to the substrate system, details, installation procedures, workmanship and as to the specific products used.
- D. If required, the EPS supplier shall certify in writing that the EPS meets Master Wall Inc.'s specifications.
- E. If required, the sealant contractor shall certify in writing that the sealant application is in accordance with the sealant manufacturer's and Master Wall Inc.'s recommendations.

### 3.05 CLEANING

- A. All excess QRW1 Drainage System materials shall be removed from the job site by the contractor in accordance with contract provisions and as required by applicable law.
- B. All surrounding areas, where the QRW1 Drainage System has been installed, shall be left free of debris and foreign substances resulting from the contractor's work.



### 3.06 PROTECTION

A. The QRW1 Drainage System shall be protected from inclement weather and other sources of damage until dry and permanent protection in the form of flashings, sealants, etc. are installed.

#### Disclaimer

This Specification is published for general informational purposes only and is not intended to imply that these are the only materials, procedures, or methods, which are available or suitable. Materials, procedures, or methods may vary according to the particular circumstances, local building code requirements, design conditions, or statutory and regulatory requirements. While the information in this specification is believed to be accurate and reliable, it is presented without guarantee or responsibility on the part of Master Wall Inc.



## QRW1 Drainage EIFS

Conceptual Details

Corporate • P.O. Box 397 • Fortson • Georgia • 31808 • 800-755-0825 • FAX 706-569-6704

Technical • 800-760-2861 • FAX 734-433-0930

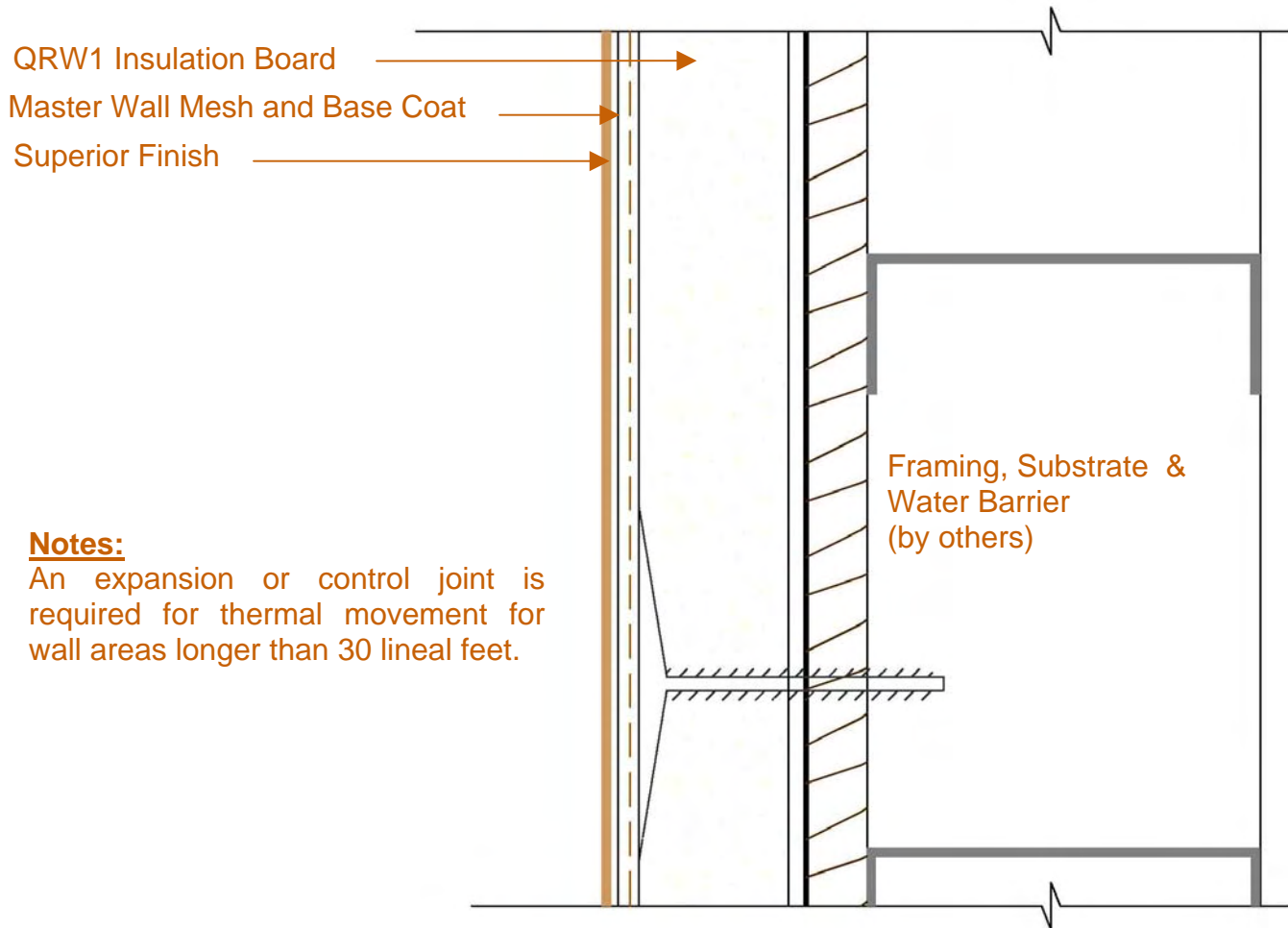

**Notes:**

An expansion or control joint is required for thermal movement for wall areas longer than 30 lineal feet.

## QR-01 Cross-Section

These drawings relay the conceptual conditions of Master Wall Systems and are not the construction drawings. Ultimately the design and detailing of an entire wall system is the responsibility of a professional. These details will guide the design professional in the use of Master Wall Products. Master Wall disclaims design, warranty or construction intent or responsibility.



# QRW1 Drainage EIFS

## Conceptual Details

Corporate • P.O. Box 397 • Fortson • Georgia • 31808 • 800-755-0825 • FAX 706-569-6704

Technical • 800-760-2861 • FAX 734-433-0930

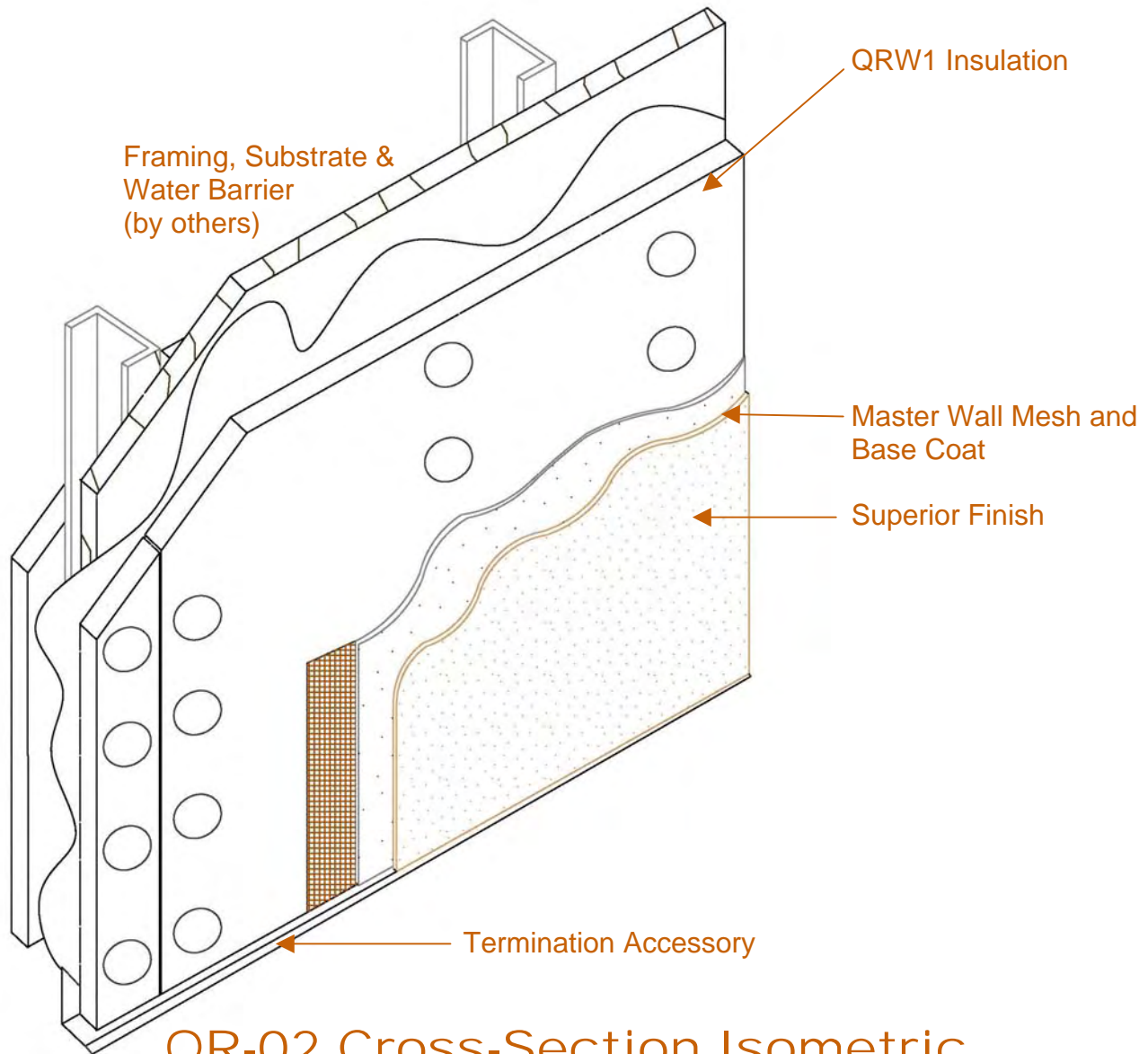

These drawings relay the conceptual conditions of Master Wall Systems and are not the construction drawings. Ultimately the design and detailing of an entire wall system is the responsibility of a professional. These details will guide the design professional in the use of Master Wall Products. Master Wall disclaims design, warranty or construction intent or responsibility.



## QRW1 Drainage EIFS

Conceptual Details

Corporate • P.O. Box 397 • Fortson • Georgia • 31808 • 800-755-0825 • FAX 706-569-6704

Technical • 800-760-2861 • FAX 734-433-0930

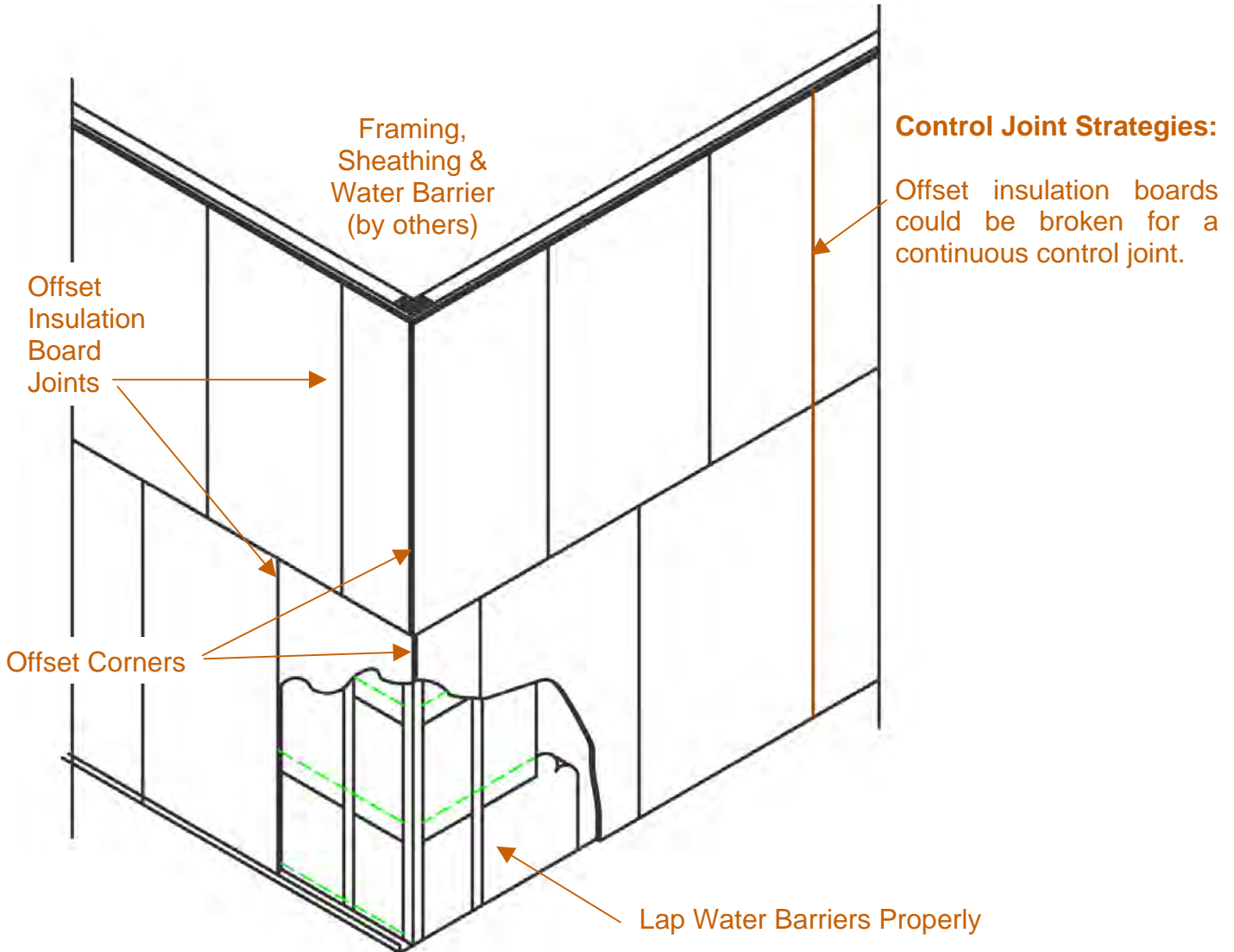

## QR-03 Insulation Board Layout

These drawings relay the conceptual conditions of Master Wall Systems and are not the construction drawings. Ultimately the design and detailing of an entire wall system is the responsibility of a professional. These details will guide the design professional in the use of Master Wall Products. Master Wall disclaims design, warranty or construction intent or responsibility.



# QRW1 Drainage EIFS

## Conceptual Details

Corporate • P.O. Box 397 • Fortson • Georgia • 31808 • 800-755-0825 • FAX 706-569-6704

Technical • 800-760-2861 • FAX 734-433-0930

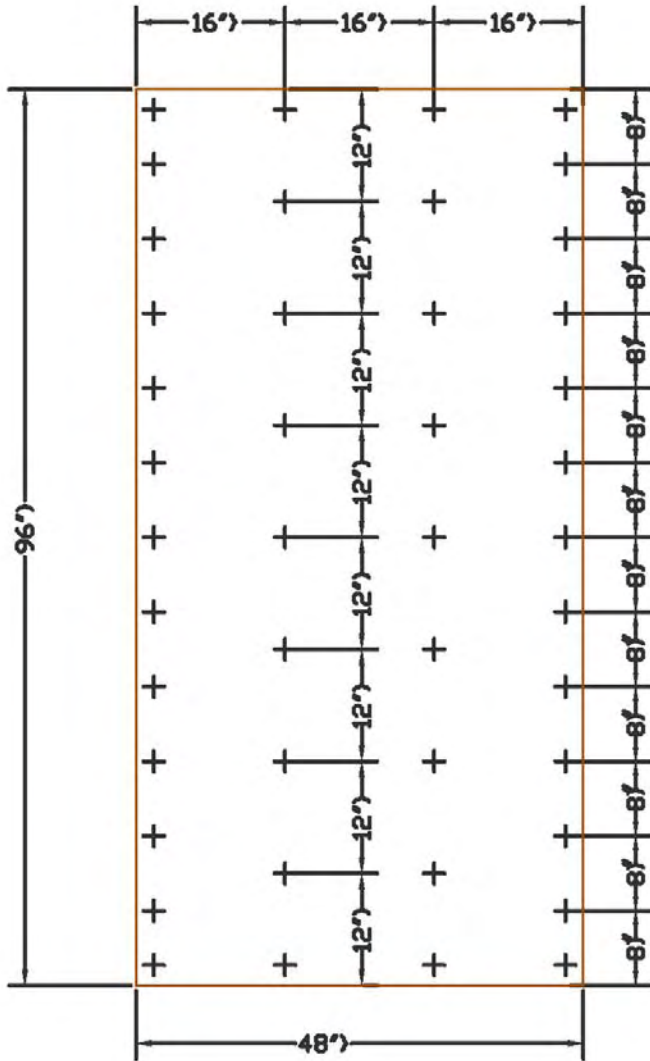

**Wood Substrates**

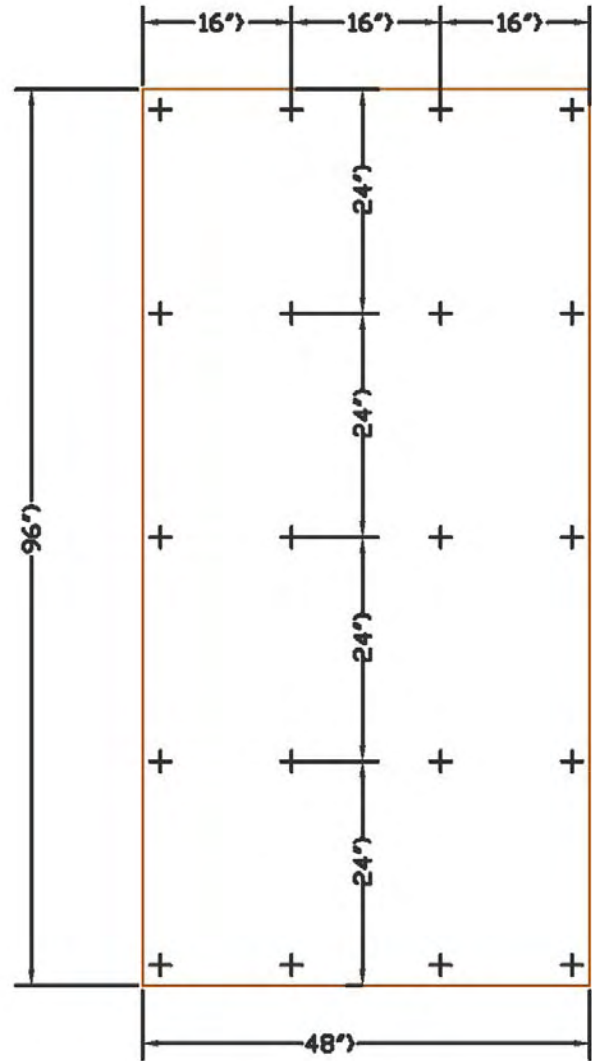

**Masonry Substrates**

## QR-04 Insulation Board Fastening

These drawings relay the conceptual conditions of Master Wall Systems and are not the construction drawings. Ultimately the design and detailing of an entire wall system is the responsibility of a professional. These details will guide the design professional in the use of Master Wall Products. Master Wall disclaims design, warranty or construction intent or responsibility.



## QRW1 Drainage EIFS

### Conceptual Details

Corporate • P.O. Box 397 • Fortson • Georgia • 31808 • 800-755-0825 • FAX 706-569-6704

Technical • 800-760-2861 • FAX 734-433-0930

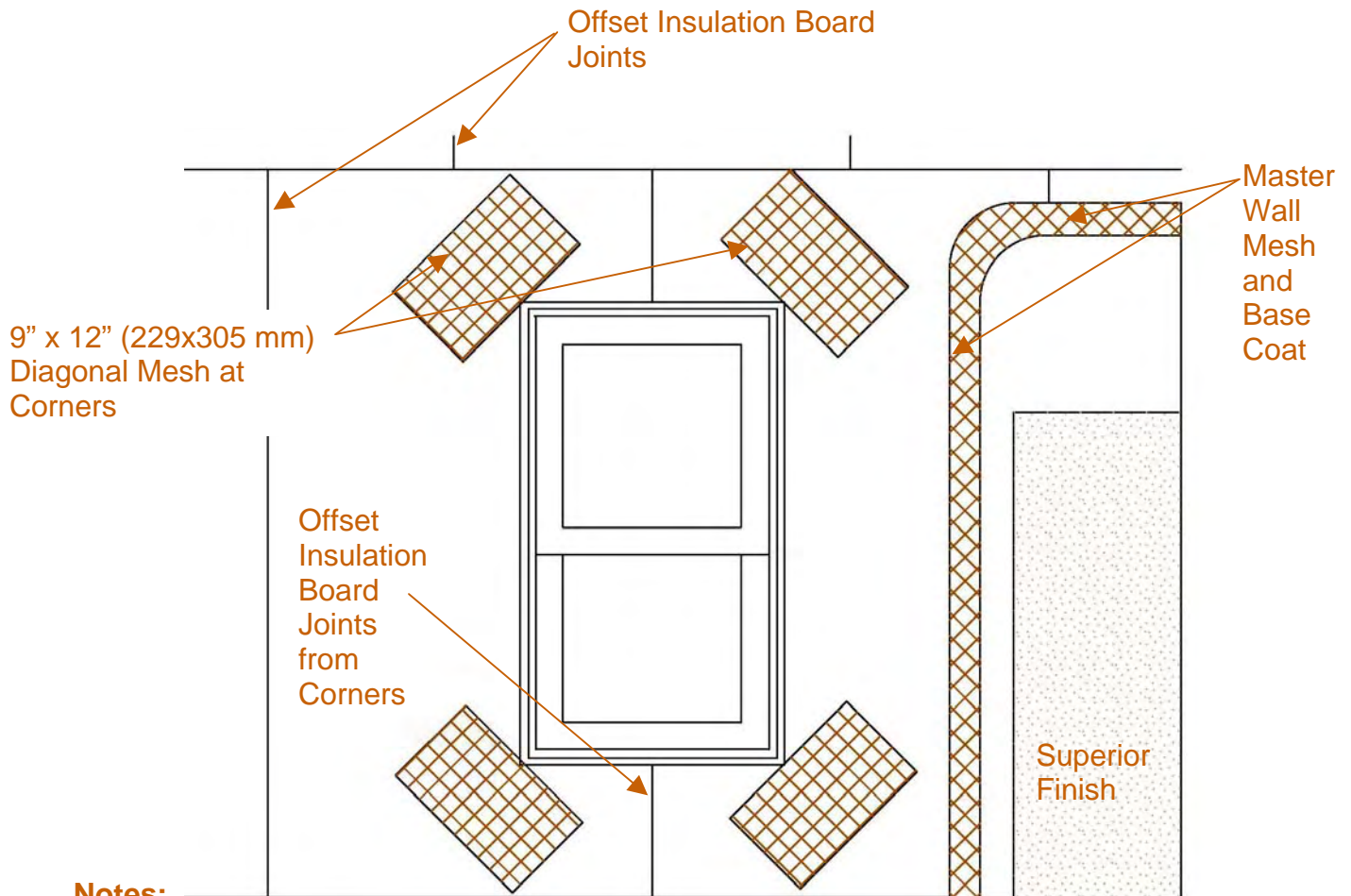

#### Notes:

- Typical detailing for windows, doors and other openings
- Designer to size sealant joint for anticipated movement, minimum 1/2" (13 mm) sealant joint by sealant contractor
- Flashing may be required by others

## QR-05 Typical Reinforcing Mesh Application

These drawings relay the conceptual conditions of Master Wall Systems and are not the construction drawings. Ultimately the design and detailing of an entire wall system is the responsibility of a professional. These details will guide the design professional in the use of Master Wall Products. Master Wall disclaims design, warranty or construction intent or responsibility.



# QRW1 Drainage EIFS

## Conceptual Details

Corporate • P.O. Box 397 • Fortson • Georgia • 31808 • 800-755-0825 • FAX 706-569-6704

Technical • 800-760-2861 • FAX 734-433-0930

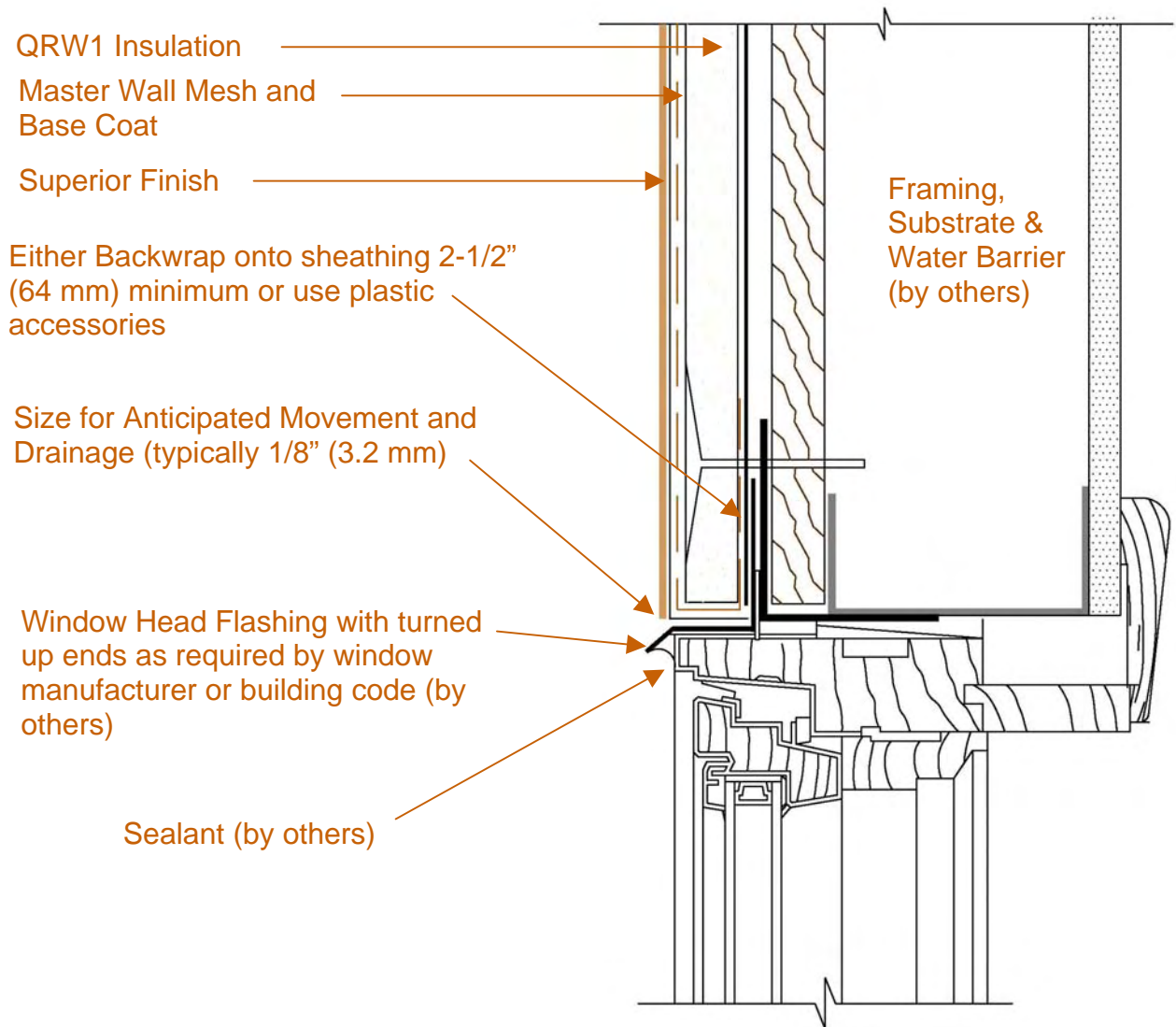

## QR-06 Window Head

These drawings relay the conceptual conditions of Master Wall Systems and are not the construction drawings. Ultimately the design and detailing of an entire wall system is the responsibility of a professional. These details will guide the design professional in the use of Master Wall Products. Master Wall disclaims design, warranty or construction intent or responsibility.



# QRW1 Drainage EIFS

## Conceptual Details

Corporate • P.O. Box 397 • Fortson • Georgia • 31808 • 800-755-0825 • FAX 706-569-6704

Technical • 800-760-2861 • FAX 734-433-0930

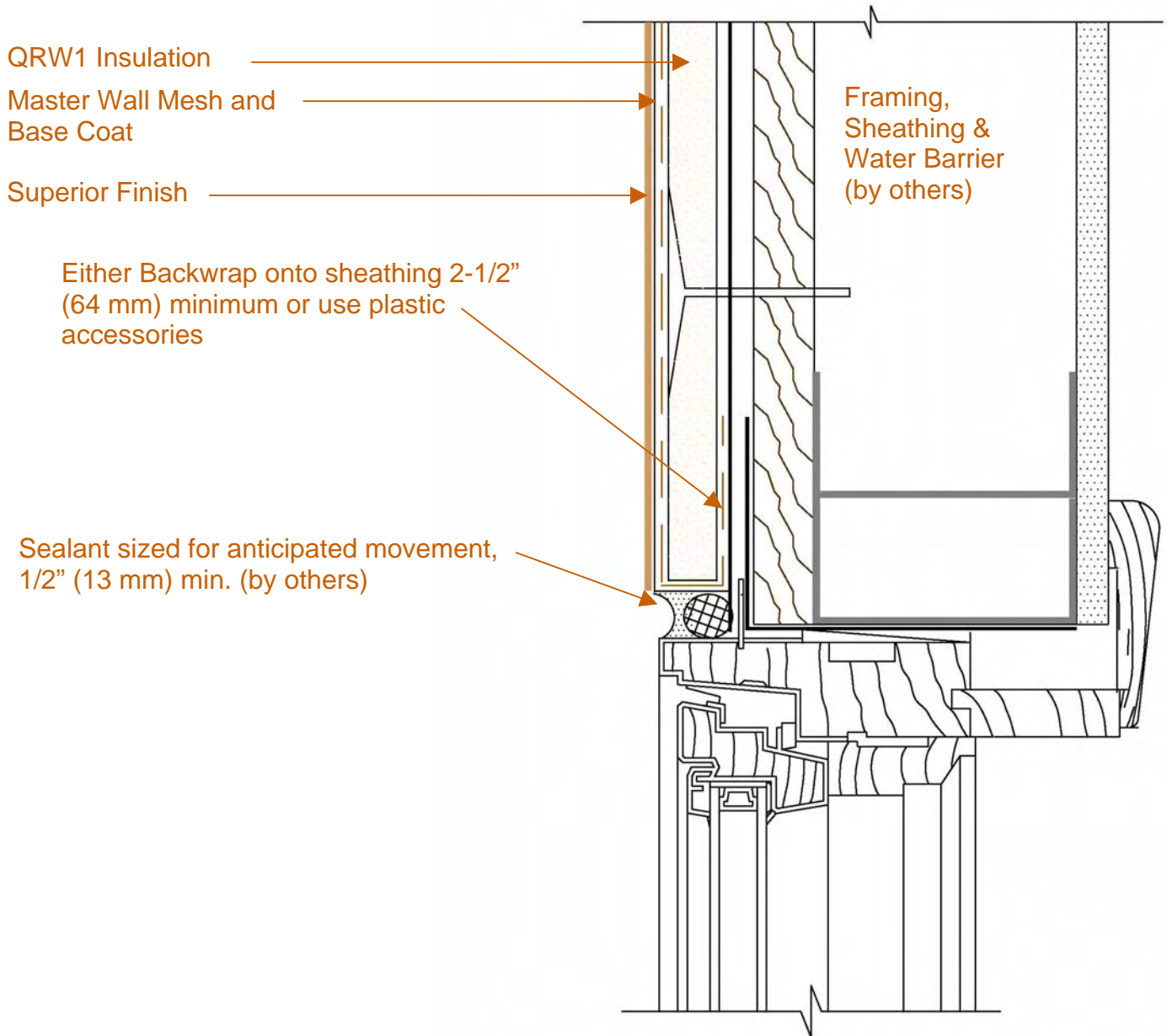

## QR-07 Window Jamb Detail

These drawings relay the conceptual conditions of Master Wall Systems and are not the construction drawings. Ultimately the design and detailing of an entire wall system is the responsibility of a professional. These details will guide the design professional in the use of Master Wall Products. Master Wall disclaims design, warranty or construction intent or responsibility.



# QRW1 Drainage EIFS

Conceptual Details

Corporate • P.O. Box 397 • Fortson • Georgia • 31808 • 800-755-0825 • FAX 706-569-6704

Technical • 800-760-2861 • FAX 734-433-0930

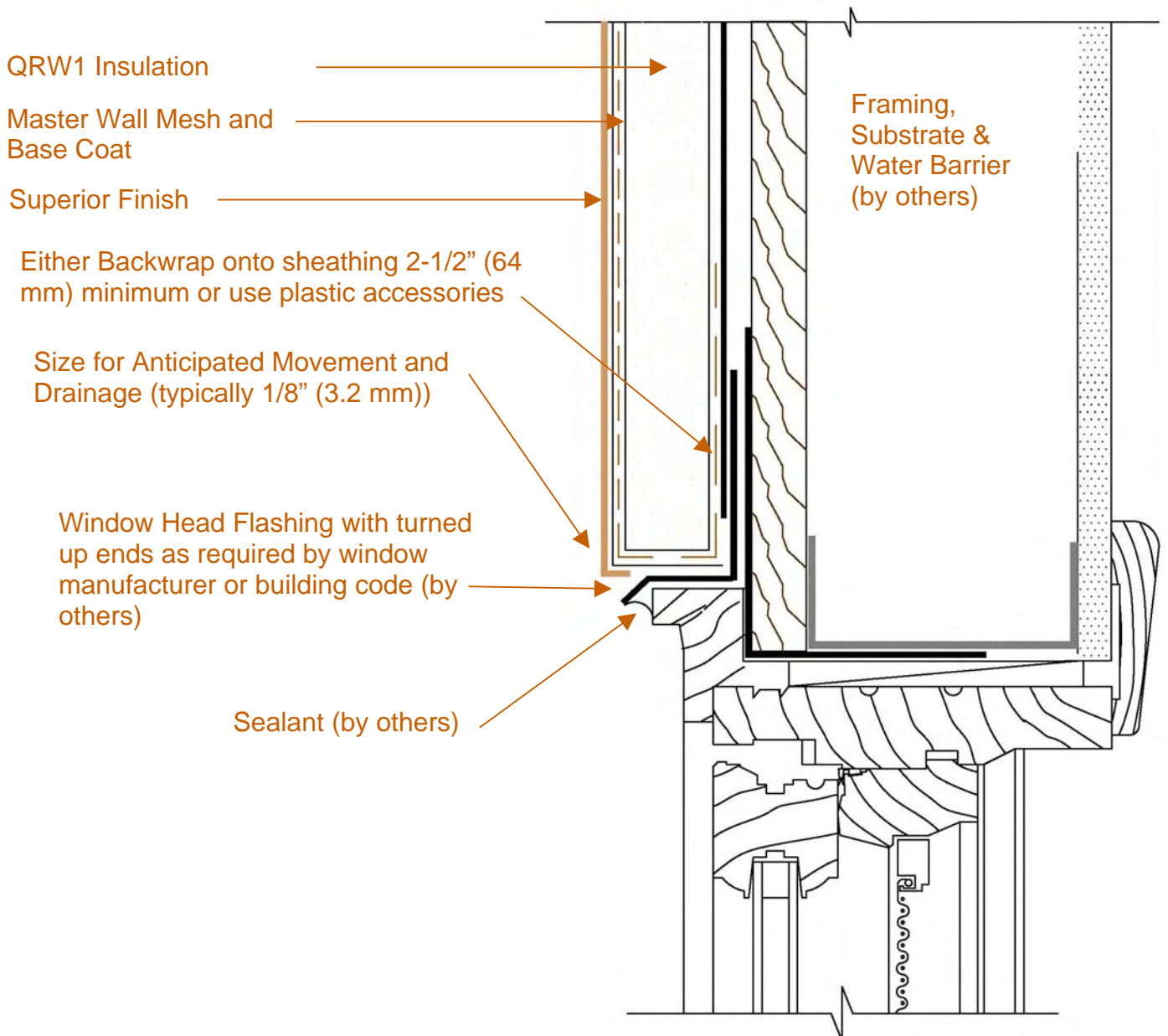

## QR-08 Wood Window Head Detail

These drawings relay the conceptual conditions of Master Wall Systems and are not the construction drawings. Ultimately the design and detailing of an entire wall system is the responsibility of a professional. These details will guide the design professional in the use of Master Wall Products. Master Wall disclaims design, warranty or construction intent or responsibility.



## QRW1 Drainage EIFS

### Conceptual Details

Corporate • P.O. Box 397 • Fortson • Georgia • 31808 • 800-755-0825 • FAX 706-569-6704

Technical • 800-760-2861 • FAX 734-433-0930

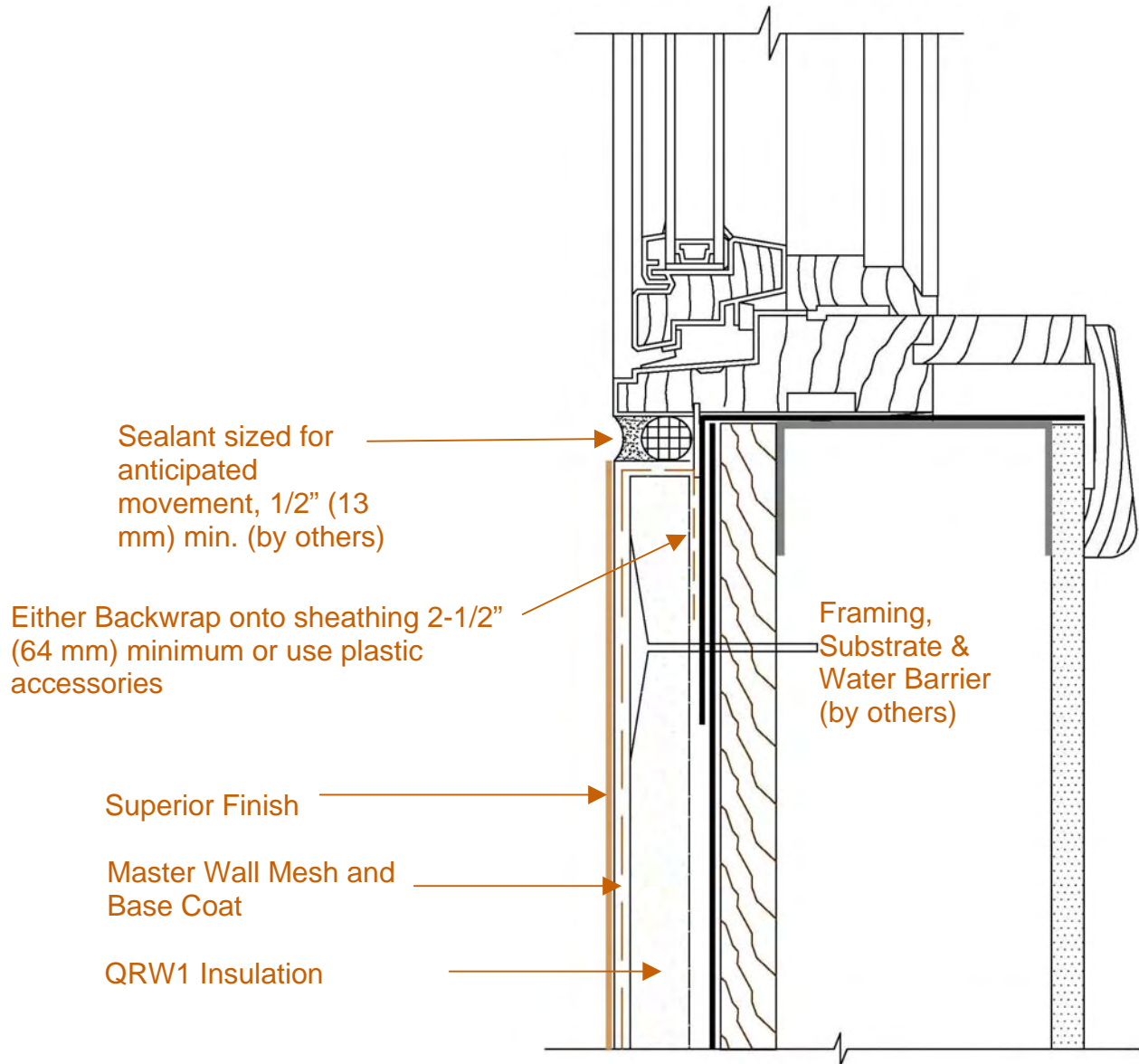

## QR-09 Window Sill Detail

These drawings relay the conceptual conditions of Master Wall Systems and are not the construction drawings. Ultimately the design and detailing of an entire wall system is the responsibility of a professional. These details will guide the design professional in the use of Master Wall Products. Master Wall disclaims design, warranty or construction intent or responsibility.



## QRW1 Drainage EIFS

Conceptual Details

Corporate • P.O. Box 397 • Fortson • Georgia • 31808 • 800-755-0825 • FAX 706-569-6704

Technical • 800-760-2861 • FAX 734-433-0930

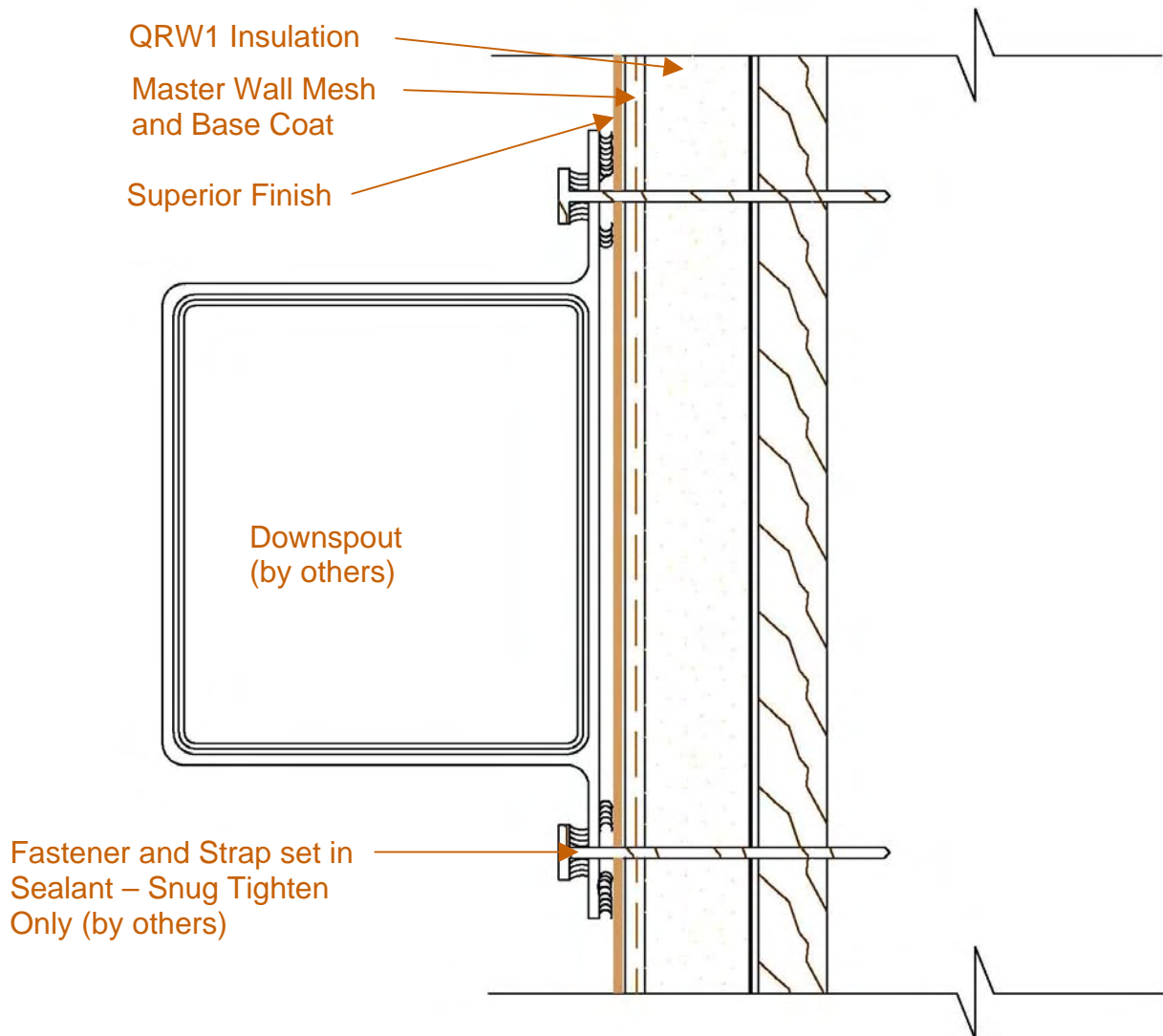

## QR-10 Typical Downspout Attachment

These drawings relay the conceptual conditions of Master Wall Systems and are not the construction drawings. Ultimately the design and detailing of an entire wall system is the responsibility of a professional. These details will guide the design professional in the use of Master Wall Products. Master Wall disclaims design, warranty or construction intent or responsibility.



## QRW1 Drainage EIFS

Conceptual Details

Corporate • P.O. Box 397 • Fortson • Georgia • 31808 • 800-755-0825 • FAX 706-569-6704

Technical • 800-760-2861 • FAX 734-433-0930

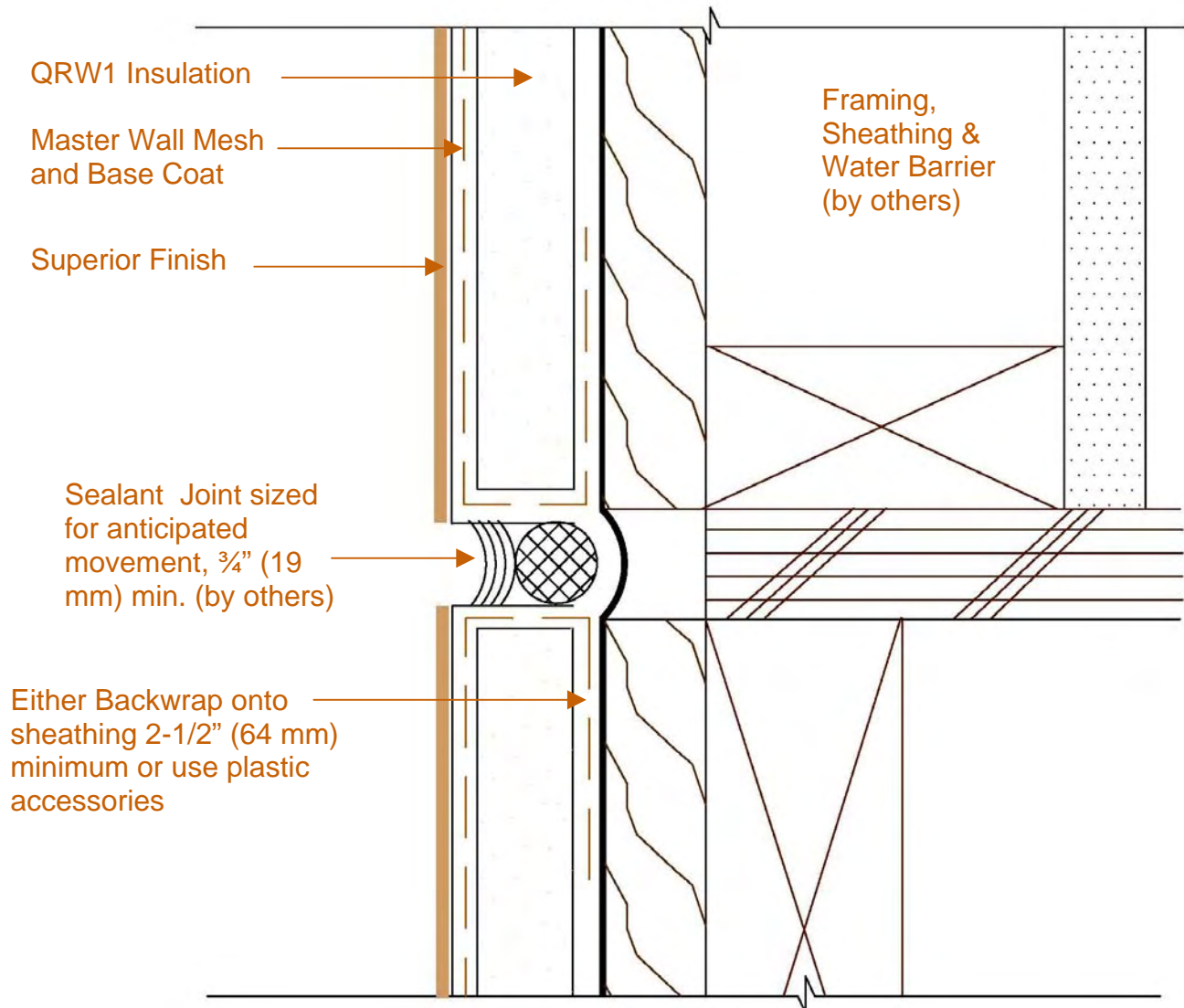

### QR-11 Typical Horizontal Expansion Joint at Floor Line – Wood Frame Construction

These drawings relay the conceptual conditions of Master Wall Systems and are not the construction drawings. Ultimately the design and detailing of an entire wall system is the responsibility of a professional. These details will guide the design professional in the use of Master Wall Products. Master Wall disclaims design, warranty or construction intent or responsibility.



## QRW1 Drainage EIFS

Conceptual Details

Corporate • P.O. Box 397 • Fortson • Georgia • 31808 • 800-755-0825 • FAX 706-569-6704

Technical • 800-760-2861 • FAX 734-433-0930

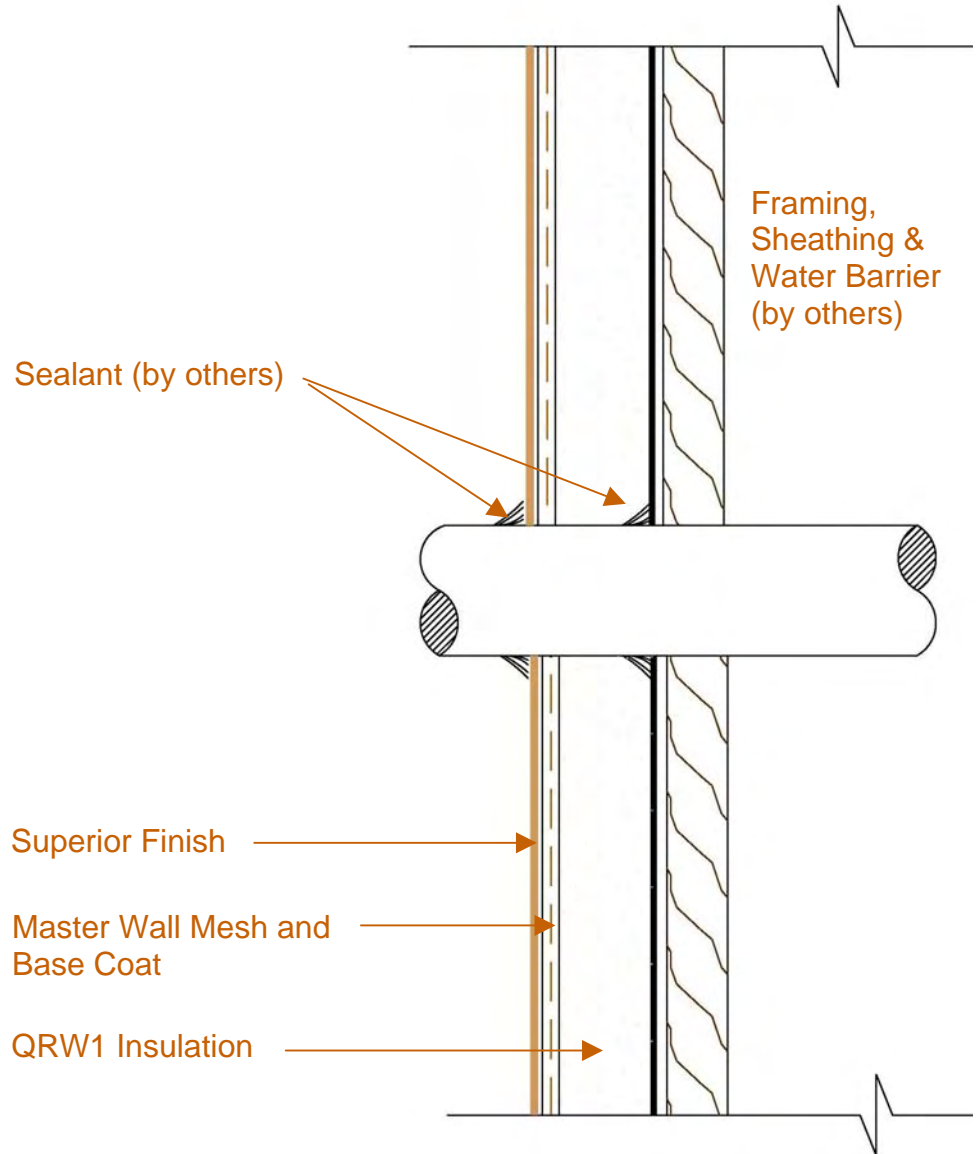

## QR-12 Pipe Penetration Detail

These drawings relay the conceptual conditions of Master Wall Systems and are not the construction drawings. Ultimately the design and detailing of an entire wall system is the responsibility of a professional. These details will guide the design professional in the use of Master Wall Products. Master Wall disclaims design, warranty or construction intent or responsibility.



# QRW1 Drainage EIFS

Conceptual Details

Corporate • P.O. Box 397 • Fortson • Georgia • 31808 • 800-755-0825 • FAX 706-569-6704

Technical • 800-760-2861 • FAX 734-433-0930

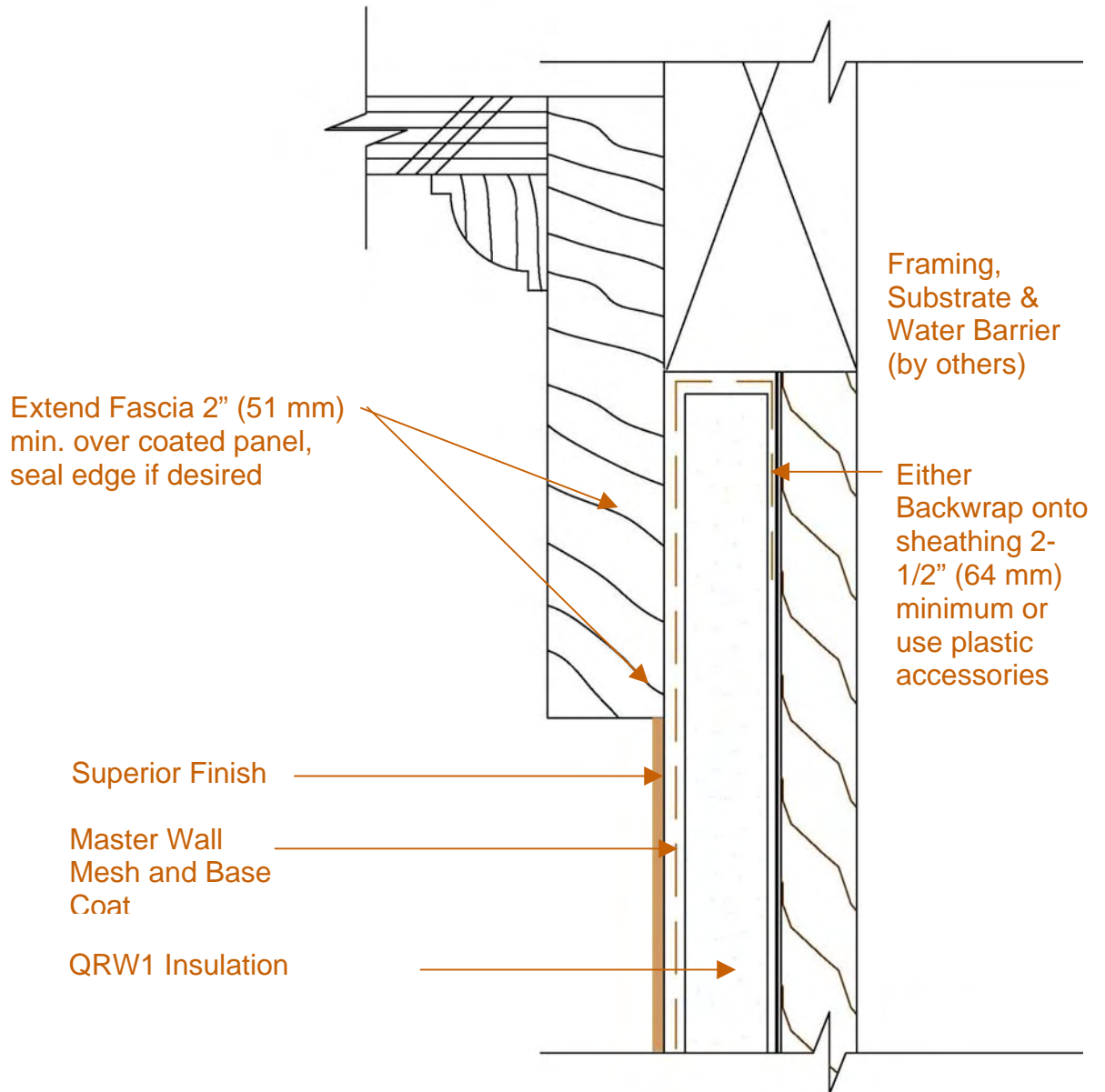

## QR-13 Soffit/Gable Termination

These drawings relay the conceptual conditions of Master Wall Systems and are not the construction drawings. Ultimately the design and detailing of an entire wall system is the responsibility of a professional. These details will guide the design professional in the use of Master Wall Products. Master Wall disclaims design, warranty or construction intent or responsibility.



# QRW1 Drainage EIFS

## Conceptual Details

Corporate • P.O. Box 397 • Fortson • Georgia • 31808 • 800-755-0825 • FAX 706-569-6704

Technical • 800-760-2861 • FAX 734-433-0930

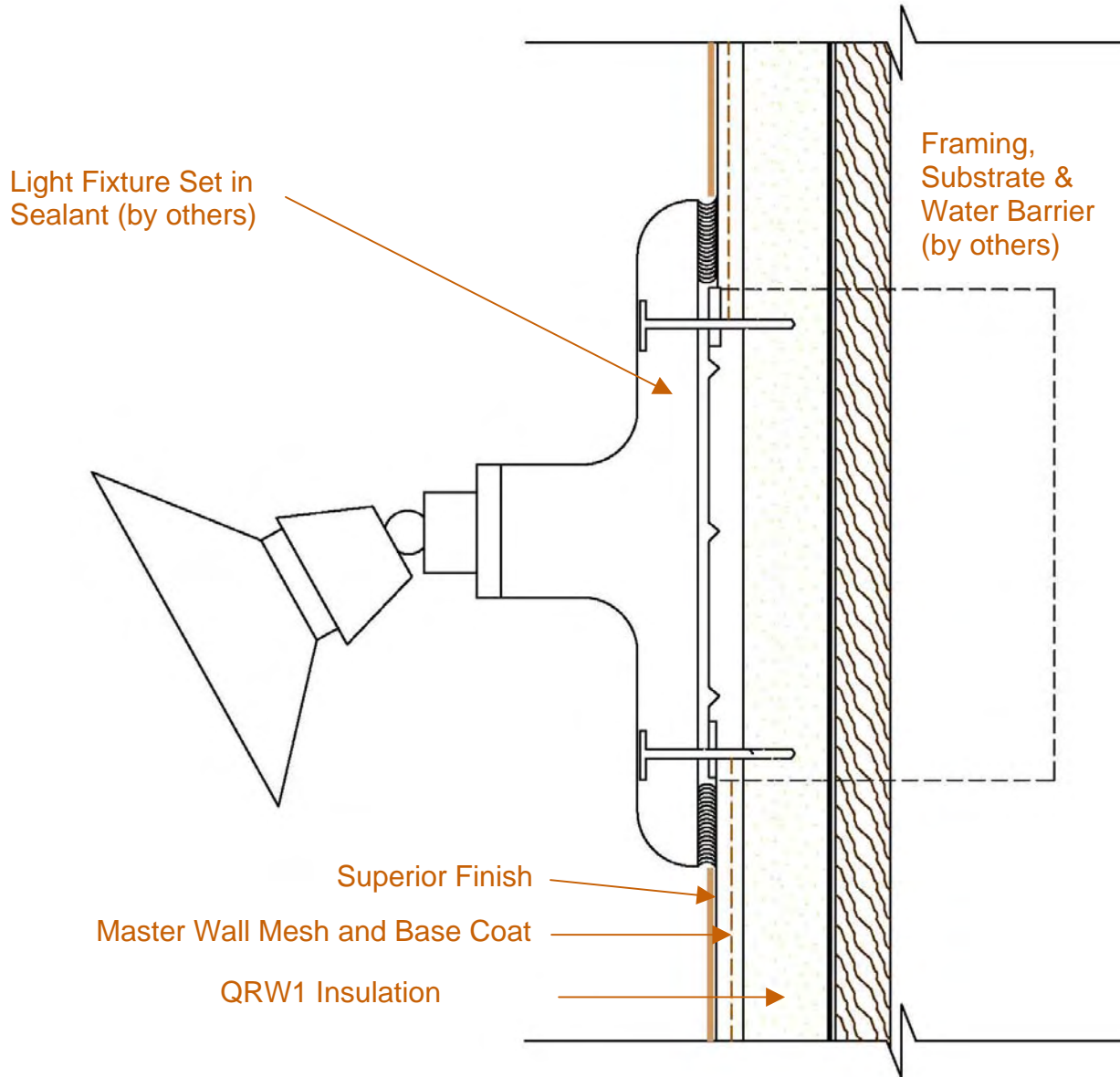

## QR-14 Typical Light Fixture

These drawings relay the conceptual conditions of Master Wall Systems and are not the construction drawings. Ultimately the design and detailing of an entire wall system is the responsibility of a professional. These details will guide the design professional in the use of Master Wall Products. Master Wall disclaims design, warranty or construction intent or responsibility.



## QRW1 Drainage EIFS

### Conceptual Details

Corporate • P.O. Box 397 • Fortson • Georgia • 31808 • 800-755-0825 • FAX 706-569-6704

Technical • 800-760-2861 • FAX 734-433-0930

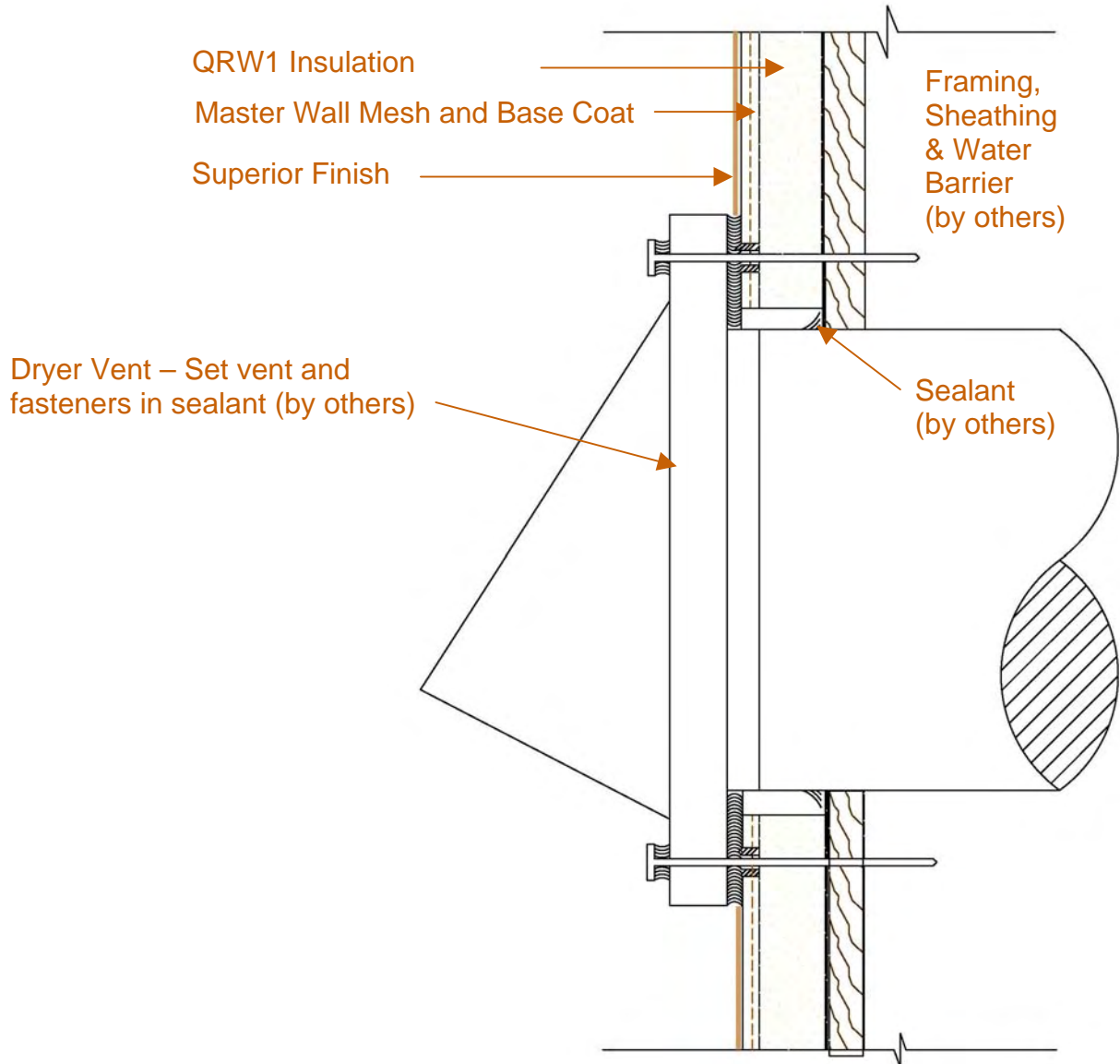

## QR-15 Dryer Vent Detail

These drawings relay the conceptual conditions of Master Wall Systems and are not the construction drawings. Ultimately the design and detailing of an entire wall system is the responsibility of a professional. These details will guide the design professional in the use of Master Wall Products. Master Wall disclaims design, warranty or construction intent or responsibility.



## QRW1 Drainage EIFS

Conceptual Details

Corporate • P.O. Box 397 • Fortson • Georgia • 31808 • 800-755-0825 • FAX 706-569-6704

Technical • 800-760-2861 • FAX 734-433-0930

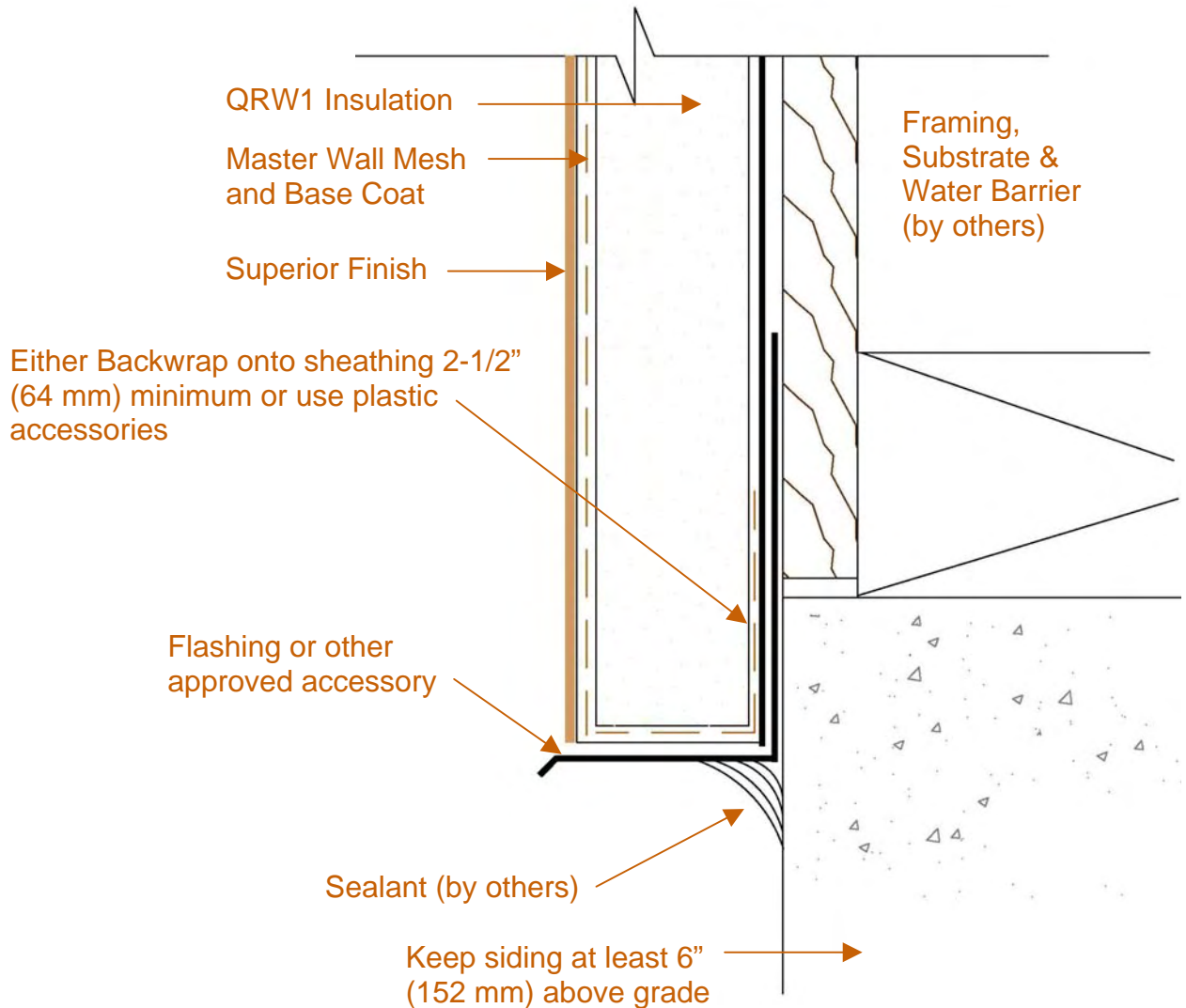

## QR-16 Termination at Foundation Detail

These drawings relay the conceptual conditions of Master Wall Systems and are not the construction drawings. Ultimately the design and detailing of an entire wall system is the responsibility of a professional. These details will guide the design professional in the use of Master Wall Products. Master Wall disclaims design, warranty or construction intent or responsibility.



# QRW1 Drainage EIFS

## Conceptual Details

Corporate • P.O. Box 397 • Fortson • Georgia • 31808 • 800-755-0825 • FAX 706-569-6704

Technical • 800-760-2861 • FAX 734-433-0930

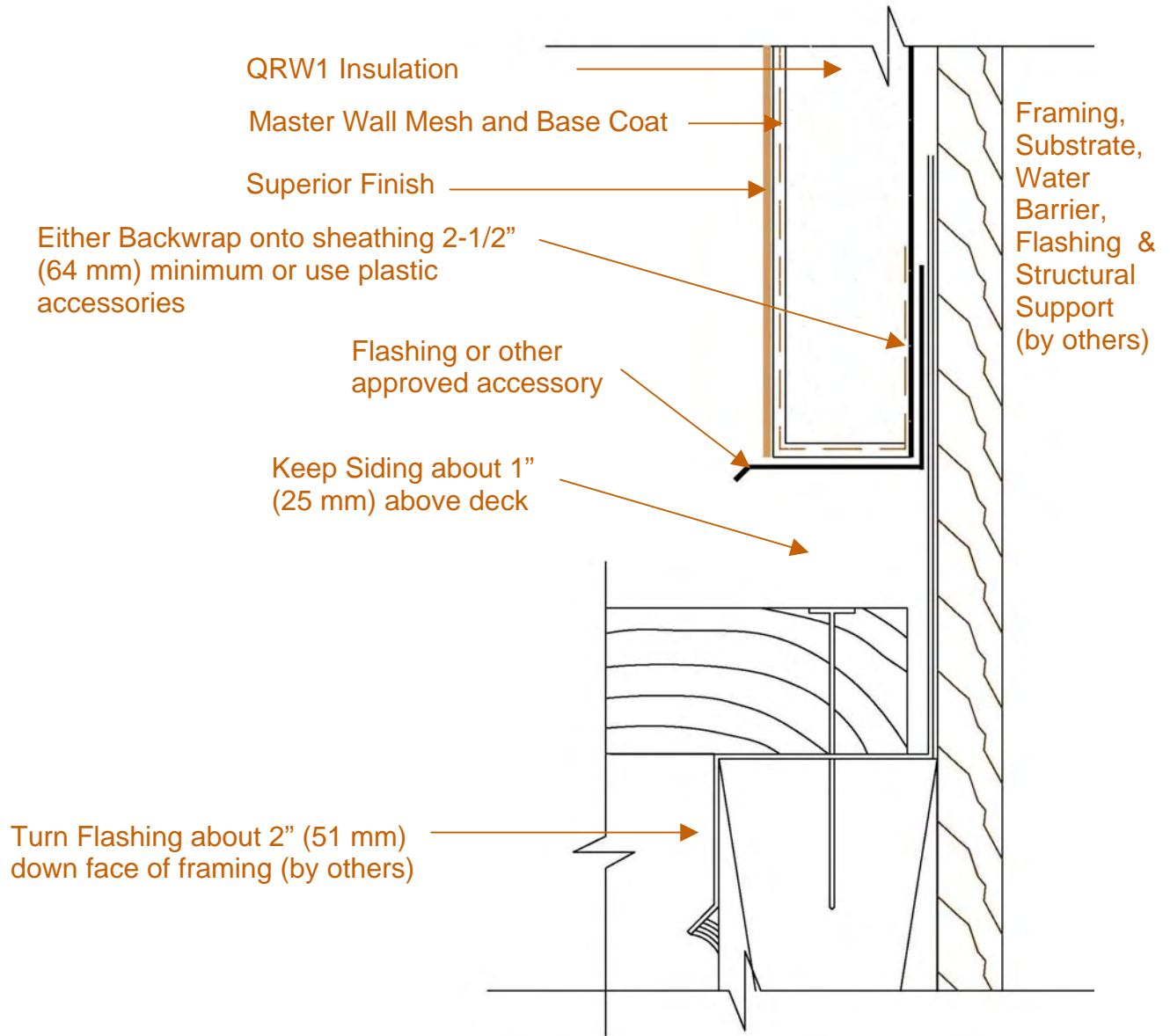

## QR-17 Termination at Decking

These drawings relay the conceptual conditions of Master Wall Systems and are not the construction drawings. Ultimately the design and detailing of an entire wall system is the responsibility of a professional. These details will guide the design professional in the use of Master Wall Products. Master Wall disclaims design, warranty or construction intent or responsibility.



## QRW1 Drainage EIFS

### Conceptual Details

Corporate • P.O. Box 397 • Fortson • Georgia • 31808 • 800-755-0825 • FAX 706-569-6704

Technical • 800-760-2861 • FAX 734-433-0930

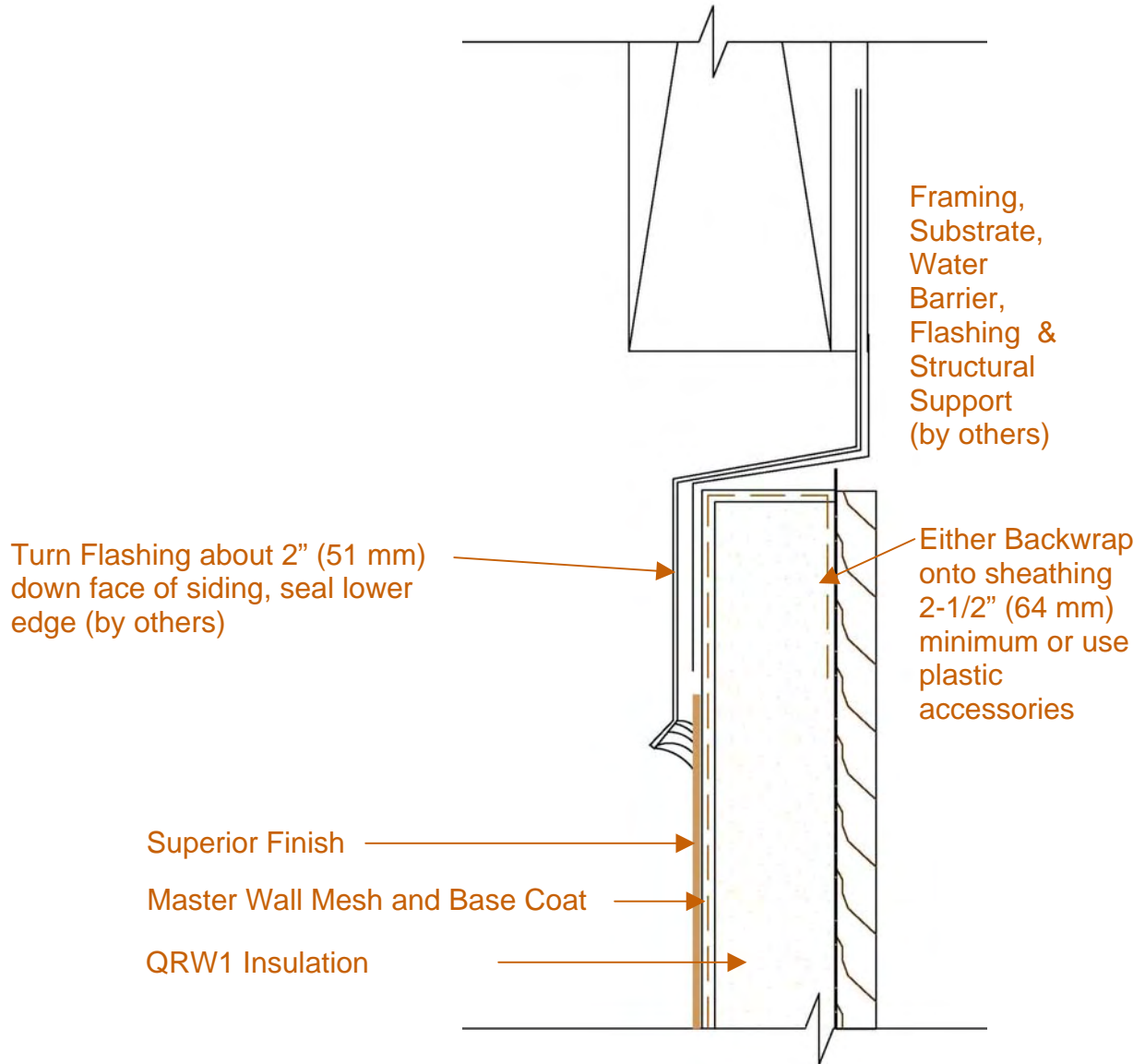

## QR-18 Termination Under Deck

These drawings relay the conceptual conditions of Master Wall Systems and are not the construction drawings. Ultimately the design and detailing of an entire wall system is the responsibility of a professional. These details will guide the design professional in the use of Master Wall Products. Master Wall disclaims design, warranty or construction intent or responsibility.



## QRW1 Drainage EIFS

### Conceptual Details

Corporate • P.O. Box 397 • Fortson • Georgia • 31808 • 800-755-0825 • FAX 706-569-6704

Technical • 800-760-2861 • FAX 734-433-0930

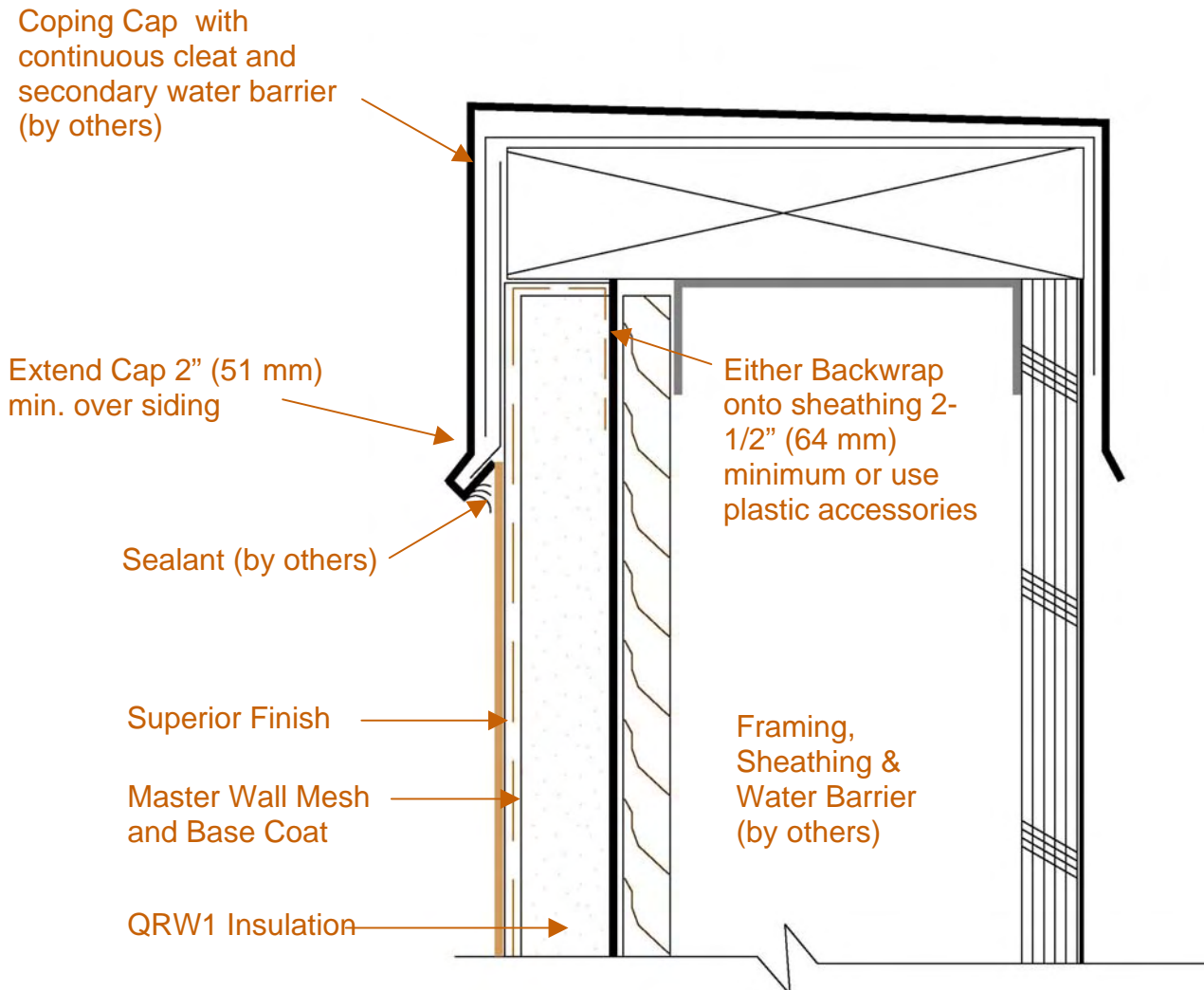

## QR-19 Cap Detail

These drawings relay the conceptual conditions of Master Wall Systems and are not the construction drawings. Ultimately the design and detailing of an entire wall system is the responsibility of a professional. These details will guide the design professional in the use of Master Wall Products. Master Wall disclaims design, warranty or construction intent or responsibility.



## QRW1 Drainage EIFS

Conceptual Details

Corporate • P.O. Box 397 • Fortson • Georgia • 31808 • 800-755-0825 • FAX 706-569-6704

Technical • 800-760-2861 • FAX 734-433-0930

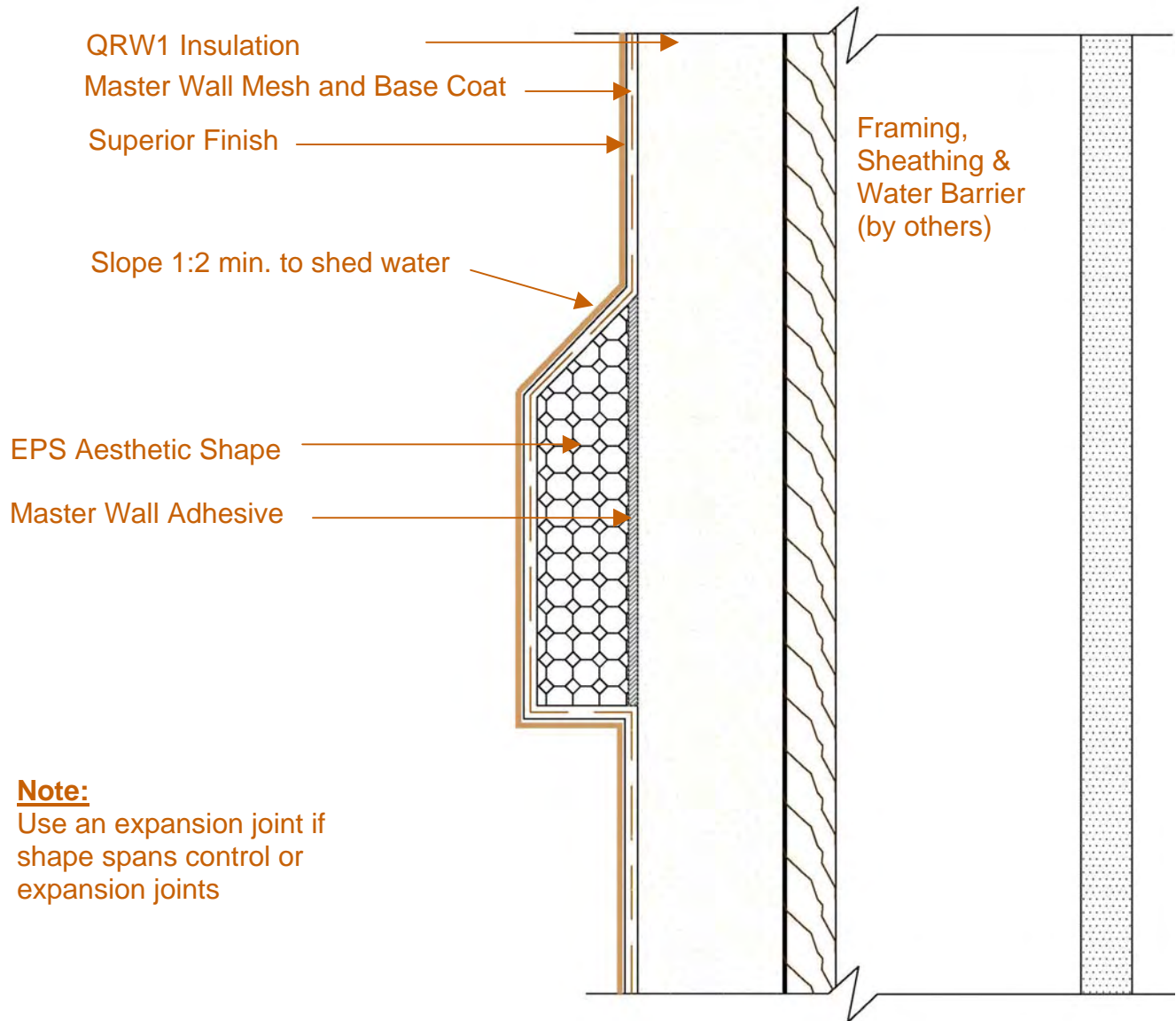

**Note:**

Use an expansion joint if shape spans control or expansion joints

## QR-20 EPS Shape Detail

These drawings relay the conceptual conditions of Master Wall Systems and are not the construction drawings. Ultimately the design and detailing of an entire wall system is the responsibility of a professional. These details will guide the design professional in the use of Master Wall Products. Master Wall disclaims design, warranty or construction intent or responsibility.



## QRW1 Drainage EIFS

### Conceptual Details

Corporate • P.O. Box 397 • Fortson • Georgia • 31808 • 800-755-0825 • FAX 706-569-6704

Technical • 800-760-2861 • FAX 734-433-0930

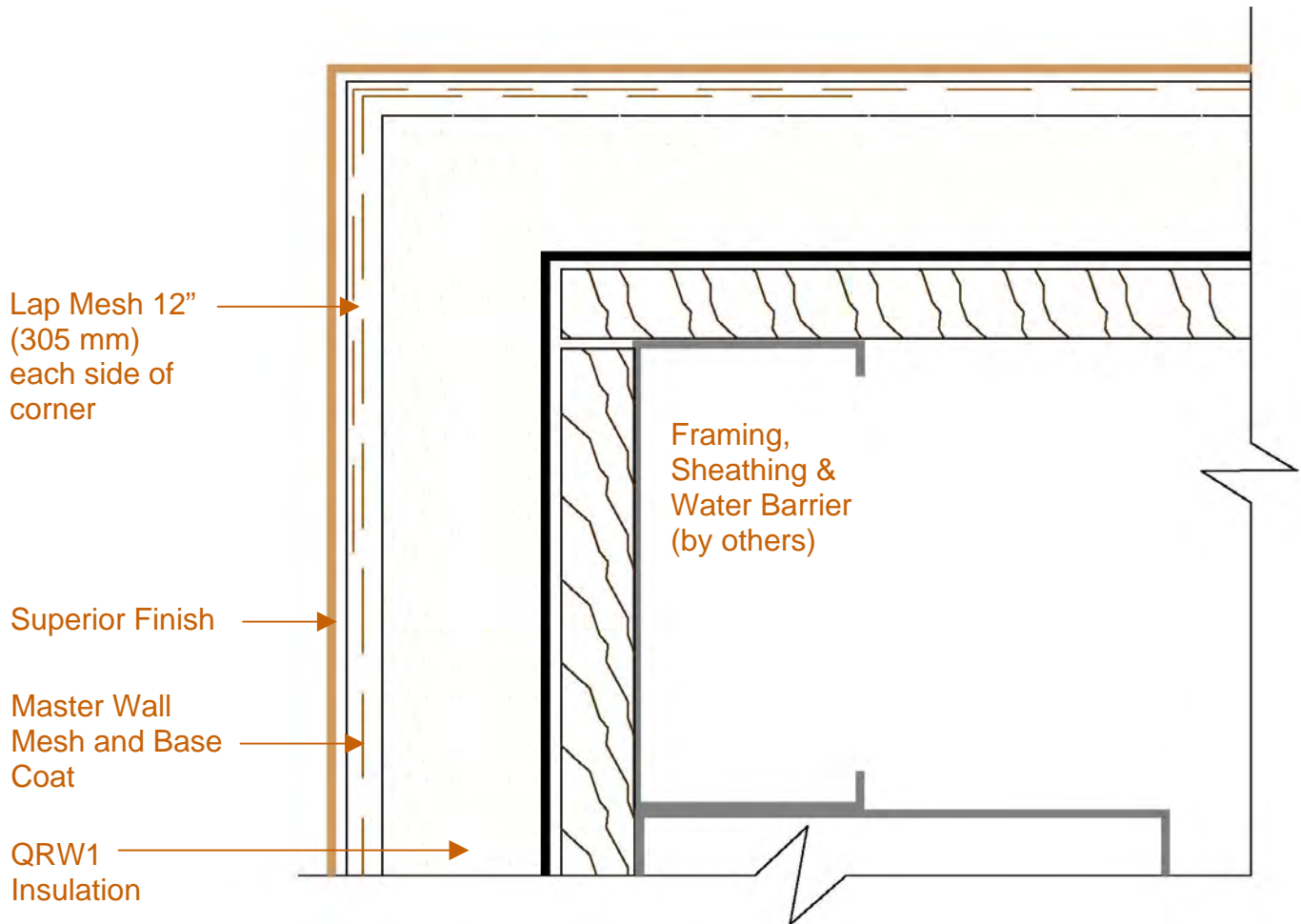

## QR-21 Corner Detail

These drawings relay the conceptual conditions of Master Wall Systems and are not the construction drawings. Ultimately the design and detailing of an entire wall system is the responsibility of a professional. These details will guide the design professional in the use of Master Wall Products. Master Wall disclaims design, warranty or construction intent or responsibility.



## QRW1 Drainage EIFS

### Conceptual Details

Corporate • P.O. Box 397 • Fortson • Georgia • 31808 • 800-755-0825 • FAX 706-569-6704

Technical • 800-760-2861 • FAX 734-433-0930

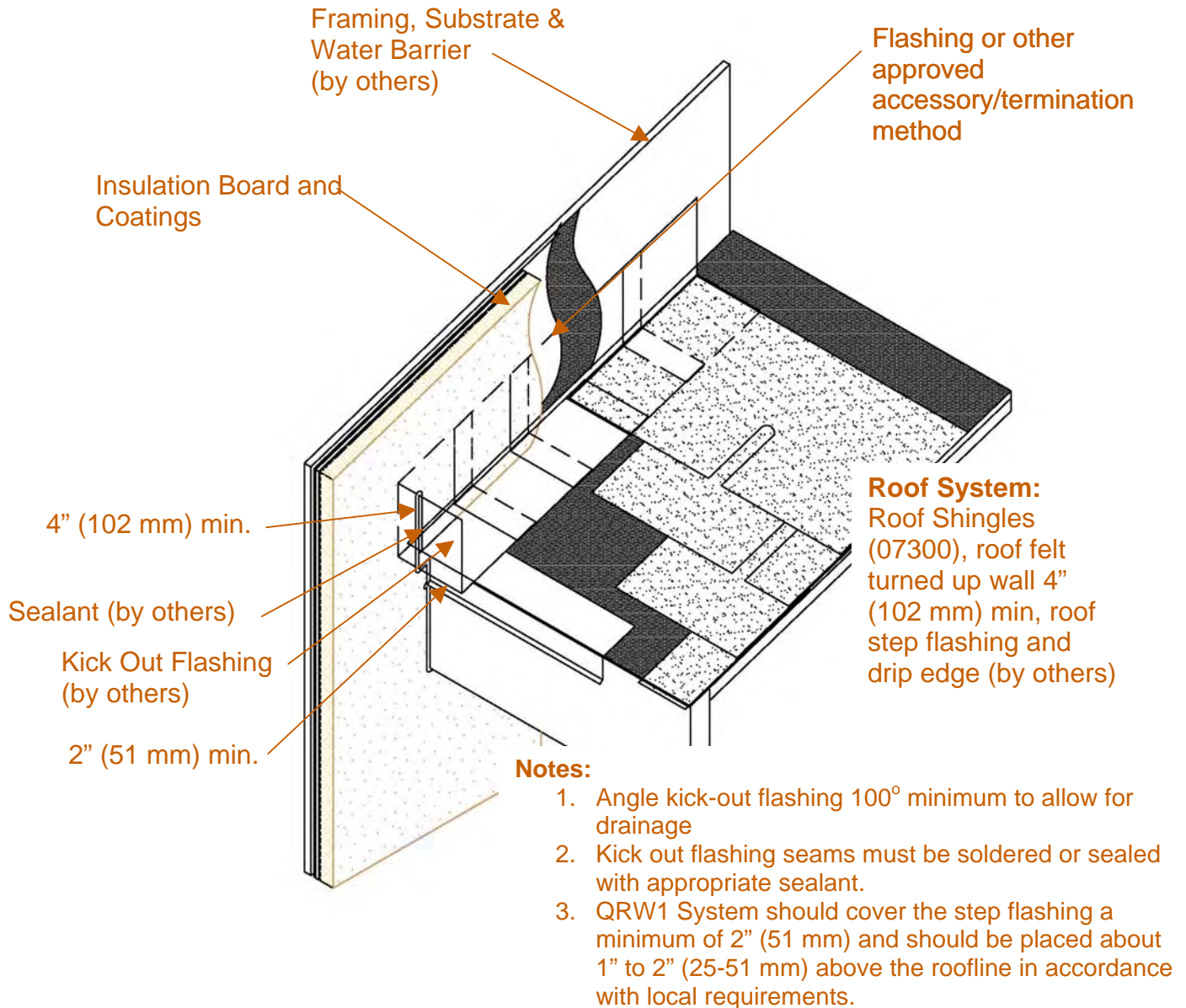

## QR-22 Typical Roof/Wall Intersection

These drawings relay the conceptual conditions of Master Wall Systems and are not the construction drawings. Ultimately the design and detailing of an entire wall system is the responsibility of a professional. These details will guide the design professional in the use of Master Wall Products. Master Wall disclaims design, warranty or construction intent or responsibility.



**Master Wall, Inc**  
**Building a Culture of Excellence**

QRW1

## Drainage EIFS

### 5 Year Labor & Material Limited Warranty

Master Wall Inc. warrants the properly designed and installed QRW1 Drainage Exterior Insulation and Finish System and materials for 5 years from the date of installation. Master Wall Inc.'s exclusive liability under this warranty is to supply replacement materials and labor or corrective procedures, if it is shown that the materials supplied by Master Wall Inc., were defective when installed by the Master Wall Inc. certified applicator. Remedies shall be solely determined by Master Wall Inc. and no other warranties are expressed or implied. For a valid warranty, the system and products must be installed in accordance with Master Wall Inc.'s written recommendations, specifications, details, bulletins and other project-specific written recommendations. Master Wall Inc. must be notified in writing within 10 business days of the original discovery of the defect.

Master Wall Inc., is not responsible for structural conditions, design conditions beyond those noted in our literature, architecture, engineering or workmanship of any project. Drainage Systems are warranted to drain incidental water for the warranty period. Materials must be properly stored and applied in a timely manner. Workmanship, aesthetics and installation are beyond the scope of this warranty as are any deviations from Master Wall Inc. Documents not specifically approved in writing.

Abuse, misuse, excessive weather or environmental conditions beyond what the products or systems have been tested, designed or approved for is expressly limited. Certain colors with organic pigments are less fade-resistant than others. The building, system and products must be properly maintained in accordance with Master Wall Inc., documents, local environmental conditions and good building practices. In no case is Master Wall Inc. responsible for incidental and consequential damages.

**This warranty becomes effective only when all bills for the components of the system have been paid.**

**Except as stated, Master Wall, Inc., expressly disclaims any warranty of merchantability or fitness for a particular purpose. The above remedies are to be deemed exclusive.**

Project:

Applicator:

Warranty Date: