



Submittal Package

One Coat Stucco (OCS) Level II

Project:

Location:

Architect:

General Contractor:

Applicator:

Benefits of Master Wall

- American owned and privately managed, our focus is the customer
- 20+ year track record, projects from coast to coast
- Quality products featuring 100% pure acrylic polymers
- Dedicated to the EIFS & Stucco Markets, it's **what** we do, not part of what our company does
- Experienced Staff—100+ years of experience
- Service—we provide it!
 - Job site visits
 - Color matching
 - Architectural Support
 - Samples
 - Plan, detail and technical reviews
- Dedicated to a culture of excellence

More Information



OCS Fiberstucco

Submittal Information:

- *System Data Sheets*
- *Product Data Sheets*
- *Specifications*
- *Details*
- *Sample Labor/Material Limited Warranty*

Manufactured by



P. O. Box 397
Fortson, GA 31808
800-755-0825
Technical 800-760-2861
www.masterwall.com

OCS

Fiberstucco
Fibered One Coat Stucco

M Master Wall Inc.
Building a Culture of Excellence



M A I



masterwall.com

Corporate Office P.O. Box 397 Fortson, GA 31808 800.755.0825



09 24 00 / 09 25 00

OCS *Fiberstucco*
Fibered One Coat Stucco

More Choices...More Warranties

Master Wall OCS Fiberstucco is an engineered, fiber-reinforced one coat stucco. It offers the durability of traditional stucco with easier application and a thinner cross section.

OCS Fiberstucco is available as a basic system (stucco & finish) or it can be upgraded with additives, rainscreens, leveling base coats and finishes.

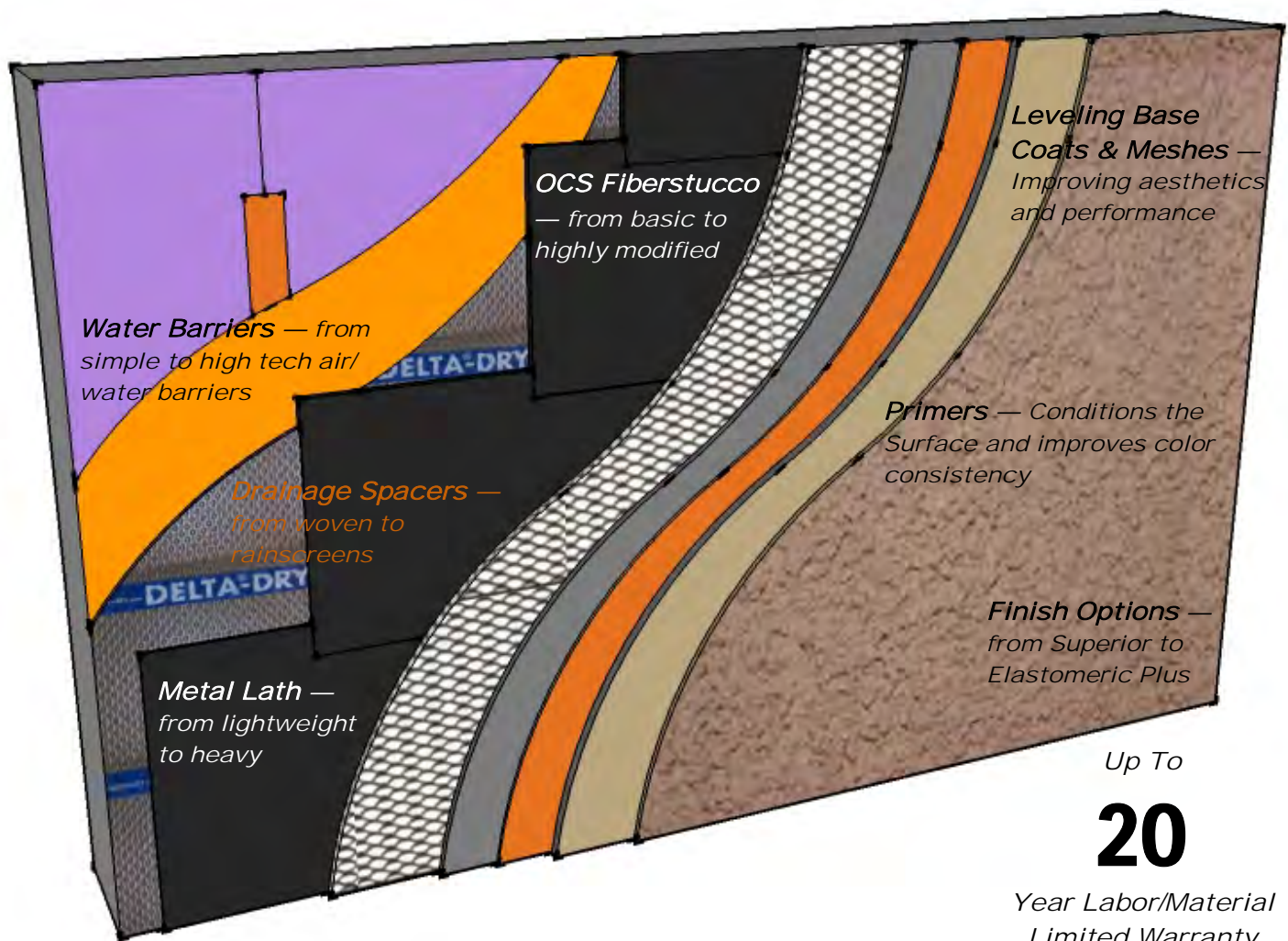

M **Master Wall Inc.**
Building a Culture of Excellence

©2011 Master Wall Inc.

P. O. Box 397
Fortson, GA 31808
800-755-0825
Technical 800-760-2861
www.masterwall.com

010111

Available Options

Weather Resistive Barriers (WRB)

WRB's provide secondary weather protection for the stucco application. A minimum of two layers is required over sheathing applications. For CMU and masonry, many architects are specifying secondary protection as well.

- 2-layers of ASTM D226 Asphalt Felt (over sheathing) – Minimum requirement
- 1-layer of Tyvek® StuccoWrap® with 1-layer of ASTM D226 Asphalt Felt – Improved weather protection with an easier installation.
- Master Wall Rollershield with 1-layer of ASTM D226 Asphalt Felt (over sheathing) – Fluid applied Rollershield offers 100% weather protection and doesn't rattle in the wind. It can be flashed into openings and has an extremely low air infiltration rate.
- Master Wall Rollershield over concrete or masonry – The same benefits of Rollershield over sheathing. No additional water barriers are required, lath must be used.

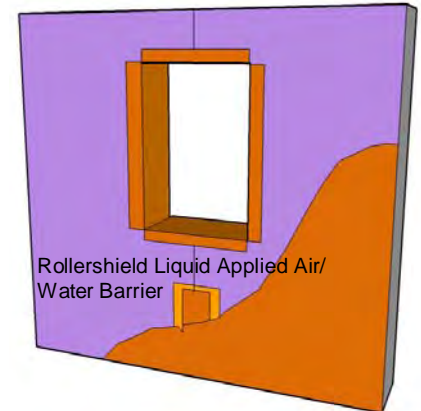

Drainage Mats or Spacers (DRS)

Providing even a small drainage space may be desired in certain climates to form a true capillary break in the wall system. Options range from simple drainage mats to true rainscreen protection.

- None – Follows traditional stucco application practices.
- Drainage Mat – Manufactured by Colbond, Keene or Benjamin Obdyke, these products use a randomly woven mat to provide a slight space for drainage. Place drainage mats between water barriers.
- Rainscreen: Cosella-Dörken Delta®-Dry offers a true ventilated rainscreen and pressure-equalized construction. Place Delta®-Dry between water barriers and provide ventilation at top and bottom.



Master Wall (OCS) Fiberstucco

Our OCS Fiberstucco has a decades-long track record of performance. It's manufactured with fibers and proprietary ingredients and independently tested to perform better than traditional stucco. Our OCS can be applied direct to concrete or masonry and offers a variety of applications with metal mesh or lath.

Stucco Additives (SA)

Master Wall Stucco Ad-Liquid improves the performance of the stucco. The 100% acrylic formulation is mixed into the OCS at different levels to improve durability and crack resistance. Our BA57 bonding agent can be specified as the bonding agent when applying OCS over porous concrete or masonry.

Leveling Base Coats (LBC)

Master Wall base coats mix smooth and creamy. When applied over OCS they can fine-tune the surface, making the finish application look better. Embedding Master Wall Standard Mesh into the base coat improves the crack resistance of the OCS as well as helping level the surface.

Finishing Options and Finish Additives (PRIME, FA & FIN)

Priming the wall with Master Wall Primecoat or Sanded Primecoat conditions the surface and extends finish coverage. Silicone Coat adds silicone to the finishes for better water resistance and Excel Protection boosts the finishes resistance to mold and mildew growth.

Master Wall Superior Finishes are manufactured with 100% pure acrylic polymers and feature Dirt Pickup Resistance (DPR). Our flexible Superior Elastomeric Plus finishes help bridge minor hairline cracks in stucco.



Warranty Extension Options

Corporate: 800-755-0825

Technical: 800-760-2861

Item	Description	Term*	✓
Weather Resistive Barriers (WRB) and Drainage Spacers (DRS)			
WRB01	2- ASTM D226 Asphalt Felt (minimum over sheathing)	0	<input checked="" type="checkbox"/>
WRB02	Tyvek® StuccoWrap® or similar with 1-layer of ASTM D226 Asphalt Felt (over sheathing)	0	<input type="checkbox"/>
WRB03	Master Wall Rollershield with 1-layer of ASTM D226 Asphalt Felt (over sheathing)	5	<input type="checkbox"/>
WRB04	Master Wall Rollershield (over concrete or masonry, lath required)	5	<input type="checkbox"/>
DRS00	No Spacer	0	<input type="checkbox"/>
DRS01	Drainage Mat: Colbond, Keene, Benjamin Obdyke	0	<input type="checkbox"/>
DRS02	Rainscreen: Cosella-Dörken Products, Inc. Delta® -Dry, Delta® -Dry Plus	1	<input type="checkbox"/>
OCS Fiberstucco (OCS)			
OCS01	Master Wall OCS Fiberstucco with 17 ga. woven wire fabric reinforcement, 3/8" thick	2	<input type="checkbox"/>
OCS02	Master Wall OCS Fiberstucco direct to Masonry/Concrete (no Rollershield), 3/8"-1/2" thick	3	<input checked="" type="checkbox"/>
OCS03	Master Wall OCS Fiberstucco with 2.5#/sy self-furring reinforcement, 1/2" thick	3	<input type="checkbox"/>
OCS04	Master Wall OCS Fiberstucco with 3.4#/sy self-furring reinforcement, 3/4" thick	4	<input type="checkbox"/>
Stucco Additives (SA)			
SA00	None	0	<input type="checkbox"/>
SA01	Master Wall Stucco Ad Liquid, 3 qt per mix of OCS Concentrate, 1 qt per bag of Ready OCS	1	<input checked="" type="checkbox"/>
SA02	Master Wall Stucco Ad Liquid, 2 gal per mix of OCS Concentrate, 3 quarts per bag of Ready OCS	2	<input type="checkbox"/>
SA03	Master Wall Stucco Ad Liquid, 5 gal per mix of OCS Concentrate, 1-1/2 gal per bag of Ready OCS	3	<input type="checkbox"/>
Leveling Base Coats (LBC)			
LBC00	None	0	<input checked="" type="checkbox"/>
LBC01	F&M, F&M Plus, MBB or Guardian Skim Coat	1	<input type="checkbox"/>
LBC02	F&M, F&M Plus, MBB or Guardian Skim Coat with Master Wall Standard Reinforcing Mesh	2	<input type="checkbox"/>
Primers (PRIME), Finish Additives (FA), Finish Options (FIN)			
PRIME00	No Primer	0	<input type="checkbox"/>
PRIME01	Primecoat or Sanded Primecoat tinted primer	1	<input checked="" type="checkbox"/>
FIN01	Superior Finish	1	<input checked="" type="checkbox"/>
FA01	Excel Additive (to any finish)	0.5	<input type="checkbox"/>
FA02	Silicone Coat (to any finish)	0.5	<input type="checkbox"/>
FIN02	Superior Elastomeric Plus Finish	3	<input type="checkbox"/>

Example of basic system: WRB01 (0) + OCS03 (3) with PRIME01 (1) and FIN01 (1) = 5 year warranty

*minimum requirement for warranty: OCS and finish

Total Warranty Years

With Master Wall, your options add up!



masterwall.com

SUPERIOR *finishes*

Integrally Colored Textured Acrylic Finishes



Perfect Texture



Spray Texture



Desert Sand Texture



R-Coarse Texture



Refinish Texture



M Master Wall Inc.
Building a Culture of Excellence



Superior Finish is Master Wall's textured finish line. Available in standard or custom colors, Superior Finishes may be applied over Master Wall Base Coats or prepared substrates including brick, masonry, concrete and stucco. Superior Finishes work great for interior applications as well. Superior Finish is available in five-gallon (19L) pails and is typically troweled onto the wall surface with a stainless steel trowel.

Estimated Coverage

Perfect: 120-150 sf/pail (11-14 sm)
Spray SS: 215-225 sf/pail (20-21 sm)
Desert Sand SS: 130-150 sf/pail (12-14 sm)
R-Coarse: 90-120 sf/pail (8.4-11 sm)
Perfect West: 140-160 sf/pail (13-15 sm)
Refinish: Varies with Texture

Coverage will vary by application, applicator skill and substrate conditions. Master Wall assumes no responsibility nor liability for coverage.

Finish Properties

Meets or Exceeds:
ASTM E84 Surface Burning
ASTM E108 Flame Spread
ASTM C67 Freeze/Thaw
ASTM E2485/2570 Freeze/Thaw
ASTMD2247/E2570 Humidity
ASTM D3273 Mold/Mildew
ASTM D968 Abrasion
ASTM B117 Salt Spray
ASTM G53 Weathering
ASTM G23/G154/G155 Weathering

Approved Substrates

Master Wall Base Coats
Stucco
Prepared & Base Coated Surfaces of:
Brick
Concrete
Masonry
Others approved in writing

Statistics

Pail Weight: 70 lbs (32 kg), Refinish 65 lbs (29.5 kg)

Working Time: 1/4 hour @ room temperature

Drying Time: 8-12 hours to set, 48-72 hours to dry @ room temperature. High pigment levels, low temperatures, high humidity extend dry times.

Application Range: 40°-110°F (5°-43°C)

Shelf Life: 2 years

Application Procedure

Job Conditions - Air and substrate temperature for application of Superior Finishes must be 40°F (5°C) or higher and must remain 40°F (5°C) or higher for a minimum of 24 hours. Provide temporary protection to protect the wall system from damage until permanent flashings, caps and sealants are installed. Store materials within prescribed temperature limits and out of direct sunlight. High temperatures will reduce working times, Low temperatures and/or high humidity will extend working, set and dry times.

Preparation - The substrate must be approved by Master Wall Inc., clean, dry, structurally sound and free of efflorescence, oil, grease, form release agents and curing compounds or anything that would affect bond. Painted surfaces are not acceptable and must be removed. Concrete and surfaces should cure for a minimum of 28 days. Stucco should be cured until clean, dry and hard—typically 14 days.

Interior drywall should be finished and made ready for paint. Prime surfaces with Primecoat/Sanded Primecoat primer prior to finishing.

Base Coats - Must be flat, dry hard, and free of efflorescence. Master Wall base coats must cure a minimum of 12 hours before application of Superior Finish. Substrates of brick, masonry or concrete should be leveled smooth using either Master Wall base coats or stucco.

Mixing - Thoroughly stir Superior Finish using a heavy duty 1/2" drill at 400 - 500 rpm and a heavy duty mixing paddle. Small amounts of clean, potable water may be added to obtain a workable consistency. To avoid color variations, add the same amount of water to each pail. Do not exceed 24 ounces (0.7L) of water per pail of finish.

Application — Apply a uniform thickness (about 1/16") of Superior Finish to the substrate using a stainless steel trowel. Spread evenly and then scrape the finish coat down to a thickness no greater than the largest aggregate in the material. Immediately float the finish coat using a plastic float to the desired texture. Always maintain a wet edge to achieve uniformity of texture and color.

For Professional Results

- Apply finish coats away from direct sunlight. Cold joints or color variations can occur if the finish dries too quickly.

- Consider priming stucco surfaces with Primecoat/Sanded Primecoat to even out finish absorption.
- Surfaces exposed to the weather must be sloped (6:12 minimum).
- Under certain conditions dark colors may show efflorescence on the surface during the cure process.
- Finishes are intended for the approved substrates listed above and should not be applied directly to gypsum board or insulation board products.

Clean Up—Tools and equipment can be cleaned with soapy water while the Superior Finish is still wet.

Available Options



Elastomeric Additive



Silicone Additive



Excel Mildew Additive



Master Wall Inc.
Building a Culture of Excellence

P. O. Box 397
Fortson, GA 31808

800-755-0825

Technical 800-760-2861

masterwall.com

050111

Information contained in this product data sheet conforms to the standard detail recommendations and specifications for the installation of Master Wall Inc. products and is presented in good faith. Master Wall Inc. assumes no liability, expressed or implied as to the architecture, engineering, or workmanship of any project. This information may be concurrent with, or superseded by other applicable documents, such as specifications and details. Contact Master Wall Inc. for the most current product information.



Primecoat



Primecoat is a 100% pure acrylic tinted

Stucco & Base Coat Primer

Integrally Colored

primer with very good hiding power. It is designed for compatibility with Master Wall Superior Finishes, base coats, traditional stucco, One Coat Stucco and cement products.

Primecoat is available in all Master Wall colors and custom colors delivered in five-gallon (19L) pails.

Approved Substrates

- Master Wall Base Coats
- Concrete
- Brick
- Masonry
- Stucco
- One Coat Stucco
- Cement Composition Siding
- Others approved in writing

Application Procedure

Job Conditions - Air and substrate temperature for application of Primecoat must be 40°F (5°C) or higher and must remain 40°F (5°C) or higher for a minimum of 24 hours. Provide temporary protection to protect the wall system from damage until permanent flashings, caps and sealants are installed. Store materials within prescribed temperature limits and out of direct sunlight. Working and drying times are based upon normal room temperature conditions and will vary with temperature and humidity.

Preparation - The substrate must be approved by Master Wall Inc., clean, dry, structurally sound and free of efflorescence, oil, grease, form release agents and curing compounds or anything that would affect bond. Painted surfaces are not acceptable and must be removed.

Concrete – Must have cured a minimum of 28 days prior to the application of Primecoat. If form release agents or curing compounds exist on the surface, they must be removed with a solution of muriatic acid or similar product (with appropriate precautions). Remove any residual acid by flushing with water. All projections must be removed and any voids filled with F&M, F&M Plus, or MBB.

Masonry – Skim coat with F&M, F&M Plus, or MBB to achieve a smooth level surface. If joints are not struck flush, multiple coats may be required. Contact Master Wall for more information.

Stucco – Must have cured for a minimum of 7-14 days and be clean, dry and hard prior to the application of Primecoat. If additives were used in the stucco, it is recommended that a test patch be made to evaluate bond strength of the Primecoat to the stucco.

Master Wall Base Coats or Finishes/Previously Painted Surfaces/Cement Composition Siding—Install and prepare according to published guidelines. Surfaces should be clean, dry, cured and ready to receive coatings.

Mixing - Thoroughly stir Primecoat into a homogenous consistency. Small amounts of clean, potable water may be added to obtain a workable consistency. Do not over mix. Do not exceed 24 ounces (0.7L) of water per pail. Do not add accelerators or retarders to Primecoat.

Application – Primecoat can be applied by brush, roller, or airless spray equipment. When using a roller, a maximum ¾" (19 mm) nap is recommended. Apply Primecoat in an even, continuous coat of about 3 mils, maintaining a wet edge.

Clean Up

Tools and equipment can be cleaned with soapy water when Primecoat is wet.

Limitations

Primecoat is not intended for use as the final finish coat over Master Wall base coats or other approved substrates.

Statistics

Coverage (Estimated/varies)

1-Coat: 1000-1200 sf (93-112 sm)

Pail Weight: 53 lbs (24kg)

Dry to Touch: 1 hour @ room temperature

Recoat Time: 2 hours @ room temperature

Drying Time: 12 hours @ room temperature

Application Range: 40°-110°F (5°-43°C)

Shelf Life: 2 years



Information contained in this product data sheet conforms to the standard detail recommendations and specifications for the installation of Master Wall Inc. products and is presented in good faith. Master Wall Inc. assumes no liability, expressed or implied as to the architecture, engineering, or workmanship of any project. This information may be concurrent with, or superseded by other applicable documents, such as specifications and details. Contact Master Wall Inc. for the most current product information.

P. O. Box 397
Fortson, GA 31808
800-755-0825
Technical 800-760-2861
www.masterwall.com



Master Wall OCS is a fibered type Portland cement-based bagged stucco with exceptional workability, open working time, water retention, early strength, shrinkage resistance and long-term durability. OCS is typically applied thinner than traditional stucco and is mixed at time of use with sand and water.

One Coat Stucco Concentrate: Add Sand & Water

Application Procedure

Job Conditions - Air and substrate temperature for application of OCS must be 40°F (5°C) or higher and must remain 40°F (5°C) or higher for a minimum of 24 hours. Provide temporary protection to protect the wall system from damage until permanent flashings, caps and sealants are installed. Store materials in a dry place, within prescribed temperature limits and out of direct sunlight. Working and drying times are based upon normal room temperature conditions and will vary with temperature and humidity.

Preparation - The substrate must be approved by Master Wall Inc., clean, dry, structurally sound and free of efflorescence, oil, grease, form release agents and curing compounds or anything that would affect bond. Painted surfaces are not acceptable and must be removed or metal lath applied. All sheathed applications must receive a minimum of 2-layers code-approved asphalt felt or equivalent.

Prepare smooth or non-absorbent solid substrates by one of the following methods or a combination; Sandblasting, chipping or acid etching, A dash-bond coat applied forcefully, Bonding compounds such as Master Wall *Stucco Ad Liquid* or BA57, Furred or self-furring metal plaster bases as per ASTM C1063.

Mixing - Each bag of OCS is mixed with 200 lbs (90.7 kg) of sand aggregate (ASTM C897 or ASTM C144) and clean, potable water (200 lbs is roughly 2.5 cubic feet (0.07 cubic meters) of clean, damp-loose sand or 2-3/4 Master Wall pails, filled). Using a clean mixer, first add 1/2 to 2/3 the water required, 1/2 the sand, 1 bag OCS, then the rest of the sand and water to achieve the desired workability. Mix materials for 3 to 5 minutes after all materials are in the mixer. Total water content can vary between 4 to 6.5 gallons (15-24.5L). *Stucco Ad-Liquid* may also be used instead of an equal amount of water (up to 5 gallons, 18.9L). See system data sheet for specific levels required for increased warranties.

Tempering—The mixed stucco can be re-tempered one time within 1 hour. Material older than 1-1/2 hours should be discarded.

Application

Apply OCS by hand or machine to a minimum nominal thickness of 3/8" (9.5 mm) for masonry, concrete and stucco applications. Measure stucco coat thickness from the back of the metal plaster base not including ribs and dimples or from the face of solid substrates exclusive of texture variations. Where plaster abuts dissimilar materials, provide for separation. To avoid cold joints the application should stop at corner angles, rustications, openings and control joints.

On metal plaster bases, apply OCS with sufficient material and pressure to totally embed the metal base. A second pass may be required to obtain the minimum thickness of 3/8" (9.5 mm), 1/2" (12.7 mm) suggested for better lath coverage. Rod or straight edge the surface to provide an even base for the *Superior Finish*.

On solid plaster bases, dampen high-suction bases with clean water, BA57 or *Stucco Ad-Liquid* prior to the application of OCS. Rod or straight edge the surface to provide an even base for the *Superior Finish*.

Statistics

Coverage (Estimated/varies)

3/8" (9.5 mm) thick: 80 sf (7.4 sm)

1/2" (12.7 mm) thick : 70 sf (6.5 sm)

3/4" (19 mm) thick: 40 sf (3.7 sm)

Bag Weight: 80 lbs (36 kg)

Working Time: 1-1/2 hours @ room temperature

Curing Time: 24 hours @ room temperature

Application Range: 40°-110°F (5°-43°C)

Shelf Life: 1 year

Curing—Moist cure using fogging, plastic films or other method acceptable to the design professional for 48-72 hours. Mixes with *Stucco Ad-Liquid* do not need moist curing. Allow to fully cure until clean, dry and hard before finishing—typically 7-14 days. See Master Wall Technical Bulletins and data sheets for additional curing, drying and application recommendations.

Clean Up—Tools and equipment can be cleaned with soapy water while the OCS mixture is still wet.



P. O. Box 397
Fortson, GA 31808

800-755-0825

Technical 800-760-2861

www.masterwall.com

Information contained in this product data sheet conforms to the standard detail recommendations and specifications for the installation of Master Wall Inc. products and is presented in good faith. Master Wall Inc. assumes no liability, expressed or implied as to the architecture, engineering, or workmanship of any project. This information may be concurrent with, or superseded by other applicable documents, such as specifications and details. Contact Master Wall Inc. for the most current product information.



Ready OCS



Master Wall Ready OCS is a fibered type **One Coat Stucco** Add Water
Portland cement-based bagged stucco with

exceptional workability, open working time, water retention, early strength, shrinkage resistance and long-term durability. OCS is typically applied thinner than traditional stucco and is mixed at time of use with water.

Application Procedure

Job Conditions - Air and substrate temperature for application of Ready OCS must be 40°F (5°C) or higher and must remain 40°F (5°C) or higher for a minimum of 24 hours. Provide temporary protection to protect the wall system from damage until permanent flashings, caps and sealants are installed. Store materials in a dry place, within prescribed temperature limits and out of direct sunlight. Working and drying times are based upon normal room temperature conditions and will vary with temperature and humidity.

Preparation - The substrate must be approved by Master Wall Inc., clean, dry, structurally sound and free of efflorescence, oil, grease, form release agents and curing compounds or anything that would affect bond. Painted surfaces are not acceptable and must be removed or metal lath applied. All sheathed applications must receive a minimum of 2-layers code-approved asphalt felt or equivalent.

Prepare smooth or non-absorbent solid substrates by one of the following methods or a combination; Sandblasting, chipping or acid etching, A dash-bond coat applied forcefully, bonding compounds such as Master Wall Stucco Ad Liquid or BA57, Furred or self-furring metal plaster bases as per ASTM C1063.

Mixing - Each bag of Ready OCS is mixed clean, potable water. Using a clean mixer, first add 1/2 to 2/3 the water required, 1 bag Ready OCS, then the rest of the water to achieve the desired workability. Mix materials for 3 to 5 minutes after all materials are in the mixer. Total water content can vary between 1 to 1.5 gallons (3.8-5.7L). Stucco Ad-Liquid may also be used instead of an equal amount of water. See system data sheet for specific levels required for increased warranties.

Tempering—The mixed stucco can be re-tempered one time within 1 hour. Material older than 1-1/2 hours should be discarded.

Application

Apply OCS by hand or machine to a minimum nominal thickness of 3/8" (9.5 mm) for masonry, concrete and stucco applications. Measure stucco coat thickness from the back of the metal plaster base not including ribs and dimples or from the face of solid substrates exclusive of texture variations. Where plaster abuts dissimilar materials, provide for separation. To avoid cold joints the application should stop at corner angles, rustications, openings and control joints.

On metal plaster bases, apply Ready OCS with sufficient material and pressure to totally embed the metal base. A second pass may be required to obtain the minimum thickness of 3/8" (9.5 mm), 1/2" (12.7 mm) suggested for better lath coverage. Rod or straight edge the surface to provide an even base for the Superior Finish.

On solid plaster bases, dampen high-suction bases with clean water, BA57 or Stucco Ad-Liquid prior to the application of Ready OCS. Rod or straight edge the surface to provide an even base for the Superior Finish.

Curing—Moist cure using fogging, plastic films or other method acceptable to the design professional for 48-72 hours. Mixes with Stucco Ad-Liquid do not need moist curing. Allow to fully cure until clean, dry and hard before finishing—typically 7-14 days. See Master Wall Technical Bulletins and data sheets for additional curing, drying and application recommendations.

Clean Up—Tools and equipment can be cleaned with soapy water while the Ready OCS mixture is still wet.

Statistics

Coverage (Estimated/varies)

- 3/8" (9.5 mm) thick: 22 sf (2 sm)
- 1/2" (12.7 mm) thick: 20 sf (1.8 sm)
- 3/4" (19 mm) thick: 11 sf (1 sm)

Bag Weight: 80 lbs (36 kg)

Working Time: 1.5 hours @ room temperature

Drying Time: 24 hours @ room temperature

Application Range: 40°-110°F (5°-43°C)

Shelf Life: 1 year



Information contained in this product data sheet conforms to the standard detail recommendations and specifications for the installation of Master Wall Inc. products and is presented in good faith. Master Wall Inc. assumes no liability, expressed or implied as to the architecture, engineering, or workmanship of any project. This information may be concurrent with, or superseded by other applicable documents, such as specifications and details. Contact Master Wall Inc. for the most current product information.

P. O. Box 397
Fortson, GA 31808
800-755-0825
Technical 800-760-2861
www.masterwall.com



Stucco Ad-Liquid



Stucco Ad-Liquid is an easy to use polymer modifier that is added directly to the stucco or

Stucco Additive

100% Acrylic

One Coat Stucco (OCS) mix to improve the overall quality of the material. Stucco Ad-Liquid improves stucco freeze/thaw stability, adhesion, cohesion, tensile strength, compressive strength and flexural strength. Helps to reduce shrinkage and drying cracks and, in most cases, fogging walls can be eliminated. Stucco Ad-Liquid is available in five-gallon (19L) pails and 55 gallon (208L) drums weighing 462 lbs (210 kg).

Approved For
Portland Cement Plaster
(Stucco)
One Coat Stucco (OCS)
Others approved in writing

Application Procedure

Job Conditions - Air and substrate temperature for application of *Stucco Ad-Liquid* must be 40°F (5°C) or higher and must remain 40°F (5°C) or higher for a minimum of 24 hours.

Temporary Protection – Provide temporary and permanent protection to prevent water entry behind the stucco.

Surface Preparation - Surface temperature must be above 40°F (5°C). Surface must be clean, dry, structurally sound and free of efflorescence, oil, grease, form release agents, paint and curing compounds.

Proportioning – Proportions will vary depending upon use. Reference Master Wall One Coat Stucco or Cemplaster Stucco specifications for warranted system proportions. In general, the product will achieve minimal properties such as improved crack resistance with levels as low as one quart (0.95L) per 280# (127 kg) of mixed stucco. Substituting *Stucco Ad-Liquid* for water in the stucco mix provides optimal performance. Vary proportions to meet specific project requirements or contact Master Wall for recommendations.

Mixing – Use non air entrained stucco mix. Slowly add *Stucco Ad-Liquid* to the mixture and mix for a short time (about 1 to 2 minutes) to avoid air entrapment.

Application

Apply stucco mix according to locally, regionally and nationally accepted practices to the specified thicknesses. When drying, *Stucco Ad-Liquid* forms a film or sheen that aids in the hydration of the stucco. Where approved locally, fogging the wall to aid in stucco curing may be eliminated.

For Professional Results

- Do not use with air entrained cement mixes or with air entraining admixtures.
- Do not use where air circulation is limited.
- Protect from extreme water exposure for a minimum of 24 hours.
- Fogging the wall is not recommended when *Stucco Ad-Liquid* is used.
- Do not use as a stucco surface primer or external bonding agent—use *Primecoat* or *Roller-flex* depending upon application.
- Do not over mix.

Clean Up

Tools and equipment can be cleaned with soapy water when the stucco mixture is wet.

Statistics

Suggested Levels (Varies)

One Coat Stucco (OCS): 3 quarts to 5 gallons (2.8-19 L) per mix

Stucco: 6 quarts to 5 gallons (5.6-19 L) per mix

Pail Weight: 42 lbs (19 kg)

Drum Weight: 462 lbs (210 kg)

Application Range: 40°-110°F (5°-43°C)

Shelf Life: 2 years



Information contained in this product data sheet conforms to the standard detail recommendations and specifications for the installation of Master Wall Inc. products and is presented in good faith. Master Wall Inc. assumes no liability, expressed or implied as to the architecture, engineering, or workmanship of any project. This information may be concurrent with, or superseded by other applicable documents, such as specifications and details. Contact Master Wall Inc. for the most current product information.

P. O. Box 397
Fortson, GA 31808

800-755-0825

Technical 800-760-2861

www.masterwall.com

Stucco is a time-proven wall cladding. However, there are many different variations, application techniques, curing and coloring conditions that the design professional must consider when specifying these systems.

This guideline specification is intended for use by the design/construction professional and any user of Master Wall products to assist in developing project specifications and to provide guidance on the application of the Master Wall One Coat Stucco System (OCS) to sound supporting construction.

System Description	Warranty Term	Comments
Acrylic Modified Stucco	7 year labor/material type	Improved Acrylic One Coat Stucco with Primer and Acrylic Finish

PART 1 GENERAL

1.01 SECTION INCLUDES

- A. Materials and installation of one coat stucco system.

1.02 RELATED SECTIONS

- A. Provide all materials, labor, and equipment to install the Field Applied and/or Panelized Master Wall Inc. One Coat Stucco System (OCS).
- B. Related Sections:
1. Concrete 03300
 2. Unit Masonry 04200
 3. Light Gauge Steel Framing 05400
 4. Sheathing 06100
 5. Sheet Metal Flashing and Trim 07620
 6. Sealants 07900
 7. Doors and Windows 08000

1.03 REFERENCED DOCUMENTS

- A. ASTM Standards:
1. C 847 Standard Specification for Metal Lath
 2. C 897 Aggregates for Job Mixed Portland Cement-Based Plaster
 3. C 926 Standard Specification for Application of Portland cement-Based Plaster
 4. C 1032 Standard Specification for Woven Wire Plaster Base
 5. C 1063 Installation of Lathing and furring for Portland Cement-Based Plaster

1.04 TERMS/DEFINITIONS

- A. Accessories – The closure trims, control joints metal reinforcement and mechanical fasteners used in the installation of stucco.
- B. Applicator – The contractor that applies the OCS.
- C. Building Expansion Joint – A joint through the entire building structure designed to accommodate structural movement.
- D. Control Joint – a joint in the OCS designed to reduce and control thermal and shrinkage cracking.
- E. Designer – The person or firm that is responsible to create the plans and specifications for the entire project.
- F. Finish Coat – An acrylic based, factory mixed decorative and protective coating that is applied to the base coat.



- G. Mechanical Fastener – Corrosion-resistant fastener intended for use with stucco.
- H. Metal Reinforcement – Various forms of metal used to reinforce and support the stucco.
- I. OCS – One Coat Stucco, a cementitious material consisting of Portland cement, fibers and proprietary components.
- J. Sheathing – A substrate in a sheet form.
- K. Substrate – The material to which the OCS is attached.
- L. Trims – Specially manufactured products designed to terminate the OCS.

1.05 DESIGN REQUIREMENTS

- A. Structural
 - 1. Design for maximum allowable system deflection, normal to the plane of the wall, of L/360.
 - 2. Design for wind load in conformance with code requirements. Also consult applicable code compliance report.
- B. Moisture Control
 - 1. Prevent the accumulation of water into or behind the OCS, either by condensation or leakage into the wall construction, in the design and detailing of the wall assembly.
 - a. Provide corrosion resistant flashing to direct water to the exterior where it is likely to penetrate components in the wall assembly, including, above window and door heads, beneath window and door sills, at roof/wall intersections, decks, abutments of lower walls with higher walls, above projecting features, and at the base of the wall.
 - b. Wall System Design – design wall to eliminate vapor condensation within the wall assembly.
 - c. Weather Resistant Barrier – Provide a barrier over framed construction consisting of a minimum of two-layers asphalt felt meeting ASTM D-226, Type 1, Grade D or building code-approved alternate. Verify requirements with local building code authority.
 - d. Protect sills of rough openings with water resistant barrier or “peel and stick” type membranes recognized by local codes. Where casing bead is used back-to-back at expansion joints back joints with barrier membrane. Refer to Master Wall details.
- C. Grade Condition
 - 1. Keep OCS a minimum of 6” (152 mm) above grade in framed construction.
- D. Expansion Joints
 - 1. Provide expansion joints where directed by the design professional. Common locations include the following:
 - A. Where building movement is anticipated.
 - B. At dissimilar substrates.
 - C. At floor lines in certain wood framed constructions.
 - D. Where the stucco meets dissimilar materials.
 - 2. Expansion joint design depends upon the anticipated movement. Master Wall suggests the following minimum sizes, subject to design acceptance: Windows/Doors – 3/8” (9.5 mm), Building Expansion/Dissimilar Substrates & Materials – 1/2” (13 mm), Floor Line (shrinkage) – 3/4” (19 mm).



Section 09 24 23

Corporate • P.O. Box 397 • Fortson • Georgia • 31808 • 800-755-0825 • FAX 706-569-6704

Technical • 800-760-2861 • FAX 734-433-0930

- E. Control Joints
 - 1. Provide control joints where directed by the design professional. Common locations include the following:
 - A. To limit cracking in the system at a maximum area of 144 ft² (13.4 m²).
 - B. Length to width ratio should not be more than 2.5:1.
 - C. Off the corners of window/door heads or jamb.
 - D. At dissimilar substrates.
 - 2. Increase joint requirements where thicker stucco or special structural conditions exist.
 - 3. Typically control joints are tied to the metal lath, which is cut to make two discontinuous slabs.
 - 4. When OCS is bonded to a solid substrate such as concrete or masonry the control joint requirements may be revised. Control joints may be aligned with any control joints in the plaster base.
- F. Provide appropriate sealant at stucco terminations using a sealant designed for cement/stucco use (sealant trades, Section 07920).
- G. Indicate location of joints, accessories and accessory type on architectural drawings.
- H. Fire Protection
 - 1. Refer to manufacturer's applicable code compliance report for other limitations and fire-resistive assemblies that may apply.
- I. Solid Substrates
 - 1. Provide surface plane tolerance not to exceed ¼ inch in 10 feet (6.4 mm in 3.05 m).
 - 2. Concrete—prevent the use of form oil, curing compounds or other bond breakers that inhibit bond to the surface or provide for their removal.
 - 3. Concrete Masonry—provide open texture concrete masonry units with flush joints.
 - 4. Brick – soft to medium fired, porous to provide acceptable bond for stucco.

1.06 PERFORMANCE REQUIREMENTS

A. System Performance

The OCS shall conform to the following minimum standards:

ASTM Standard	Description	Results
C67	Freeze/Thaw	Pass ICBO ACII Criteria
C109	Compressive Strength	3000 psi
E84	Surface Burning	Flame Spread=0, Smoke Developed=0
E119	Fire Rating	One Hour
E330	Transverse Load	+/- 150 psf Ultimate. Allowable varies by Code
G26	Accelerated Weathering	Pass 2000 Hours

1.07 SUBMITTALS

- A. The Applicator shall submit a list of completed projects of like size and complexity.
- B. The Applicator shall submit a certificate of training indicating that they have been given instructions on the proper installation of the OCS.
- C. The Applicator shall submit Manufacturer's current literature, brochures, specifications, and details.
- D. The Applicator shall submit sufficient samples of each finish texture and color selected. The samples shall be prepared with the same tools and techniques required for the actual project. Color and texture should be approved based on the job site mock-up samples.
- E. The Applicator shall provide any shop drawings that may be applicable to the project for approval by the project architect.



1.08 DELIVERY, STORAGE AND HANDLING

- A. Deliver all materials in original unopened packages with labels intact. Verify all quantities, colors, and textures against bill of lading.
- B. Store all materials protected from direct exposure to weather conditions and at temperatures not less than 40° F (5° C) or greater than 110° F (43° C).
- C. Material safety data sheets (MSDS) shall be supplied for the components of the OCS and be available at the job site.

1.09 JOB CONDITIONS

- A. Ambient air temperatures shall be 40° F (5° C) or greater and rising at the time of installation of the Master Wall Inc. products and shall remain at 40° F (5° C) or greater for at least 24 hours after application.
- B. Provide supplemental heat and protection as required when the temperature and conditions are not in accordance with installation requirements. Sufficient ventilation and time shall be provided to ensure that materials have sufficiently dried prior to removing supplemental heat.
- C. Adequate protection shall be provided to prevent weather conditions (humidity, temperature, and precipitation) from having an affect on the curing or drying time of **Master Wall Inc.** materials.
- D. Adjacent materials and the OCS shall be protected during installation and while curing from weather and shall be protected from site damage.
- E. Coordinate installation of the OCS with related work specified in other sections to ensure that the wall assembly is protected to prevent water from getting behind the system. The cap flashing shall be installed as soon as possible after the finish coat has been applied. When this is not possible, temporary protection shall be provided immediately in this area.
- F. All sealants shall be installed in a timely manner. Protect open joints from water intrusion during construction with backer rod, or temporary covering, until permanently sealed.
- G. Sufficient manpower and equipment shall be employed to ensure a continuous operation, free of cold joints, scaffolding lines, and texture variations, etc.
- H. Solid substrates shall be allowed to cure long enough to support the stucco work. Minimum 28 days for concrete and masonry units.

1.10 REPAIR AND MAINTENANCE

- A. Refer to Master Wall Inc. specific repair and maintenance procedures.

1.11 LIMITED MATERIALS WARRANTY

- A. A Limited Materials Warranty shall be issued upon the receipt of a properly completed warranty request form.



PART 2 PRODUCTS

2.01 MANUFACTURERS

- A. **Master Wall Inc.**
- B. Provide one coat stucco system from single source manufacturer.

2.02 BONDING AGENT

- A. **BA57**-water based acrylic resin bonding agent for brush or roller application to prepared masonry surfaces.

2.03 MOISTURE BARRIER *(supplied by others)*

- A. Minimum 14-lb/100 ft² (0.683 kg/m²) vapor permeable asphalt saturated felt in compliance with ASTM D 226.
- B. Other weather barrier meeting the local building code criteria.

2.04 LATH *(supplied by others; select one depending on type construction)*

- A. Minimum No. 20 gauge 1 inch (25 mm) self-furred galvanized steel woven wire fabric in compliance with ASTM C 1032.
- B. Minimum 1.75 lb./yd² (0.98 kg/m²) or 2.5 lb./yd² (1.4 kg/m²) self-furred galvanized steel diamond mesh metal lath in compliance with ASTM C 847.

2.05 MECHANICAL FASTENERS *(by others)*

- A. Appropriate non-corroding fasteners, depending on the type framing or substrate:
 - 1. Wood Framing—minimum 11 gauge, 7/16 inch (11 mm) diameter head galvanized roofing nails with minimum ¾ inch (19mm) penetration into studs or minimum #8 Type S wafer head fully threaded corrosion resistant screws with minimum ¾ inch (19 mm) penetration into studs.
 - 2. Steel Framing—minimum #8 Type S or S-12 wafer head fully threaded corrosion resistant screws with minimum 3/8-inch (9.5 mm) penetration into studs.
 - 3. Concrete or Masonry—minimum # 8 wafer head fully threaded corrosion resistant screws for masonry with minimum 1 inch (25 mm) penetration into substrate.
- B. Tie Wire—18 gauge galvanized and annealed low-carbon steel in compliance with ASTM A 641 with Class I coating.

2.06 ACCESSORIES *(by others)*

- A. Weep screed, casing bead, corner bead, cornerite, corner lath, expansion and control joint accessories. All accessories shall meet the requirements of ASTM C 1063 and its referenced documents:
 - 1. PVC plastic in compliance with ASTM D 1784, cell classification 13244C.
 - 2. Zinc in compliance with ASTM B 69.
 - 3. Galvanized metal in compliance with ASTM A 653 with G60 coating.
- B. All accessories shall have perforated or expanded flanges and shall be designed with grounds for the specified thickness of stucco.



2.07 JOB MIXED INGREDIENTS

- A. Water: Clear, clean and potable without any foreign matter in the solution that may affect the color and setting qualities of the cement, adhesive, base or finish coat.
- B. Sand: Clean, well graded sand free of deleterious materials in compliance with ASTM C 897.
- C. Cement: Type I or I-II Portland cement meeting ASTM C-150.
- D. Stucco Admixture
 - 1. **Stucco Ad Liquid**—water based acrylic resin admixture for Master Wall One Coat Stucco.

2.08 STUCCO (select one)

- A. **Master Wall One Coat Stucco**—factory proportioned, fiber reinforced (or non-fibered) Portland cement based stucco for trowel or pump application, field mixed with graded sand (ASTM C 897) and water.
- B. **Master Wall Ready One Coat Stucco**— factory proportioned, fiber reinforced (or non-fibered) Portland cement based stucco for trowel or pump application, field mixed with water.

2.09 PRIMER

- A. **Master Wall Primecoat**: acrylic-based tinted primer.

2.10 FINISH COAT

- A. **Superior Finish**: Master Wall Inc.'s Superior Finishes are acrylic-based wall coatings available in a variety of colors and textures. The following textures are available:
 - 1. Perfect - riled texture
 - 2. Spray – sand type texture
 - 3. R-Coarse – coarse riled texture
 - 4. Desert Sand – coarse sand texture
 - 5. Refinish – Fine texture used to create numerous finishes
 - 6. Superior Stone and Aggrestone Finish – clear acrylic matrix filled with colored ceramic beads
- A. **Superior Elastomeric or Elastomeric Plus Finish (optional)**: Master Wall Inc.'s Superior Finishes using elastomeric polymers to bridge minor cracking. The following textures are available:
 - 1. Perfect - riled texture
 - 2. Spray – sand type texture
 - 3. R-Coarse – coarse riled texture
 - 4. Desert Sand – coarse sand texture
 - 5. Refinish – Fine texture used to create numerous finishes

(Note: The above textures excluding Superior Stone and Aggrestone Finishes are also available in the Aggre-flex Superior Silicone Coat product line. Aggre-flex Superior Silicone Coat combines acrylic and the siloxane polymers to provide the maximum resistance to moisture.)



2.11 MIXING

- A. **BA57 & Stucco Ad Liquid:** Shake sealed container or mix before use to a homogeneous consistency.
- B. **Acrylic Modified Master Wall One Coat Stucco:** Mix 200 lbs. (90 kg) of sand to an 80 lb (36 kg) bag of Master Wall One Coat Stucco. Add pre-blended dry mix to 3 quarts (2.8 L) *Stucco Ad Liquid* and 4-6 gallons (15-23 L) of clean potable water. Mix with paddle type mortar mixer to a uniform consistency. Avoid retempering. Keep mix ratio consistent and mix each batch separately. Do not exceed maximum amount of water in mix ratio.
- C. **Acrylic Modified Master Wall Ready One Coat Stucco:** Each bag of Ready OCS is mixed with 1 quart (.95 L) of *Stucco Ad Liquid* and clean, potable water. Using a clean mixer, first add 1/2 to 2/3 the water/*Stucco Ad Liquid* mix required, 1 bag Ready OCS, then the rest of the water to achieve the desired workability. Mix materials for 3 to 5 minutes after all materials are in the mixer. Total water/*Stucco Ad Liquid* content can vary between 1 to 1.5 gallons (3.8-5.7 L).
- D. **Superior Finishes:** Mix the finish coat with a Wind-lock B-MTW using a 1/2", 400-500 RPM drill motor. Small amounts of water can be added for workability. Mix until reaching a uniform consistency. (It is important that the same amount of water be added to each pail to ensure a consistent color.)
- E. Additives shall not be added to Master Wall Inc.'s materials unless written approval has been received from Master Wall Inc.
- F. Mix only as much material as can readily be used.
- G. Do not use anti-freeze compounds or other additives.

PART 3 EXECUTION

3.01 EXAMINATION

- A. Prior to installation of the OCS, the contractor shall verify that the substrate and water barrier:
 1. Is of a type listed in this specification.
 2. Is installed to shed water in accordance with this specification.
 3. Is flat within 6.4 mm (1/4 in) in a 3 m (10 ft) radius.
 4. Is sound, dry, connections are tight, has no surface voids, projections or other conditions that may interfere with the OCS installation or performance.
- B. Prior to the installation of the OCS, the architect or general contractor shall insure that all needed flashings and other waterproofing details have been completed, if such completion is required prior to the coatings application. Additionally, the Contractor shall ensure that:
 1. Metal roof flashing has been installed in accordance with Asphalt Roofing Manufacturers Association (ARMA) Standards.
 2. Openings are flashed in accordance with the OCS Installation Details or as otherwise necessary to prevent water penetration.
 3. Chimneys, Balconies, and Decks have been properly flashed.
 4. Windows, Doors, etc. are installed and flashed per manufacturer's requirements and the OCS Installation Details.
- C. Prior to the installation of the OCS, the contractor shall notify the general contractor, and/or architect, and/or owner of all discrepancies.

3.02 PREPARATION

- A. The OCS materials shall be protected by permanent or temporary means from inclement weather and other sources of damage prior to, during, and following application until completely dry.
- B. Protect adjoining work and property during OCS installation.
- C. The substrate shall be prepared as to be free of foreign materials, such as, oil, dust, dirt, form release agents, efflorescence, paint, wax, water repellents, moisture, frost and any other condition that inhibit adhesion.



3.03 INSTALLATION

- A. The system shall be installed in accordance with the current Master Wall Inc. OCS Application Instructions.
- B. The overall minimum stucco scratch and brown coat thickness shall be sufficient to fully embed the reinforcing mesh.
- C. Sealant shall not be applied directly to textured finishes.

3.04 FIELD QUALITY CONTROL

- A. The contractor shall be responsible for the proper application of the OCS materials.
- B. Master Wall Inc. assumes no responsibility for on-site inspections or application of its products.
- C. If required, the contractor shall certify in writing the quality of work performed relative to the substrate system, details, installation procedures, workmanship and as to the specific products used.
- D. If required, the sealant contractor shall certify in writing that the sealant application is in accordance with the sealant manufacturer's and Master Wall Inc.'s recommendations.

3.05 CLEANING

- A. All excess OCS materials shall be removed from the job site by the contractor in accordance with contract provisions and as required by applicable law.
- B. All surrounding areas, where the OCS has been installed, shall be left free of debris and foreign substances resulting from the contractor's work.

3.06 PROTECTION

- A. The OCS shall be protected from inclement weather and other sources of damage until dry and permanent protection in the form of flashings, sealants, etc. are installed.

End of Specification

Disclaimer

This Specification is published for general informational purposes only and is not intended to imply that these are the only materials, procedures, or methods, which are available or suitable. Materials, procedures, or methods may vary according to the particular circumstances, local building code requirements, design conditions, or statutory and regulatory requirements. While the information in this specification is believed to be accurate and reliable, it is presented without guarantee or responsibility on the part of Master Wall Inc.

System Details & Descriptions

Item	Description	Warranty Term*	✓
Weather Resistive Barriers (WRB) and Drainage Spacers (DRS)			
WRB01	2- ASTM D226 Asphalt Felt (minimum over sheathing)	0	<input checked="" type="checkbox"/>
WRB02	Tyvek® StuccoWrap® or similar with 1-layer of ASTM D226 Asphalt Felt (over sheathing)	0	<input type="checkbox"/>
WRB03	Master Wall Rollershield with 1-layer of ASTM D226 Asphalt Felt (over sheathing)	5	<input type="checkbox"/>
WRB04	Master Wall Rollershield (over concrete or masonry, lath required)	5	<input type="checkbox"/>
DRS00	No Spacer	0	<input checked="" type="checkbox"/>
DRS01	Drainage Mat: Colbond, Keene, Benjamin Obdyke	0	<input type="checkbox"/>
DRS02	Rainscreen: Cosella-Dörken Products, Inc. Delta® -Dry, Delta® -Dry Plus	1	<input type="checkbox"/>
OCS Fiberstucco (OCS)			
OCS01	Master Wall OCS Fiberstucco with 17 ga. woven wire fabric reinforcement, 3/8" thick	2	<input type="checkbox"/>
OCS02	Master Wall OCS Fiberstucco direct to Masonry/Concrete (no Rollershield), 3/8"-1/2" thick	3	<input checked="" type="checkbox"/>
OCS03	Master Wall OCS Fiberstucco with 2.5#/sy self-furring reinforcement, 1/2" thick	3	<input type="checkbox"/>
OCS04	Master Wall OCS Fiberstucco with 3.4#/sy self-furring reinforcement, 3/4" thick	4	<input type="checkbox"/>
Stucco Additives (SA)			
SA00	None	0	<input type="checkbox"/>
SA01	Master Wall Stucco Ad Liquid, 3 qt per mix of OCS Concentrate, 1 qt per bag of Ready OCS	1	<input checked="" type="checkbox"/>
SA02	Master Wall Stucco Ad Liquid, 2 gal per mix of OCS Concentrate, 3 quarts per bag of Ready OCS	2	<input type="checkbox"/>
SA03	Master Wall Stucco Ad Liquid, 5 gal per mix of OCS Concentrate, 1-1/2 gal per bag of Ready OCS	3	<input type="checkbox"/>
Leveling Base Coats (LBC)			
LBC00	None	0	<input checked="" type="checkbox"/>
LBC01	F&M, F&M Plus, MBB or Guardian Skim Coat	1	<input type="checkbox"/>
LBC02	F&M, F&M Plus, MBB or Guardian Skim Coat with Master Wall Standard Reinforcing Mesh	2	<input type="checkbox"/>
Primers (PRIME), Finish Additives (FA), Finish Options (FIN)			
PRIME00	No Primer	0	<input type="checkbox"/>
PRIME01	Primecoat or Sanded Primecoat tinted primer	1	<input checked="" type="checkbox"/>
FIN01	Superior Finish	1	<input checked="" type="checkbox"/>
FA01	Excel Additive (to any finish)	0.5	<input type="checkbox"/>
FA02	Silicone Coat (to any finish)	0.5	<input type="checkbox"/>

Example of basic system: WRB01 (0) + OCS03 (3) with PRIME01 (1) and FIN01 (1) = 5 year warranty

*minimum requirement for warranty: OCS and finish

These drawings relay the conceptual conditions of Master Wall Systems and are not the construction drawings. Ultimately the design and detailing of an entire wall system is the responsibility of a professional. These details will guide the design professional in the use of Master Wall Products. Master Wall disclaims design, warranty or construction intent or responsibility.

Conceptual Details

Corporate • P.O. Box 397 • Fortson • Georgia • 31808 • 800-755-0825 • FAX 706-569-6704

Technical • 800-760-2861 • FAX 734-433-0930

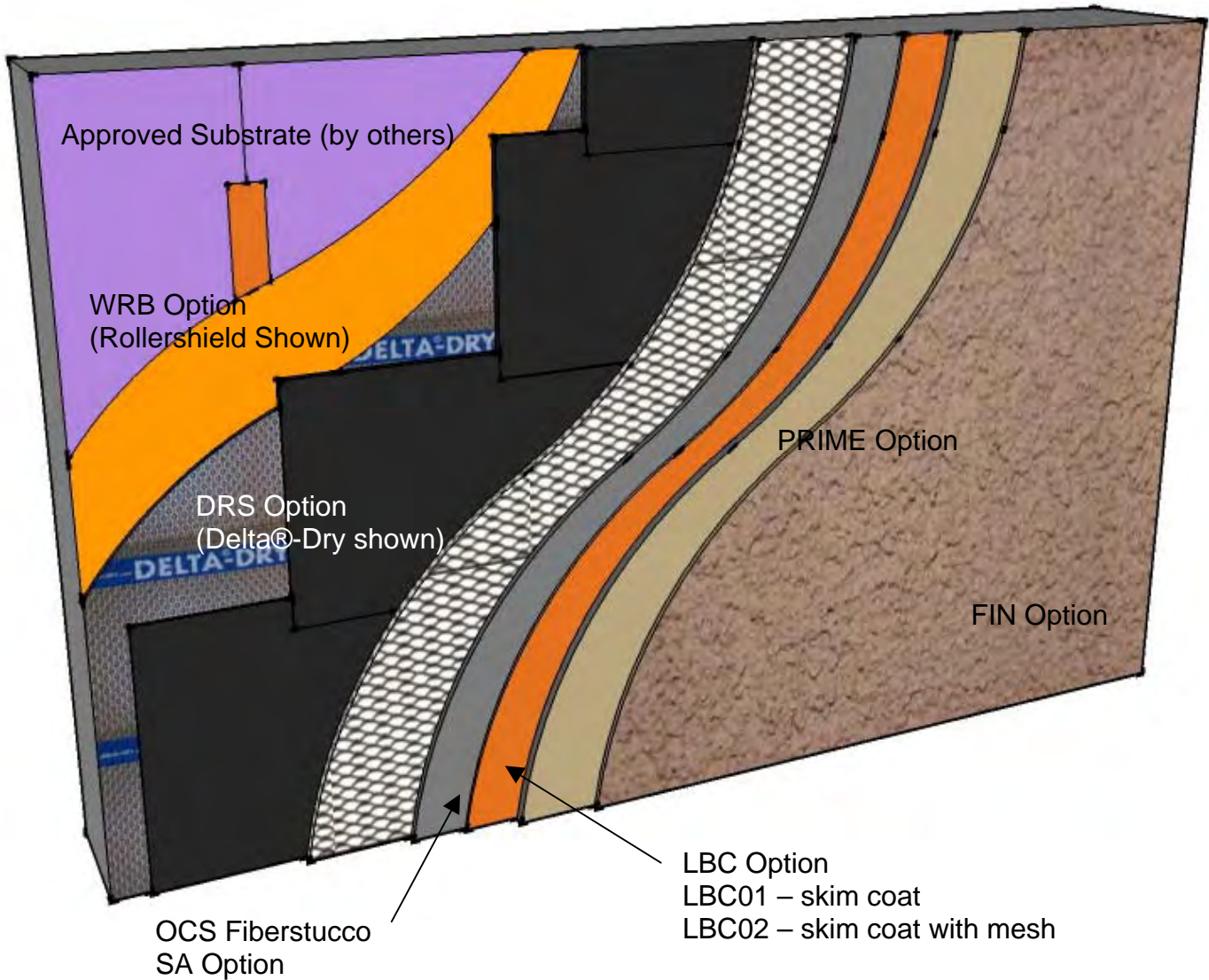

OCS01, OCS03, OCS04 Cross-Section with options

These drawings relay the conceptual conditions of Master Wall Systems and are not the construction drawings. Ultimately the design and detailing of an entire wall system is the responsibility of a professional. These details will guide the design professional in the use of Master Wall Products. Master Wall disclaims design, warranty or construction intent or responsibility.

Conceptual Details

Corporate • P.O. Box 397 • Fortson • Georgia • 31808 • 800-755-0825 • FAX 706-569-6704

Technical • 800-760-2861 • FAX 734-433-0930

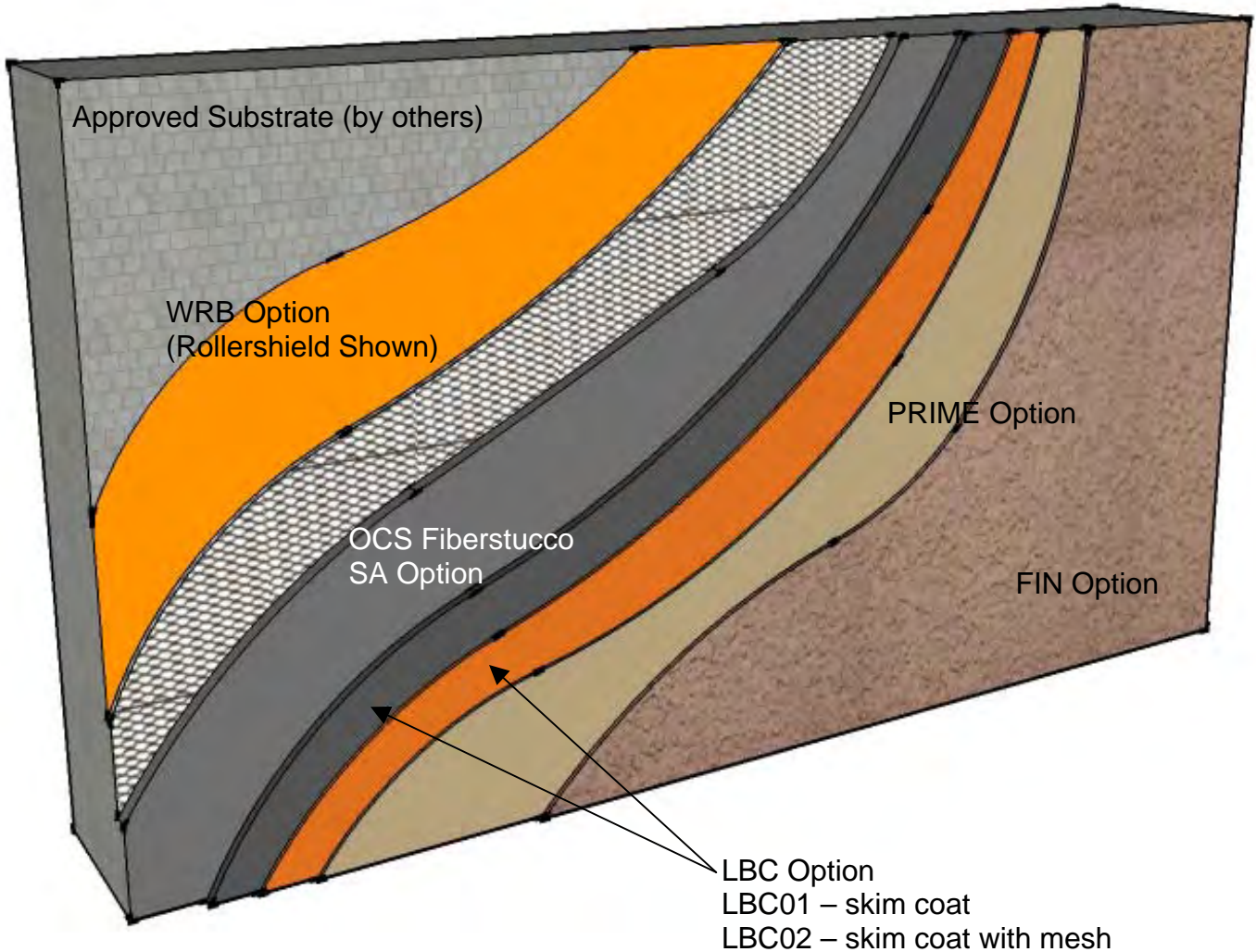

OCS01, OCS03, OCS04 Cross-Section with options

These drawings relay the conceptual conditions of Master Wall Systems and are not the construction drawings. Ultimately the design and detailing of an entire wall system is the responsibility of a professional. These details will guide the design professional in the use of Master Wall Products. Master Wall disclaims design, warranty or construction intent or responsibility.

Conceptual Details

Corporate • P.O. Box 397 • Fortson • Georgia • 31808 • 800-755-0825 • FAX 706-569-6704

Technical • 800-760-2861 • FAX 734-433-0930

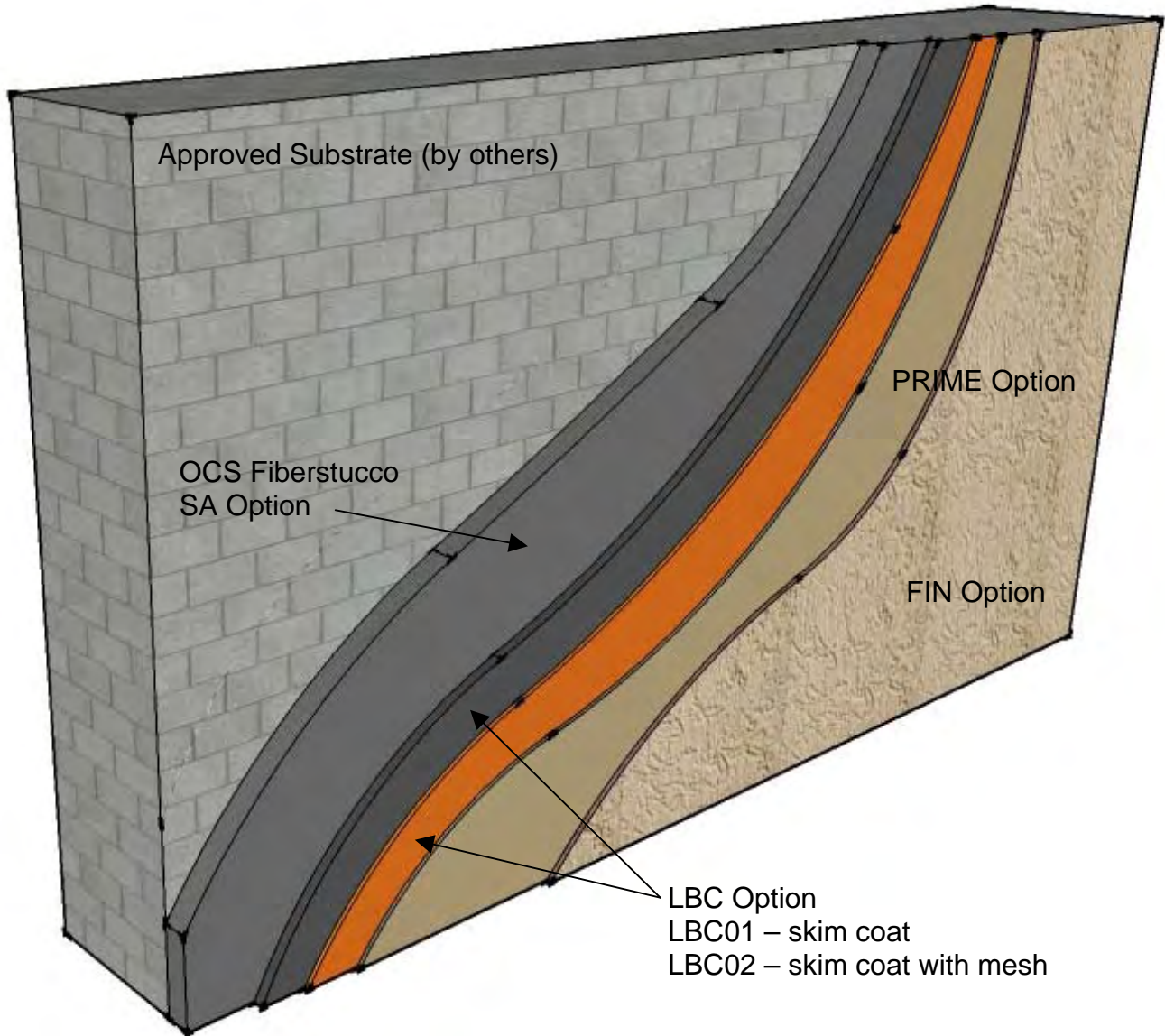

OCS02 Cross-Section with options

These drawings relay the conceptual conditions of Master Wall Systems and are not the construction drawings. Ultimately the design and detailing of an entire wall system is the responsibility of a professional. These details will guide the design professional in the use of Master Wall Products. Master Wall disclaims design, warranty or construction intent or responsibility.

Conceptual Details

Corporate • P.O. Box 397 • Fortson • Georgia • 31808 • 800-755-0825 • FAX 706-569-6704

Technical • 800-760-2861 • FAX 734-433-0930

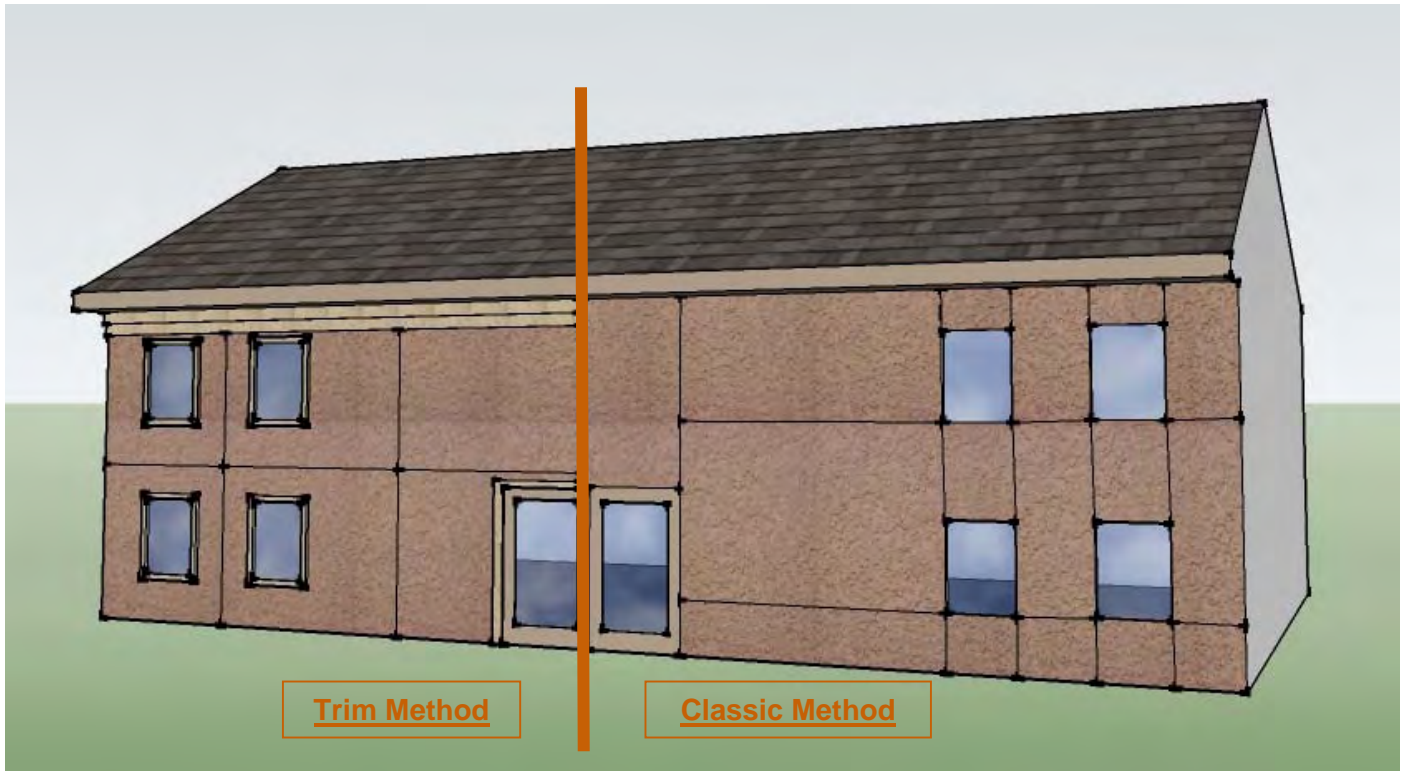

Notes:

Control joints are required and should be located by the designer at the following locations on the construction documents:

- 144 sf (13.4 sm) is the maximum overall area
- One dimension shall not exceed 2-1/2 times the other dimension
- At all dissimilar substrate/sheathing transitions.
- Possibly off corners of windows/doors.
- Increase control joint requirements where thicker stucco or special structural conditions exist.

Control Joint Study (General)

These drawings relay the conceptual conditions of Master Wall Systems and are not the construction drawings. Ultimately the design and detailing of an entire wall system is the responsibility of a professional. These details will guide the design professional in the use of Master Wall Products. Master Wall disclaims design, warranty or construction intent or responsibility.

Conceptual Details

Corporate • P.O. Box 397 • Fortson • Georgia • 31808 • 800-755-0825 • FAX 706-569-6704

Technical • 800-760-2861 • FAX 734-433-0930

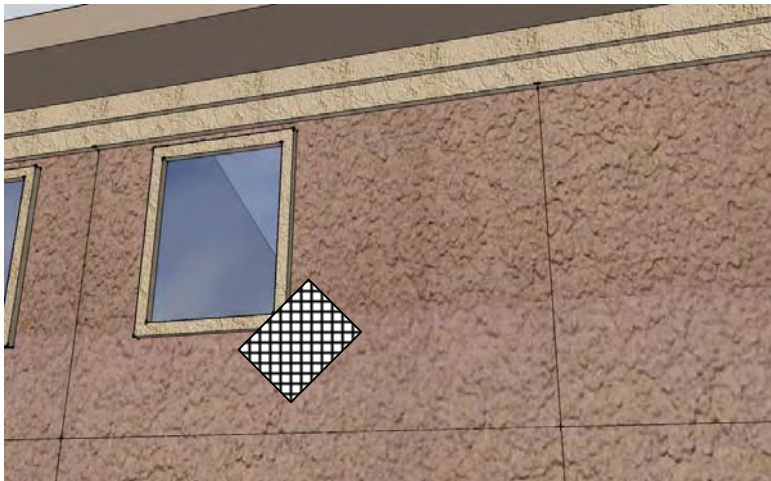
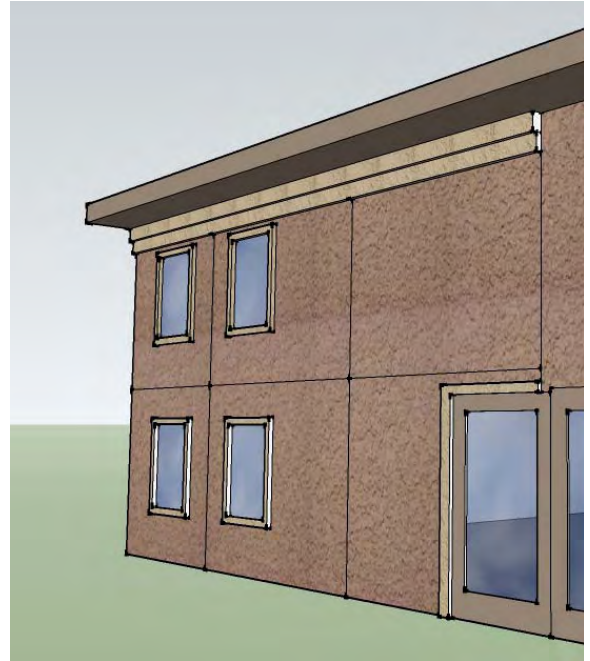
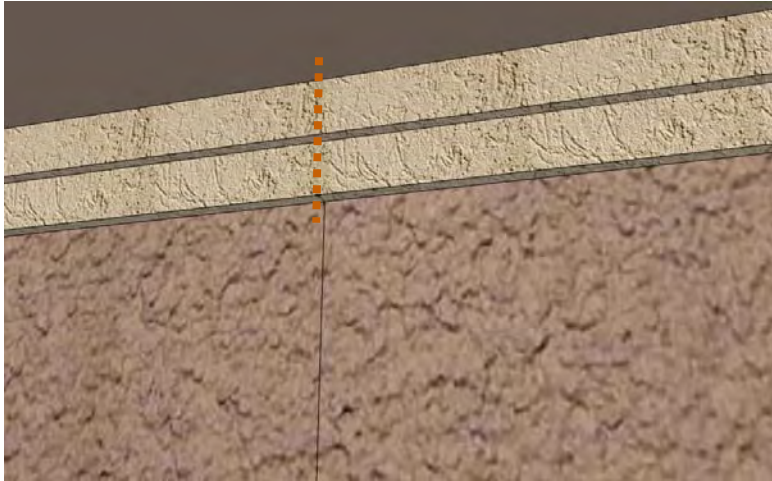

Trim Method Notes

- ❑ If trim is planned it's usually best to avoid running the control joints through them.
- ❑ Evaluate floor line conditions and place either a control or expansion joint.
- ❑ If large foam trims are used, plan on adding an expansion joint in the trim if the control joint continues behind it.
- ❑ Use butterfly lath reinforcement at corners.

Control Joint Study (Trim Method)

These drawings relay the conceptual conditions of Master Wall Systems and are not the construction drawings. Ultimately the design and detailing of an entire wall system is the responsibility of a professional. These details will guide the design professional in the use of Master Wall Products. Master Wall disclaims design, warranty or construction intent or responsibility.

Conceptual Details

Corporate • P.O. Box 397 • Fortson • Georgia • 31808 • 800-755-0825 • FAX 706-569-6704

Technical • 800-760-2861 • FAX 734-433-0930

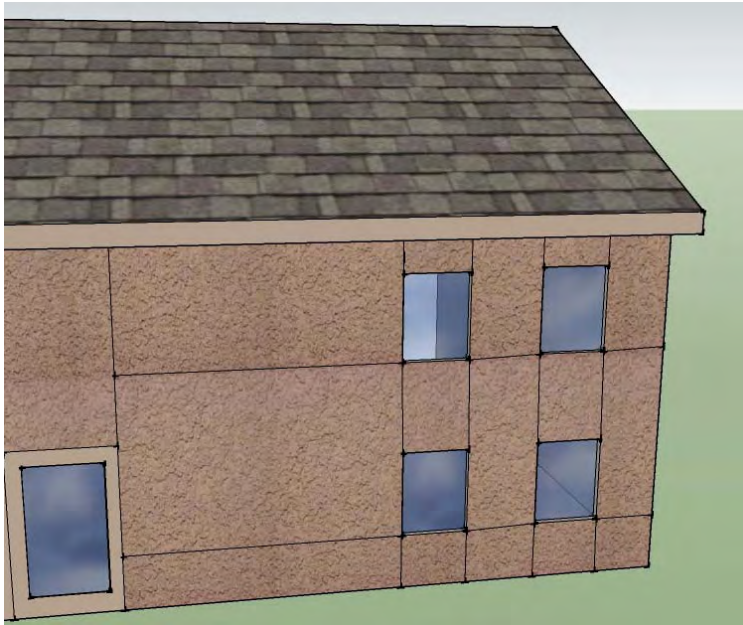

Classic Method Notes

- ❑ The classic method uses the window and door openings as part of the control joint process
- ❑ Evaluate floor line conditions and place either a control or expansion joint if needed, otherwise follow the general guidelines.
- ❑ Generally foam trims aren't used with this aesthetic condition.
- ❑ Do not use butterfly lath reinforcement at corners.

Control Joint Study (Classic Method)

These drawings relay the conceptual conditions of Master Wall Systems and are not the construction drawings. Ultimately the design and detailing of an entire wall system is the responsibility of a professional. These details will guide the design professional in the use of Master Wall Products. Master Wall disclaims design, warranty or construction intent or responsibility.

Conceptual Details

Corporate • P.O. Box 397 • Fortson • Georgia • 31808 • 800-755-0825 • FAX 706-569-6704

Technical • 800-760-2861 • FAX 734-433-0930

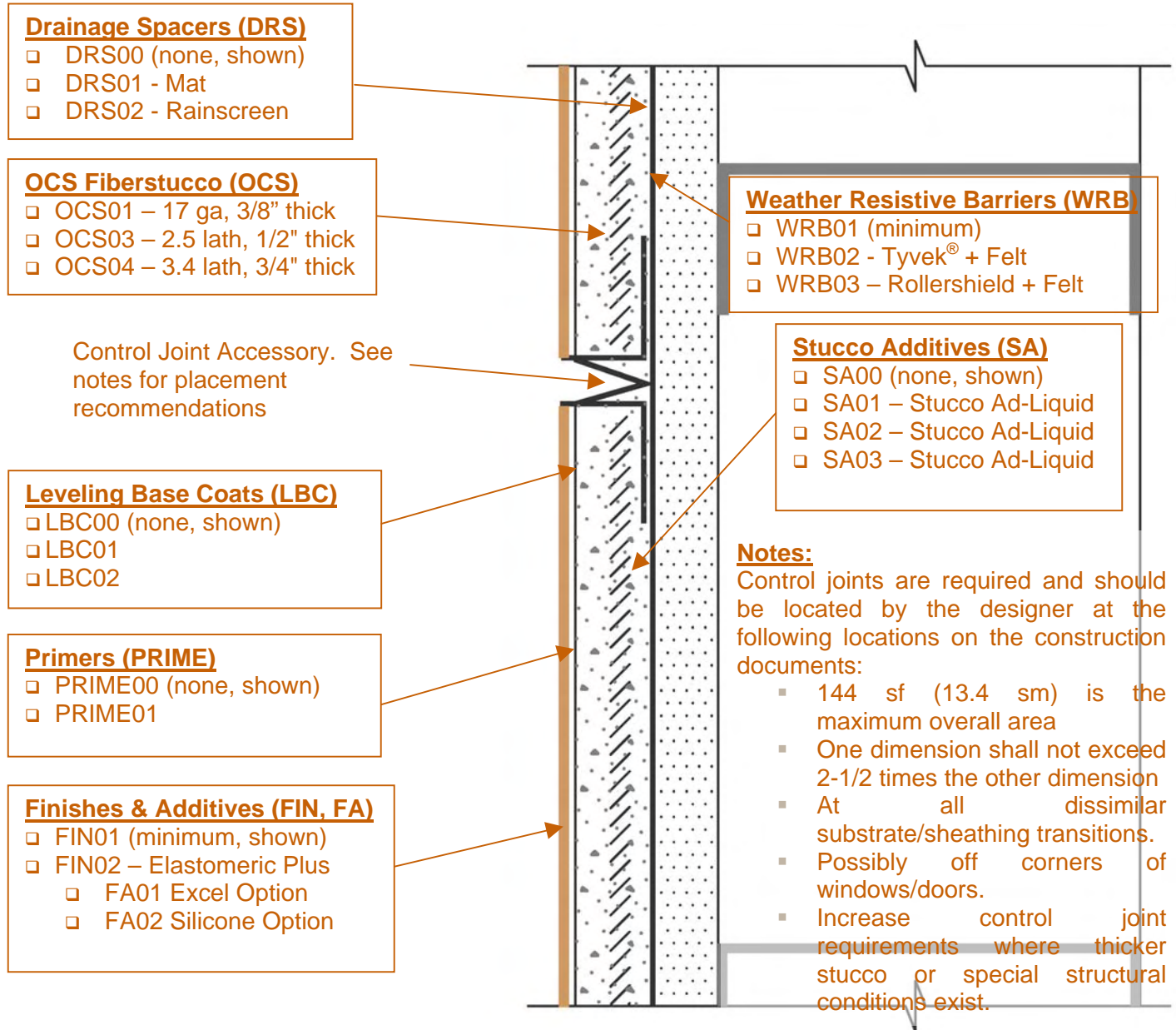

OCSFS-01 Cross-Section

These drawings relay the conceptual conditions of Master Wall Systems and are not the construction drawings. Ultimately the design and detailing of an entire wall system is the responsibility of a professional. These details will guide the design professional in the use of Master Wall Products. Master Wall disclaims design, warranty or construction intent or responsibility.

Conceptual Details

Corporate • P.O. Box 397 • Fortson • Georgia • 31808 • 800-755-0825 • FAX 706-569-6704

Technical • 800-760-2861 • FAX 734-433-0930

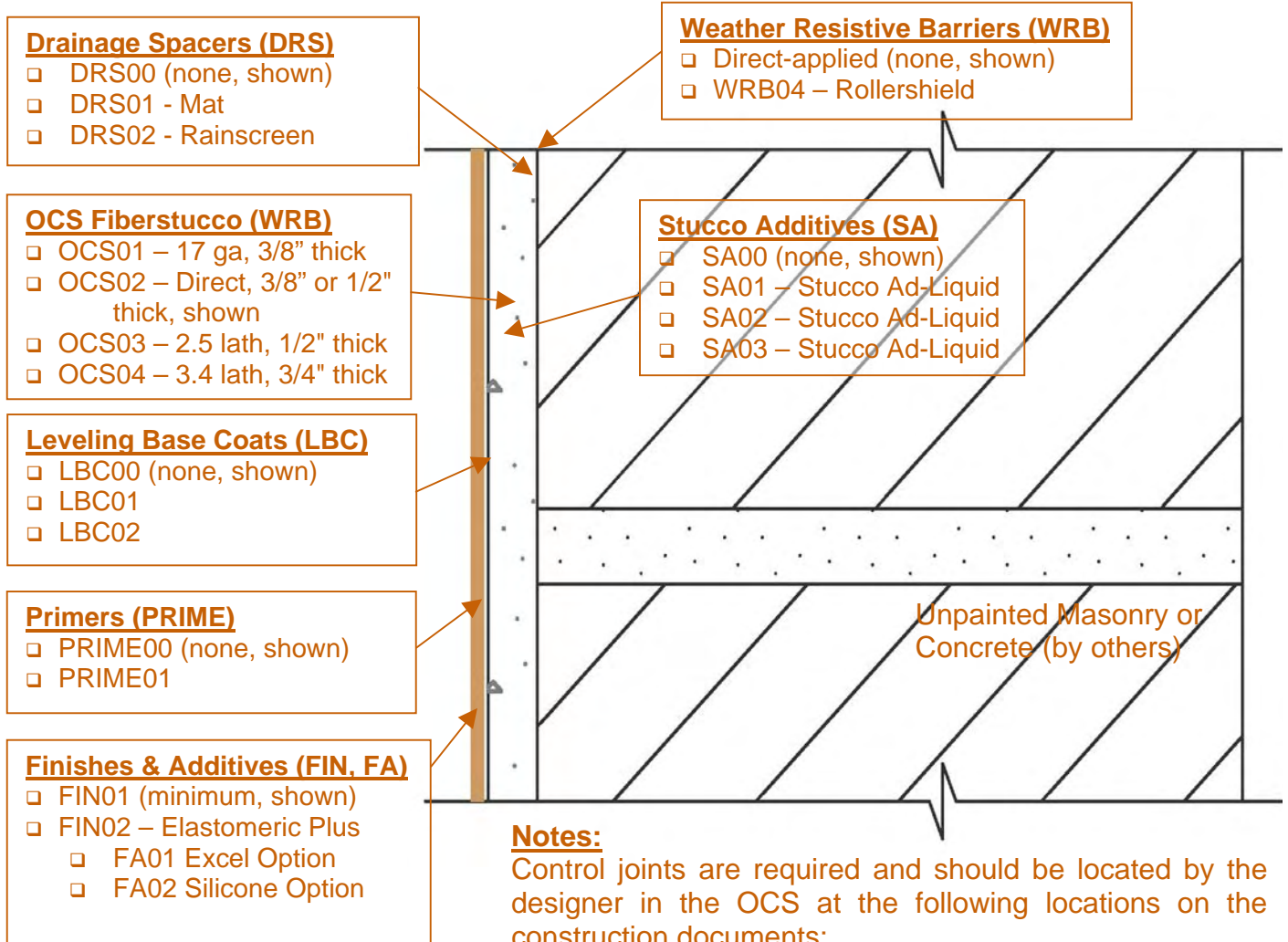

OCSFS-02 Cross-Section

These drawings relay the conceptual conditions of Master Wall Systems and are not the construction drawings. Ultimately the design and detailing of an entire wall system is the responsibility of a professional. These details will guide the design professional in the use of Master Wall Products. Master Wall disclaims design, warranty or construction intent or responsibility.

Conceptual Details

Corporate • P.O. Box 397 • Fortson • Georgia • 31808 • 800-755-0825 • FAX 706-569-6704

Technical • 800-760-2861 • FAX 734-433-0930

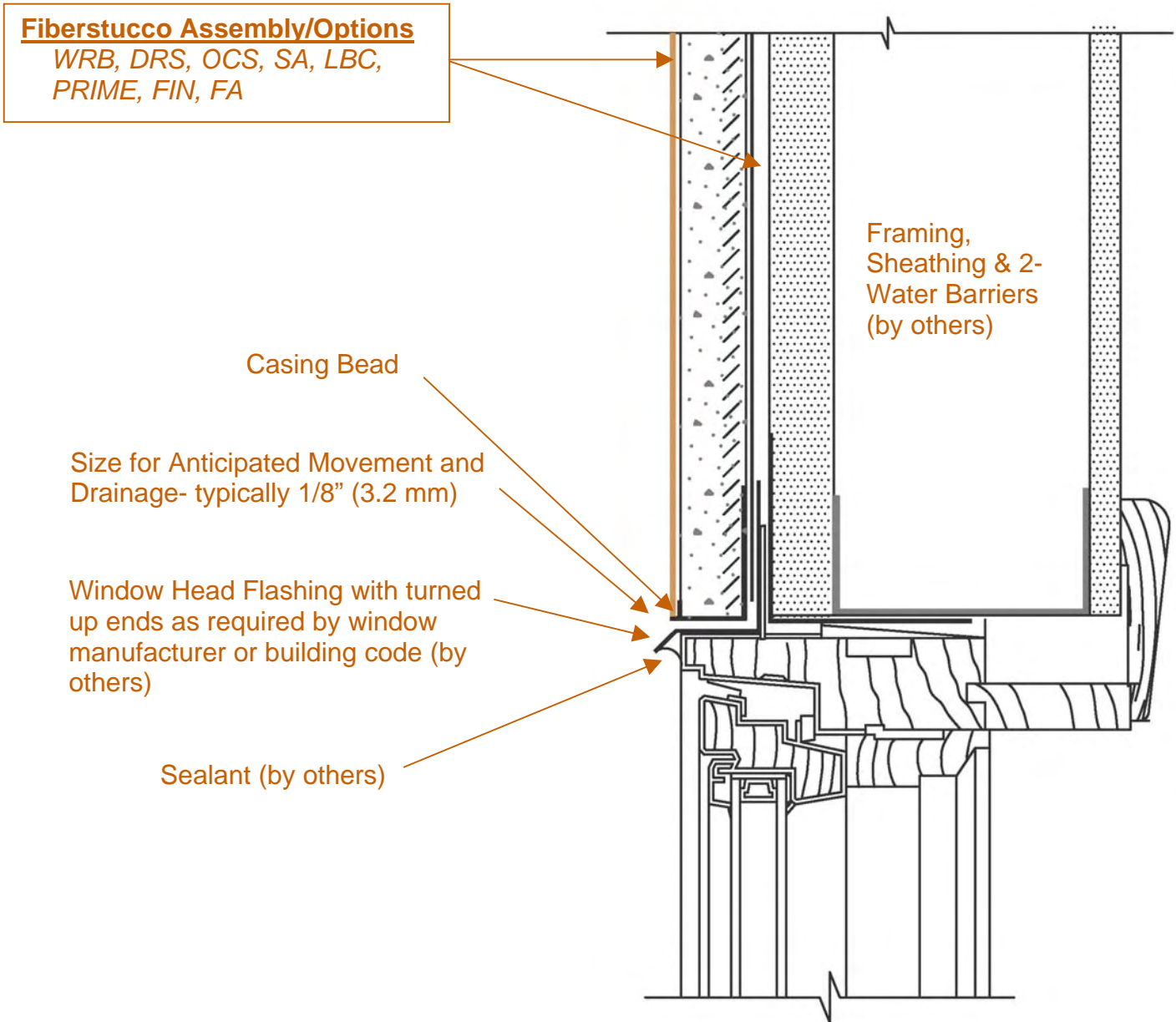

OCSFS-03 Clad Window Head

These drawings relay the conceptual conditions of Master Wall Systems and are not the construction drawings. Ultimately the design and detailing of an entire wall system is the responsibility of a professional. These details will guide the design professional in the use of Master Wall Products. Master Wall disclaims design, warranty or construction intent or responsibility.

Conceptual Details

Corporate • P.O. Box 397 • Fortson • Georgia • 31808 • 800-755-0825 • FAX 706-569-6704

Technical • 800-760-2861 • FAX 734-433-0930

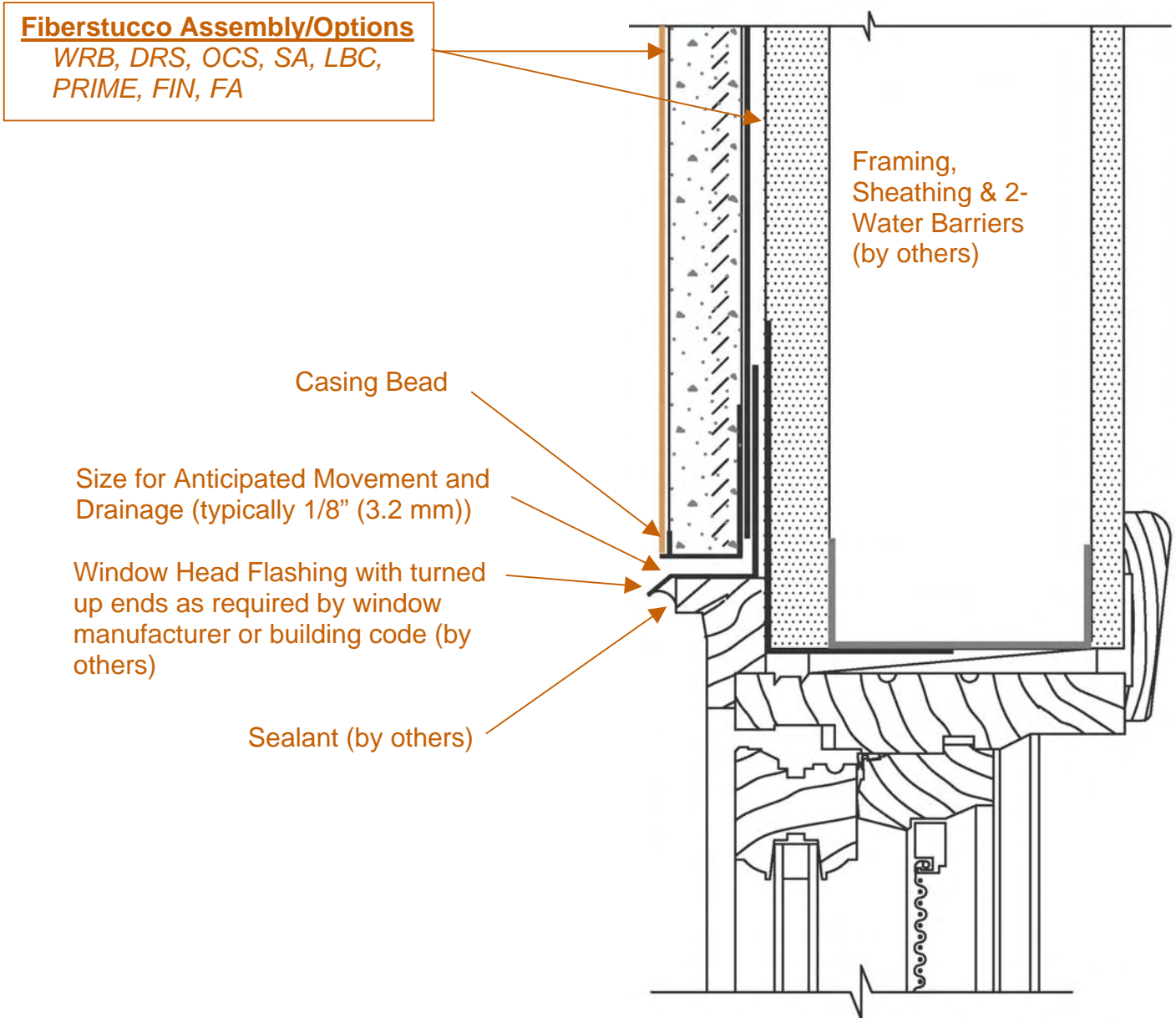

OCSFS-04 Typical Wood Window Head Detail

These drawings relay the conceptual conditions of Master Wall Systems and are not the construction drawings. Ultimately the design and detailing of an entire wall system is the responsibility of a professional. These details will guide the design professional in the use of Master Wall Products. Master Wall disclaims design, warranty or construction intent or responsibility.

Conceptual Details

Corporate • P.O. Box 397 • Fortson • Georgia • 31808 • 800-755-0825 • FAX 706-569-6704

Technical • 800-760-2861 • FAX 734-433-0930

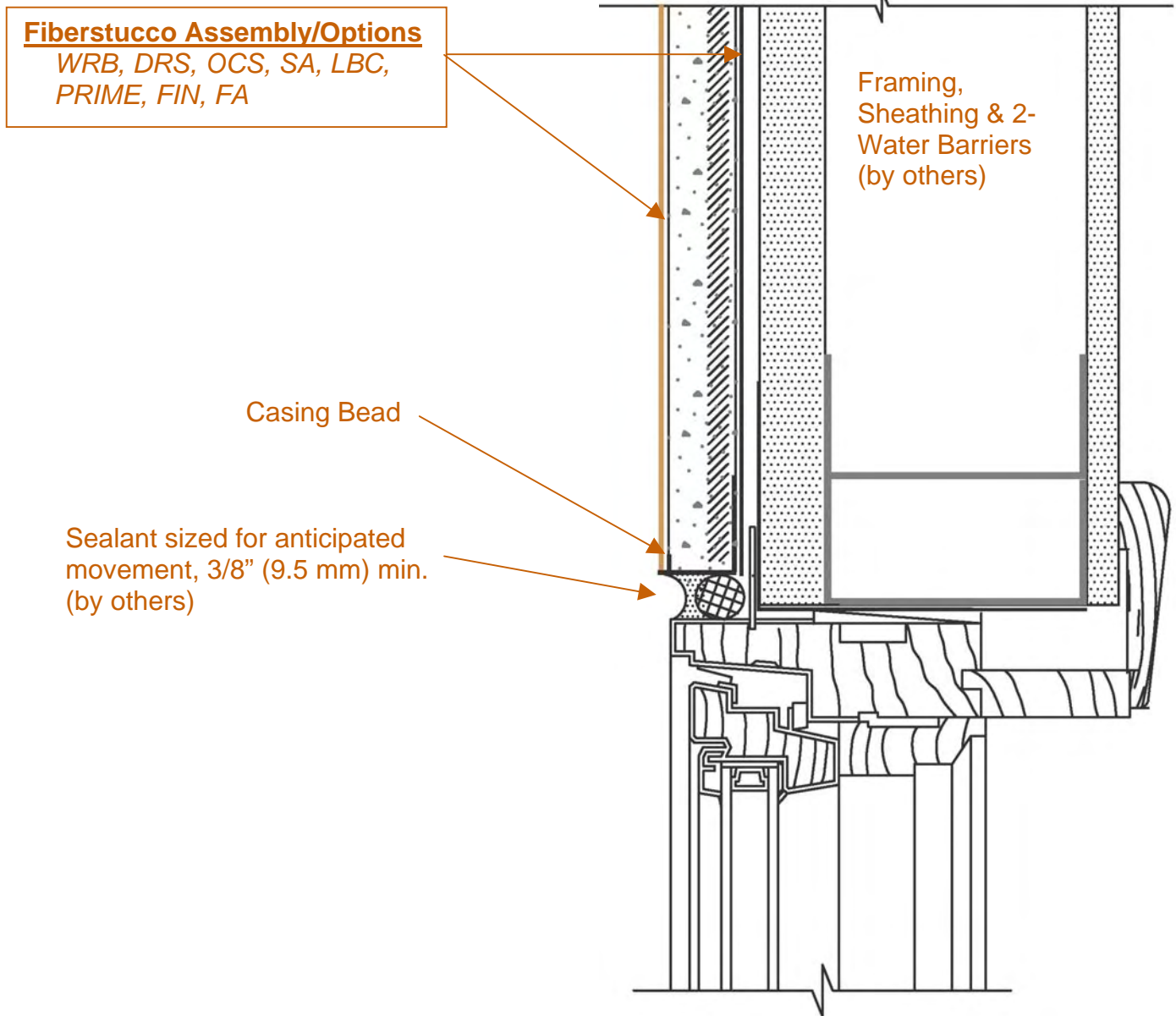

OCSFS-05 Typical Jamb Detail

These drawings relay the conceptual conditions of Master Wall Systems and are not the construction drawings. Ultimately the design and detailing of an entire wall system is the responsibility of a professional. These details will guide the design professional in the use of Master Wall Products. Master Wall disclaims design, warranty or construction intent or responsibility.

Conceptual Details

Corporate • P.O. Box 397 • Fortson • Georgia • 31808 • 800-755-0825 • FAX 706-569-6704

Technical • 800-760-2861 • FAX 734-433-0930

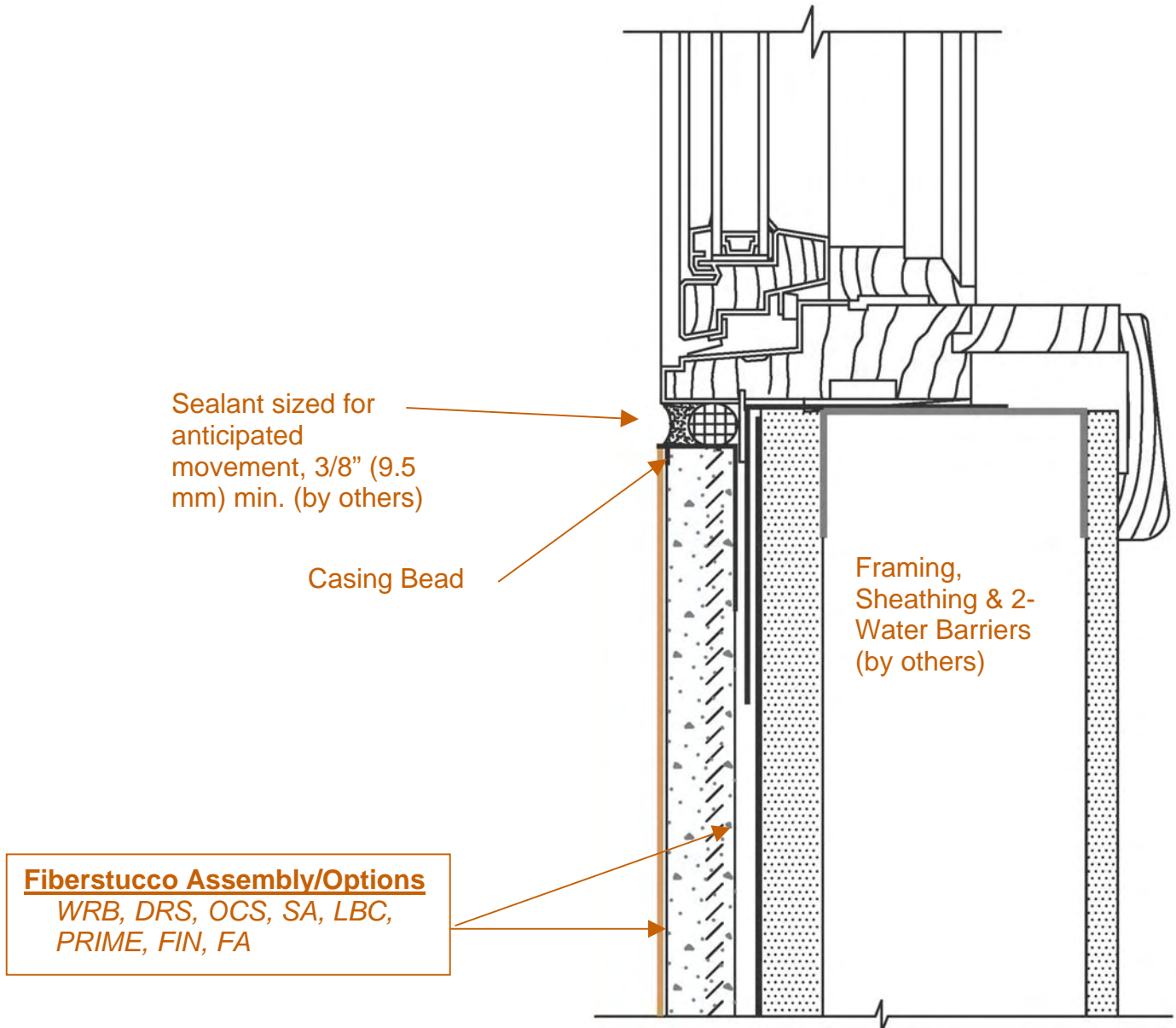

OCSFS-06 Typical Sill Detail

These drawings relay the conceptual conditions of Master Wall Systems and are not the construction drawings. Ultimately the design and detailing of an entire wall system is the responsibility of a professional. These details will guide the design professional in the use of Master Wall Products. Master Wall disclaims design, warranty or construction intent or responsibility.

Conceptual Details

Corporate • P.O. Box 397 • Fortson • Georgia • 31808 • 800-755-0825 • FAX 706-569-6704

Technical • 800-760-2861 • FAX 734-433-0930

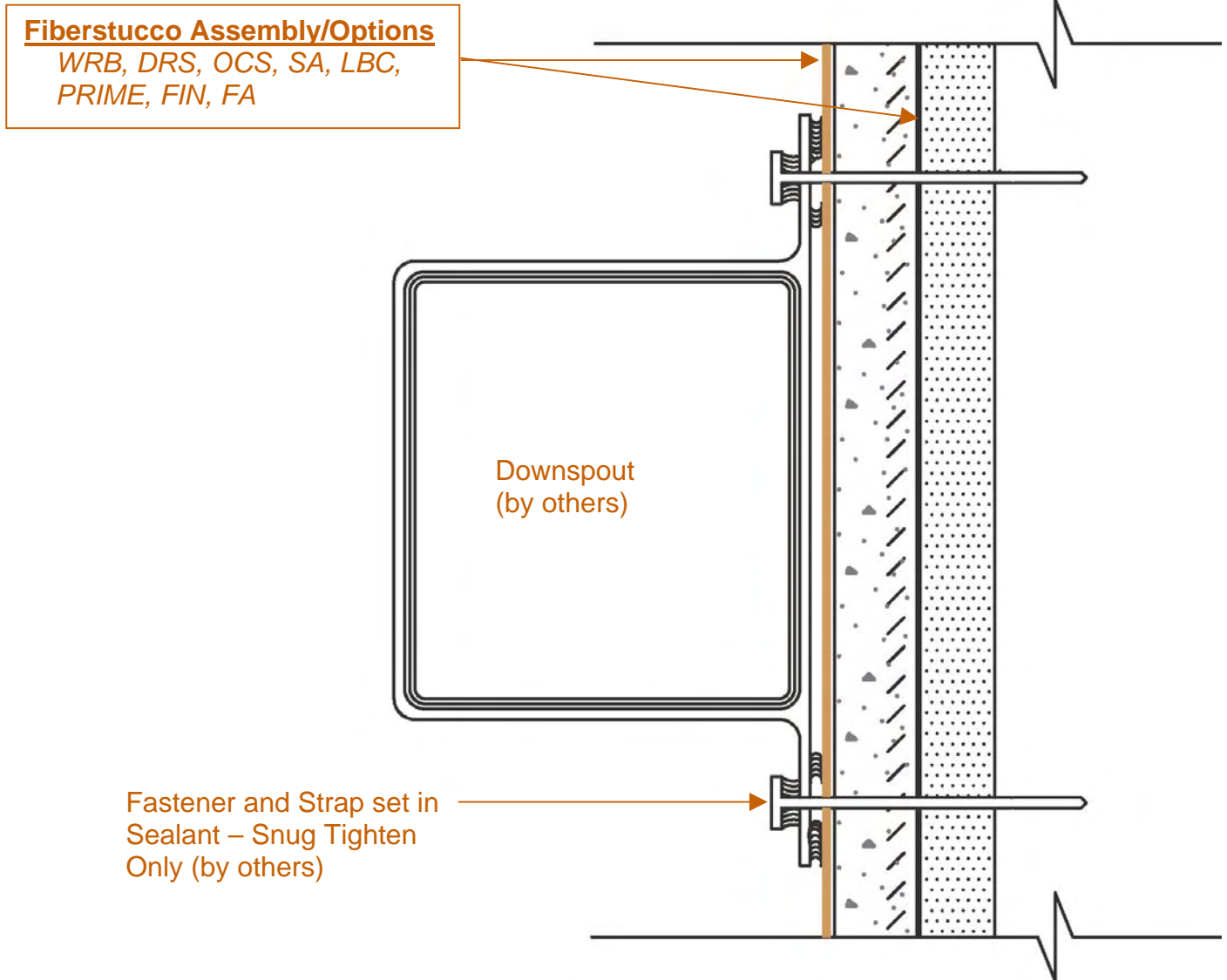

OCSFS-07 Typical Downspout Attachment

These drawings relay the conceptual conditions of Master Wall Systems and are not the construction drawings. Ultimately the design and detailing of an entire wall system is the responsibility of a professional. These details will guide the design professional in the use of Master Wall Products. Master Wall disclaims design, warranty or construction intent or responsibility.

Conceptual Details

Corporate • P.O. Box 397 • Fortson • Georgia • 31808 • 800-755-0825 • FAX 706-569-6704

Technical • 800-760-2861 • FAX 734-433-0930

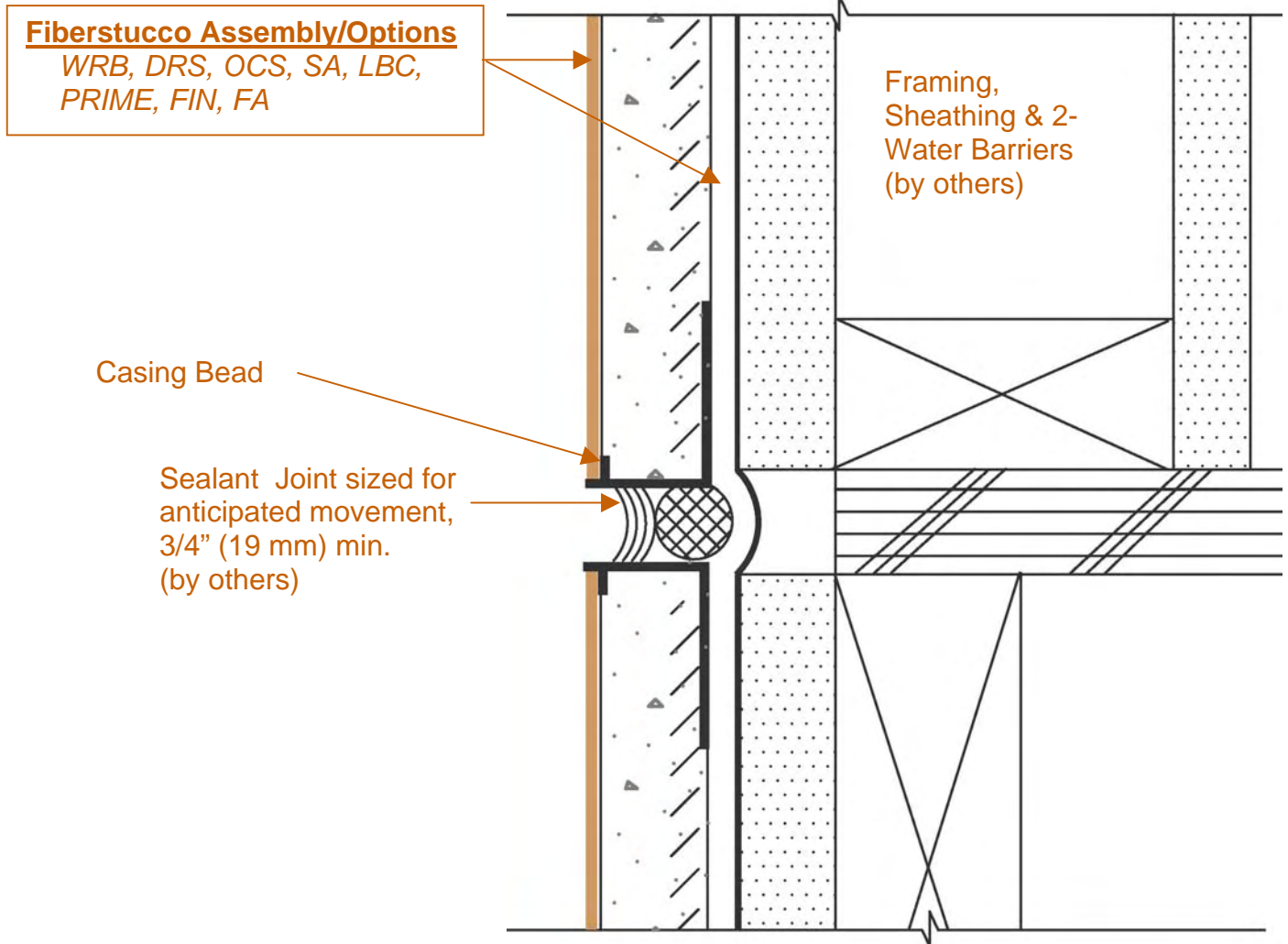

OCSFS-08 Typical Horizontal Expansion Joint at Floor Line – Wood Frame Construction

These drawings relay the conceptual conditions of Master Wall Systems and are not the construction drawings. Ultimately the design and detailing of an entire wall system is the responsibility of a professional. These details will guide the design professional in the use of Master Wall Products. Master Wall disclaims design, warranty or construction intent or responsibility.

Conceptual Details

Corporate • P.O. Box 397 • Fortson • Georgia • 31808 • 800-755-0825 • FAX 706-569-6704

Technical • 800-760-2861 • FAX 734-433-0930

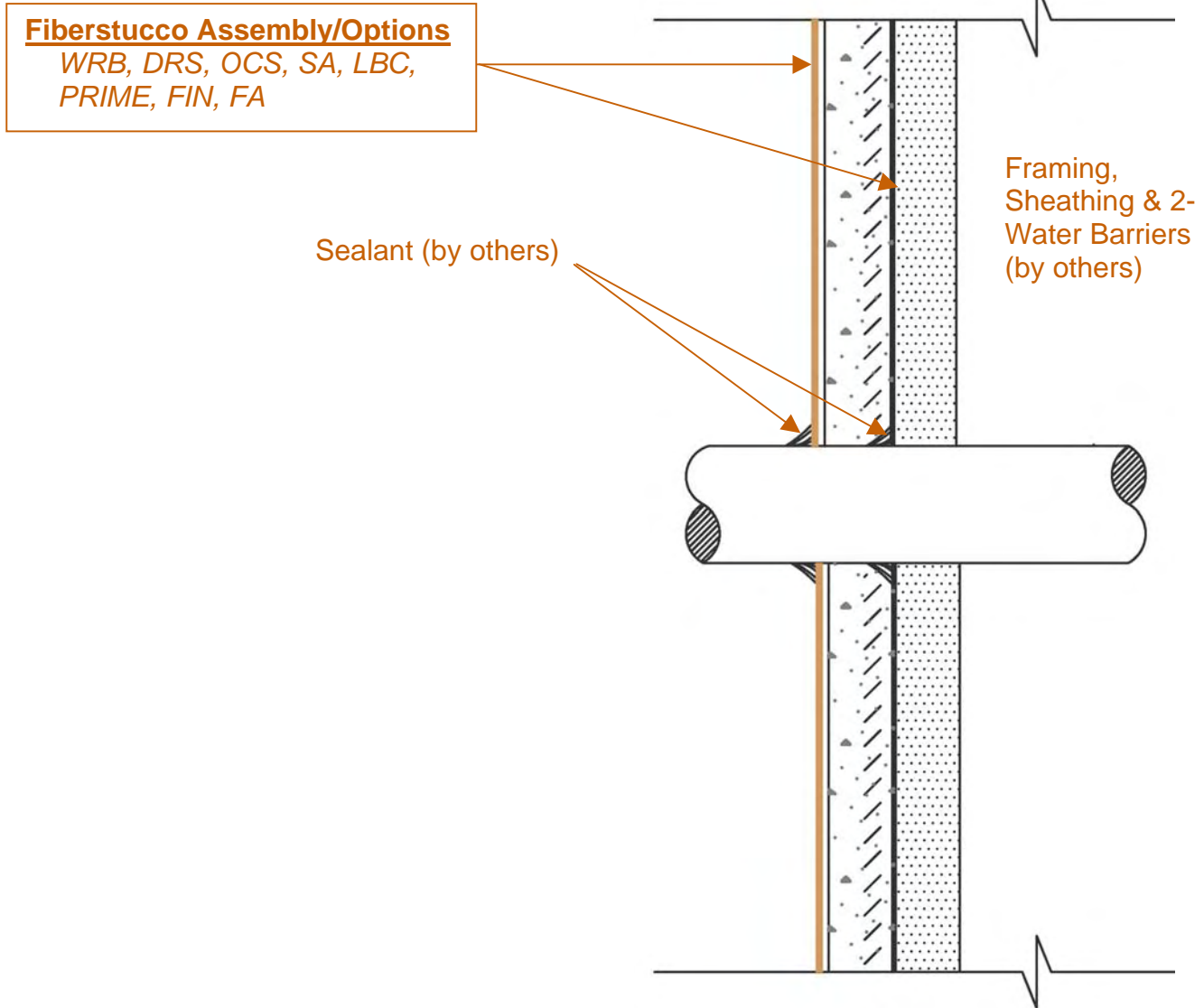

OCSFS-09 Pipe Penetration Detail

These drawings relay the conceptual conditions of Master Wall Systems and are not the construction drawings. Ultimately the design and detailing of an entire wall system is the responsibility of a professional. These details will guide the design professional in the use of Master Wall Products. Master Wall disclaims design, warranty or construction intent or responsibility.

Conceptual Details

Corporate • P.O. Box 397 • Fortson • Georgia • 31808 • 800-755-0825 • FAX 706-569-6704

Technical • 800-760-2861 • FAX 734-433-0930

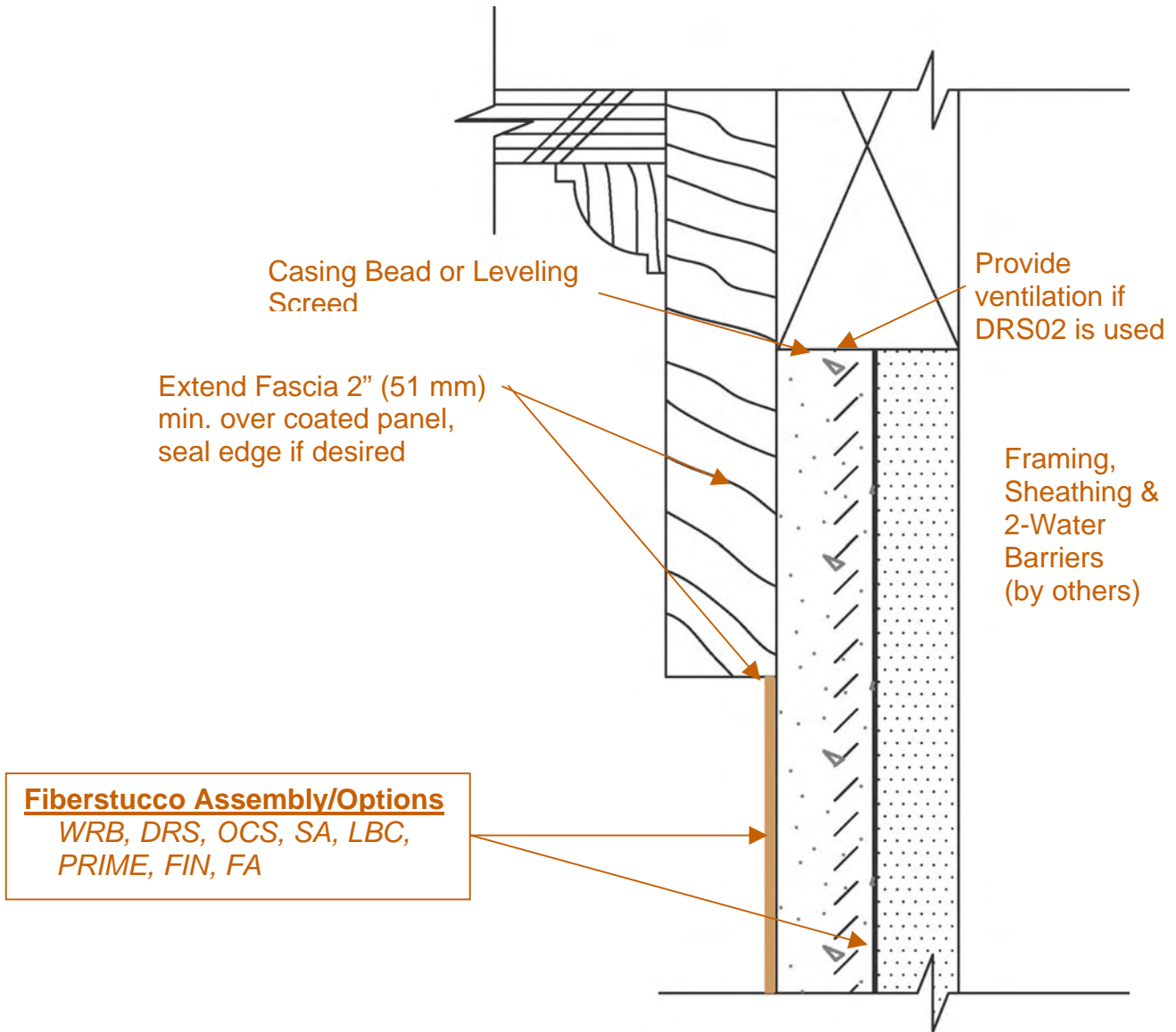

OCSFS-10 Soffit/Gable Termination

These drawings relay the conceptual conditions of Master Wall Systems and are not the construction drawings. Ultimately the design and detailing of an entire wall system is the responsibility of a professional. These details will guide the design professional in the use of Master Wall Products. Master Wall disclaims design, warranty or construction intent or responsibility.

Conceptual Details

Corporate • P.O. Box 397 • Fortson • Georgia • 31808 • 800-755-0825 • FAX 706-569-6704

Technical • 800-760-2861 • FAX 734-433-0930

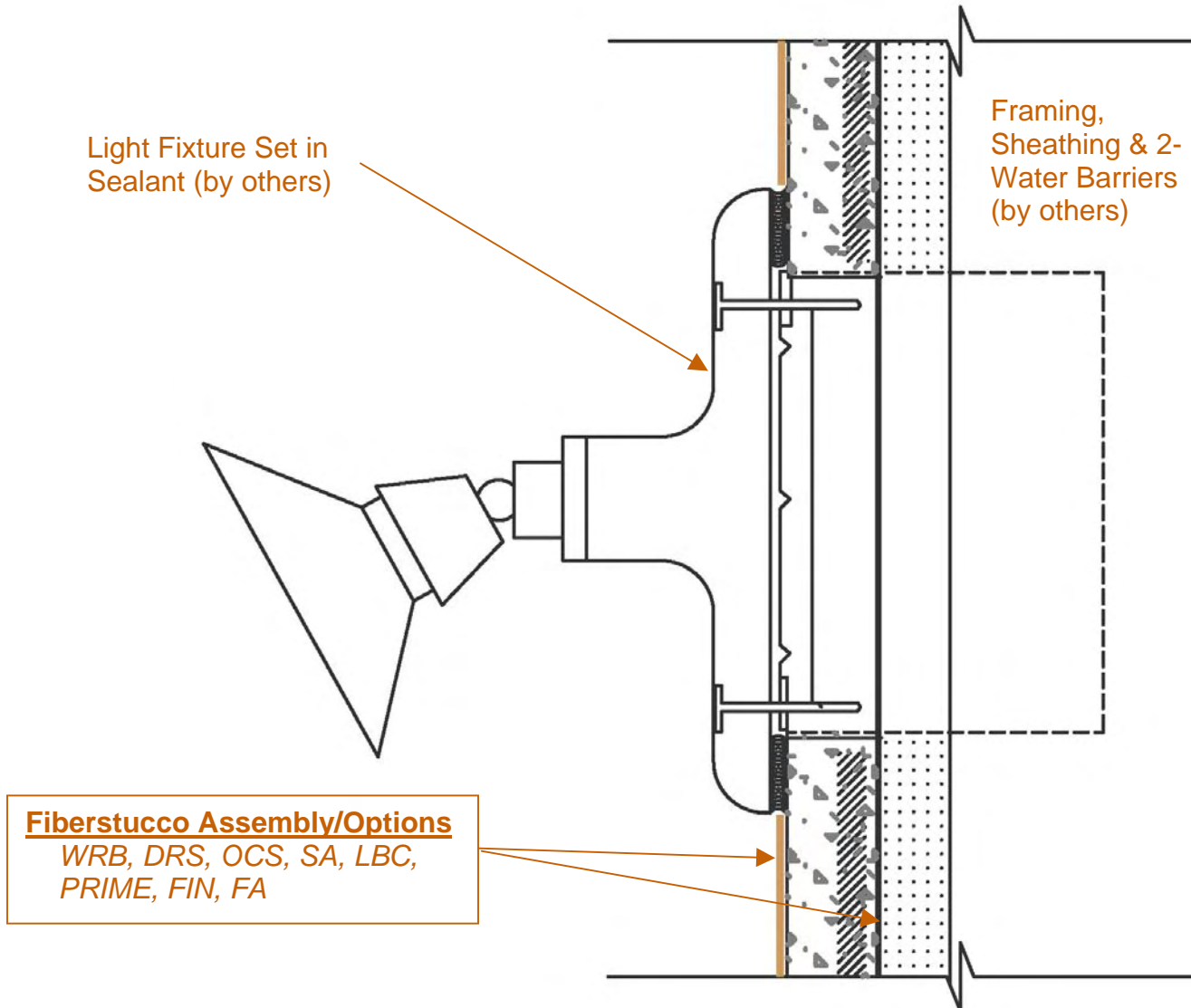

OCSFS-11 Typical Light Fixture

These drawings relay the conceptual conditions of Master Wall Systems and are not the construction drawings. Ultimately the design and detailing of an entire wall system is the responsibility of a professional. These details will guide the design professional in the use of Master Wall Products. Master Wall disclaims design, warranty or construction intent or responsibility.

Conceptual Details

Corporate • P.O. Box 397 • Fortson • Georgia • 31808 • 800-755-0825 • FAX 706-569-6704

Technical • 800-760-2861 • FAX 734-433-0930

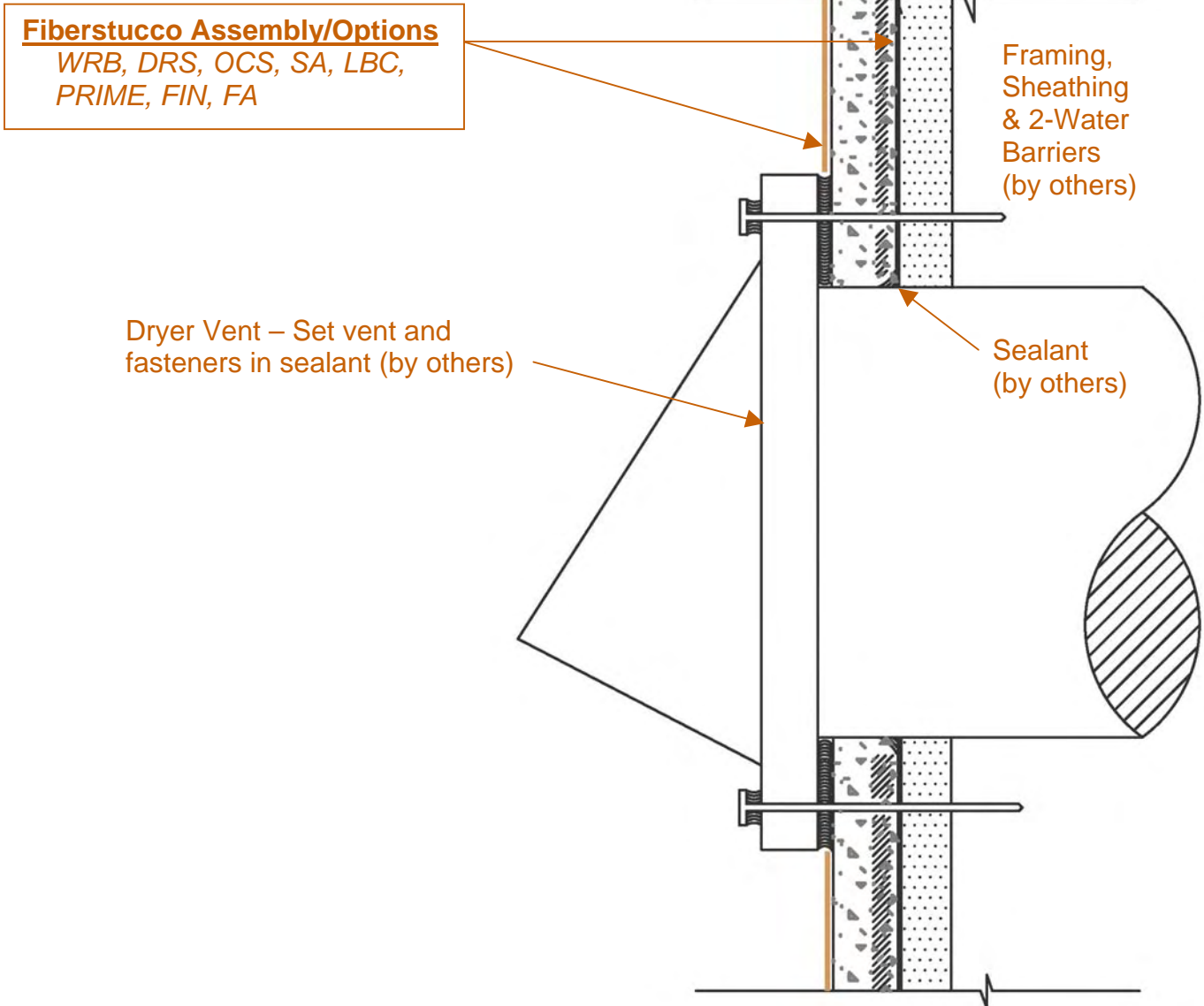

OCSFS-12 Dryer Vent Detail

These drawings relay the conceptual conditions of Master Wall Systems and are not the construction drawings. Ultimately the design and detailing of an entire wall system is the responsibility of a professional. These details will guide the design professional in the use of Master Wall Products. Master Wall disclaims design, warranty or construction intent or responsibility.

Conceptual Details

Corporate • P.O. Box 397 • Fortson • Georgia • 31808 • 800-755-0825 • FAX 706-569-6704

Technical • 800-760-2861 • FAX 734-433-0930

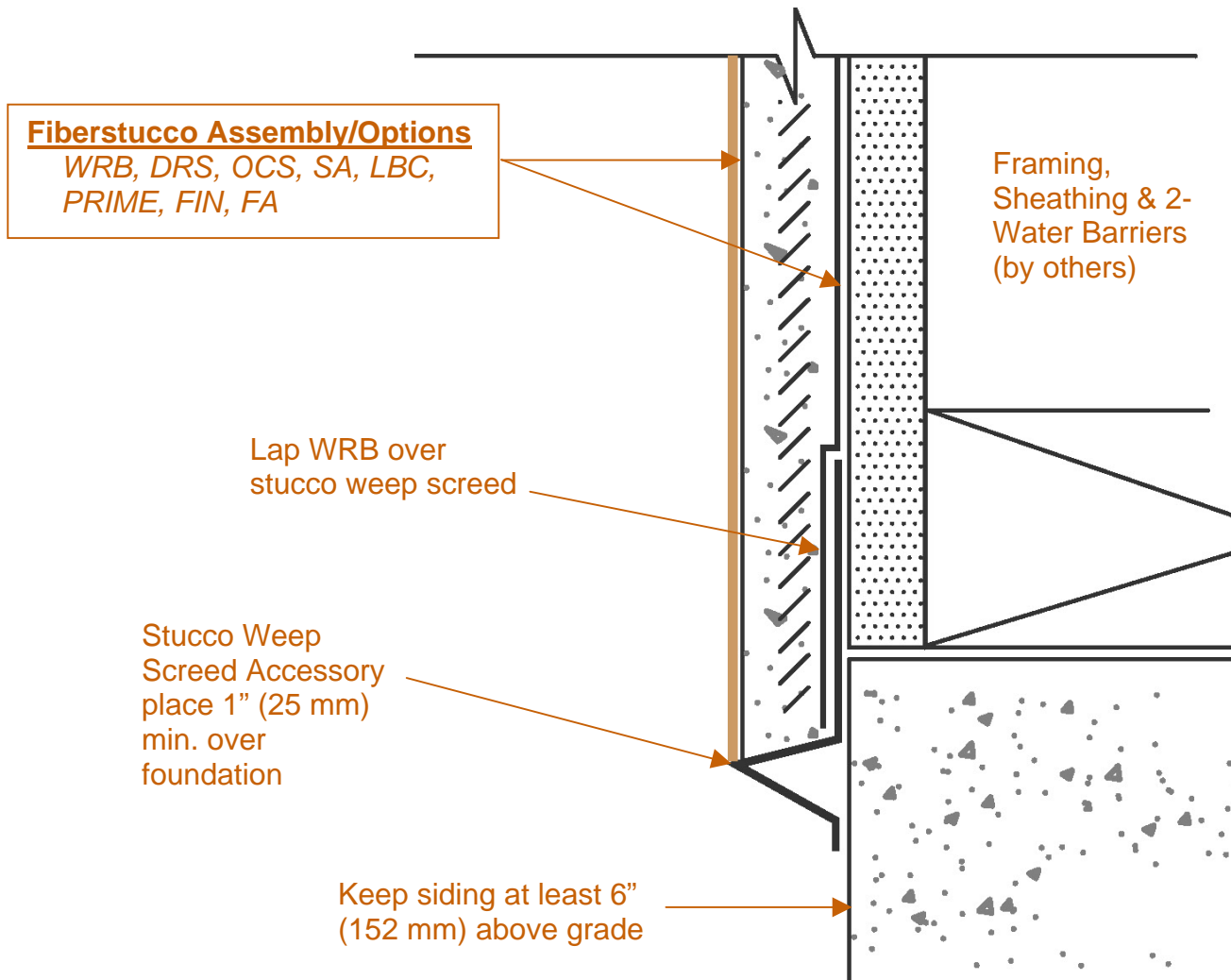

OCSFS-13 Termination at Foundation Detail

These drawings relay the conceptual conditions of Master Wall Systems and are not the construction drawings. Ultimately the design and detailing of an entire wall system is the responsibility of a professional. These details will guide the design professional in the use of Master Wall Products. Master Wall disclaims design, warranty or construction intent or responsibility.

Conceptual Details

Corporate • P.O. Box 397 • Fortson • Georgia • 31808 • 800-755-0825 • FAX 706-569-6704

Technical • 800-760-2861 • FAX 734-433-0930

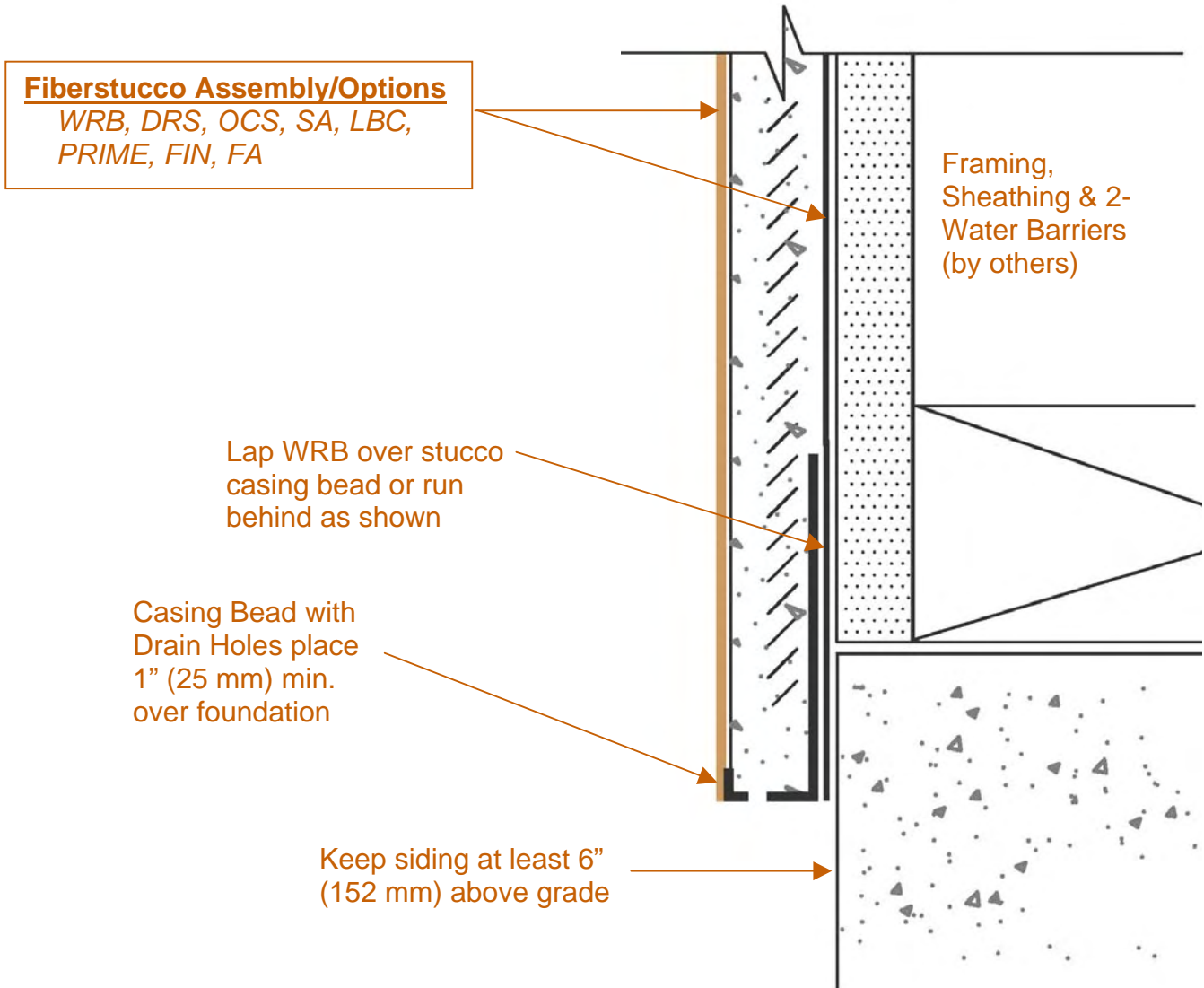

OCSFS-14 Termination at Foundation Detail

These drawings relay the conceptual conditions of Master Wall Systems and are not the construction drawings. Ultimately the design and detailing of an entire wall system is the responsibility of a professional. These details will guide the design professional in the use of Master Wall Products. Master Wall disclaims design, warranty or construction intent or responsibility.

Conceptual Details

Corporate • P.O. Box 397 • Fortson • Georgia • 31808 • 800-755-0825 • FAX 706-569-6704

Technical • 800-760-2861 • FAX 734-433-0930

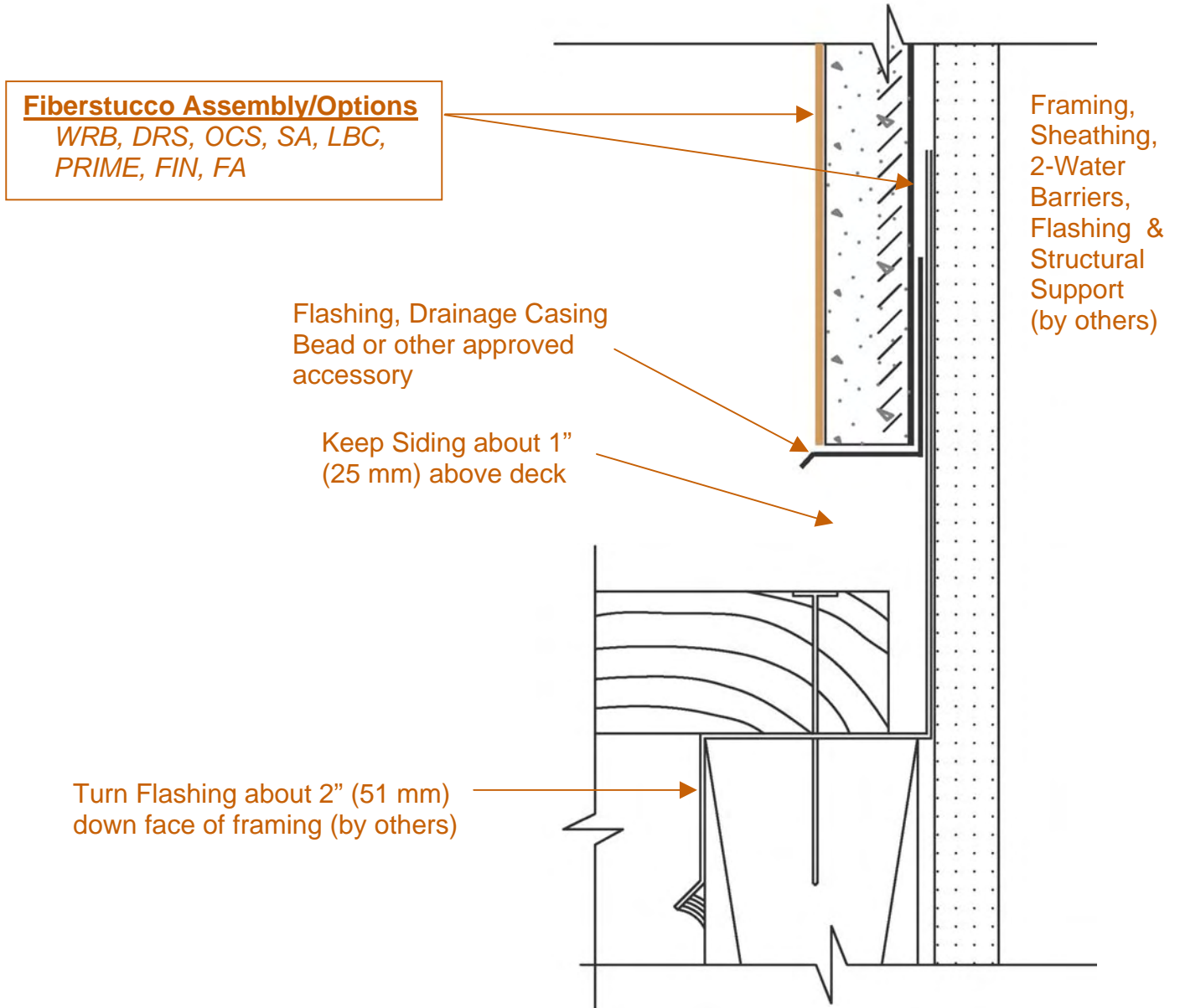

OCSFS-15 Termination at Decking

These drawings relay the conceptual conditions of Master Wall Systems and are not the construction drawings. Ultimately the design and detailing of an entire wall system is the responsibility of a professional. These details will guide the design professional in the use of Master Wall Products. Master Wall disclaims design, warranty or construction intent or responsibility.

Conceptual Details

Corporate • P.O. Box 397 • Fortson • Georgia • 31808 • 800-755-0825 • FAX 706-569-6704

Technical • 800-760-2861 • FAX 734-433-0930

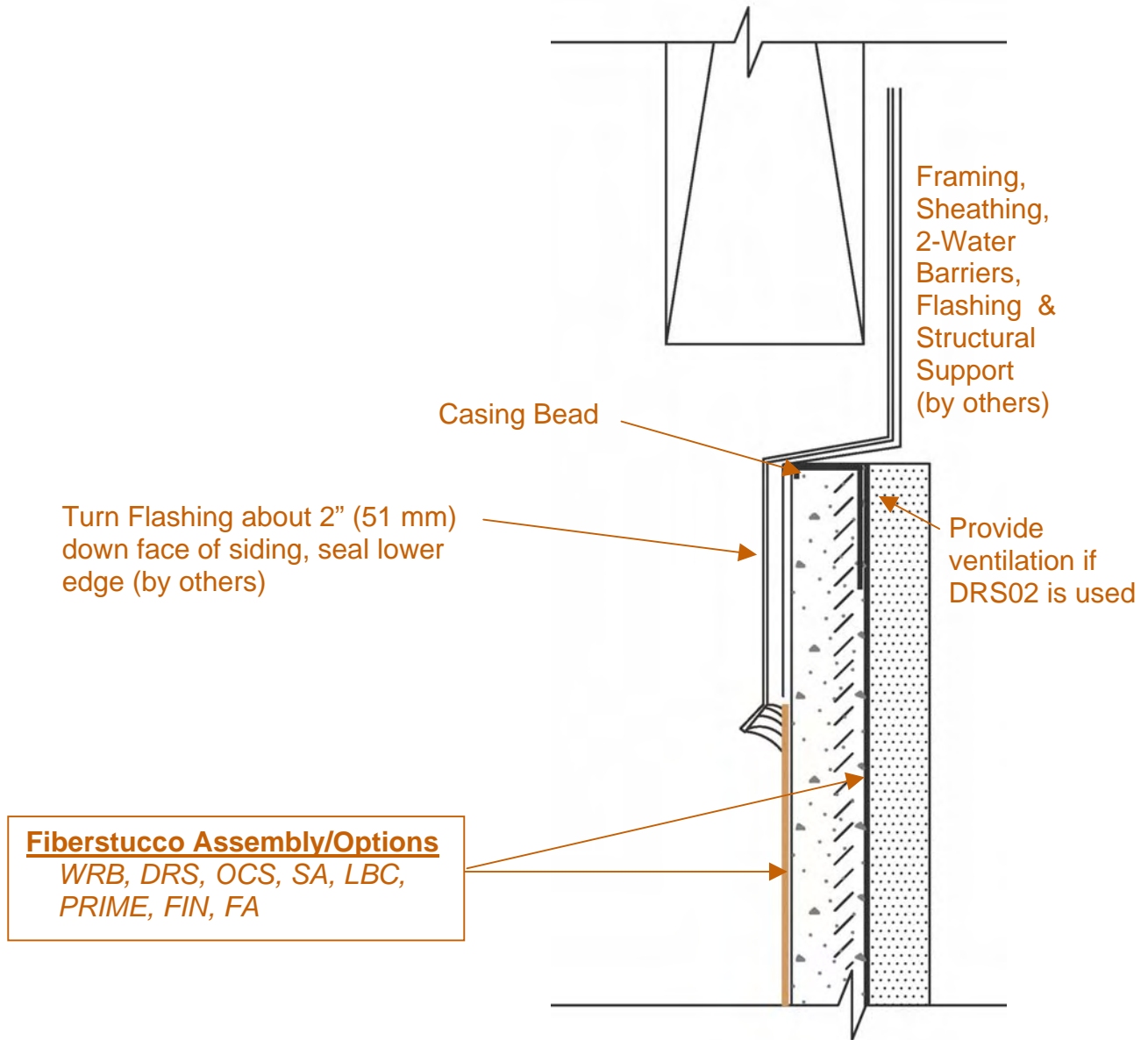

OCSFS-16 Termination Under Deck

These drawings relay the conceptual conditions of Master Wall Systems and are not the construction drawings. Ultimately the design and detailing of an entire wall system is the responsibility of a professional. These details will guide the design professional in the use of Master Wall Products. Master Wall disclaims design, warranty or construction intent or responsibility.

Conceptual Details

Corporate • P.O. Box 397 • Fortson • Georgia • 31808 • 800-755-0825 • FAX 706-569-6704

Technical • 800-760-2861 • FAX 734-433-0930

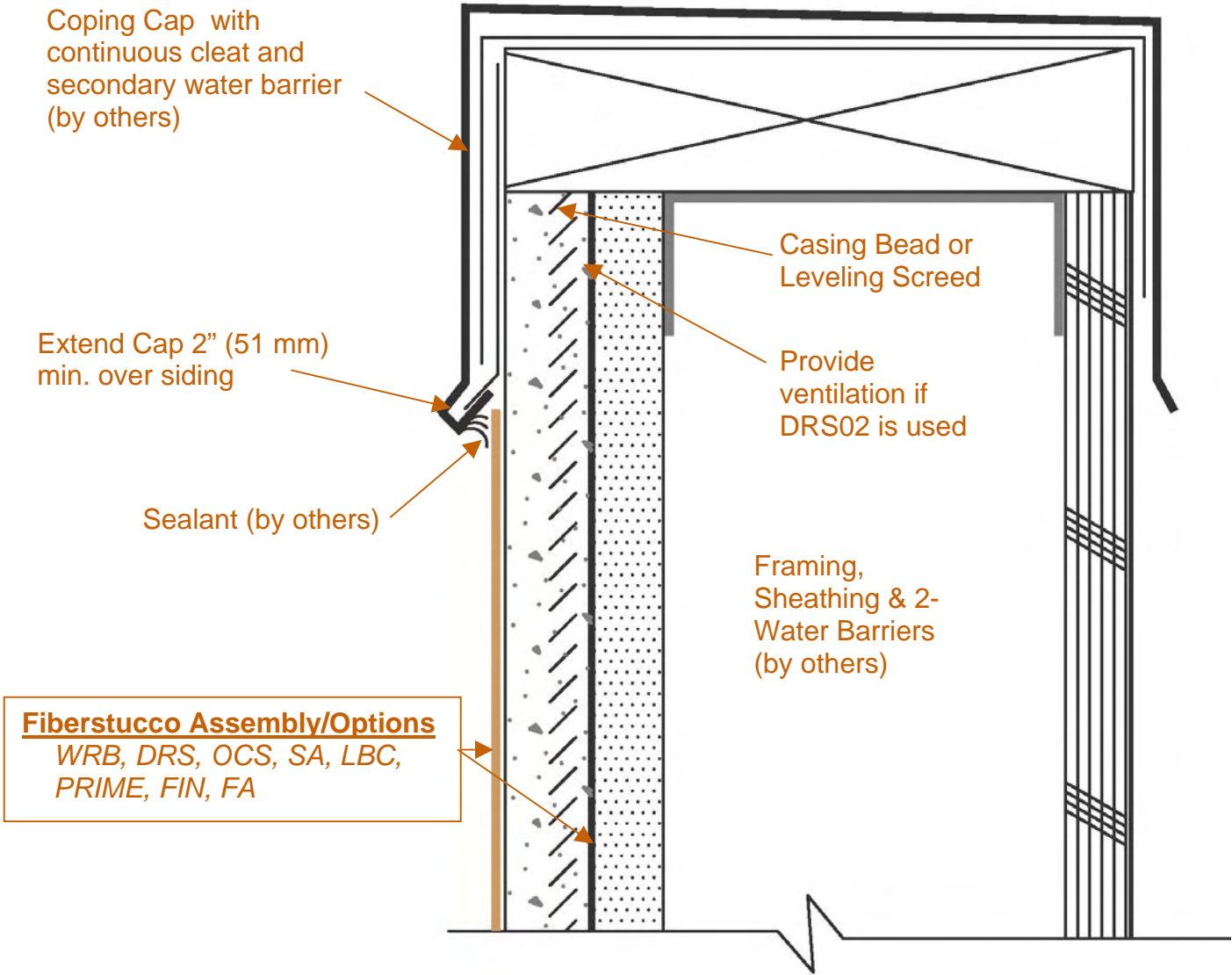

OCSFS-17 Cap Detail

These drawings relay the conceptual conditions of Master Wall Systems and are not the construction drawings. Ultimately the design and detailing of an entire wall system is the responsibility of a professional. These details will guide the design professional in the use of Master Wall Products. Master Wall disclaims design, warranty or construction intent or responsibility.

Conceptual Details

Corporate • P.O. Box 397 • Fortson • Georgia • 31808 • 800-755-0825 • FAX 706-569-6704

Technical • 800-760-2861 • FAX 734-433-0930

Fiberstucco Assembly/Options

WRB, DRS, OCS, SA, LBC,
PRIME, FIN, FA

- Slope 1:2 min. to shed water
- Master Wall Base Coat & Mesh, run at least 2-1/2" (64 mm) onto substrate
- EPS Aesthetic Shape
- Master Wall Adhesive

Notes:

- Use an expansion joint if shape spans control joints
- Primecoat Primer is recommended to minimize any finish color variations due to base coat differences
- Alternatively the shape could be backwrapped and sealed with a sealant (by others)

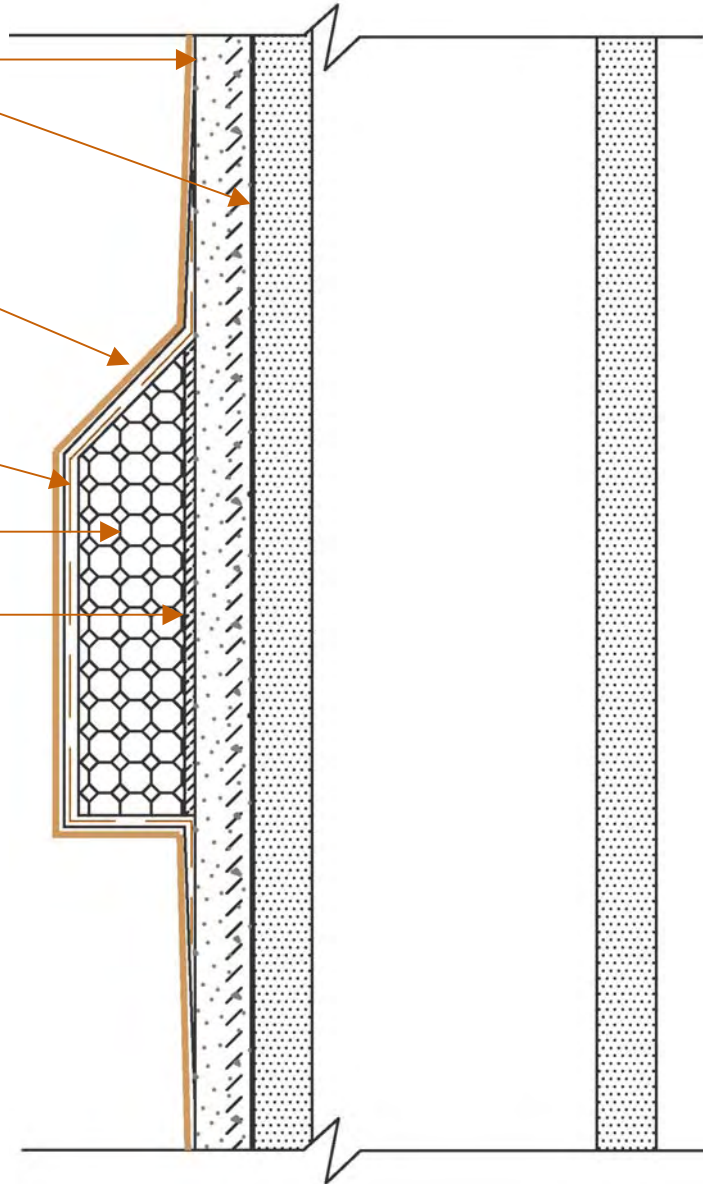

OCSFS-18 EPS Shape Detail

These drawings relay the conceptual conditions of Master Wall Systems and are not the construction drawings. Ultimately the design and detailing of an entire wall system is the responsibility of a professional. These details will guide the design professional in the use of Master Wall Products. Master Wall disclaims design, warranty or construction intent or responsibility.

Conceptual Details

Corporate • P.O. Box 397 • Fortson • Georgia • 31808 • 800-755-0825 • FAX 706-569-6704

Technical • 800-760-2861 • FAX 734-433-0930

Corner Bead or
Cornerite

Fiberstucco Assembly/Options

WRB, DRS, OCS, SA, LBC,
PRIME, FIN, FA

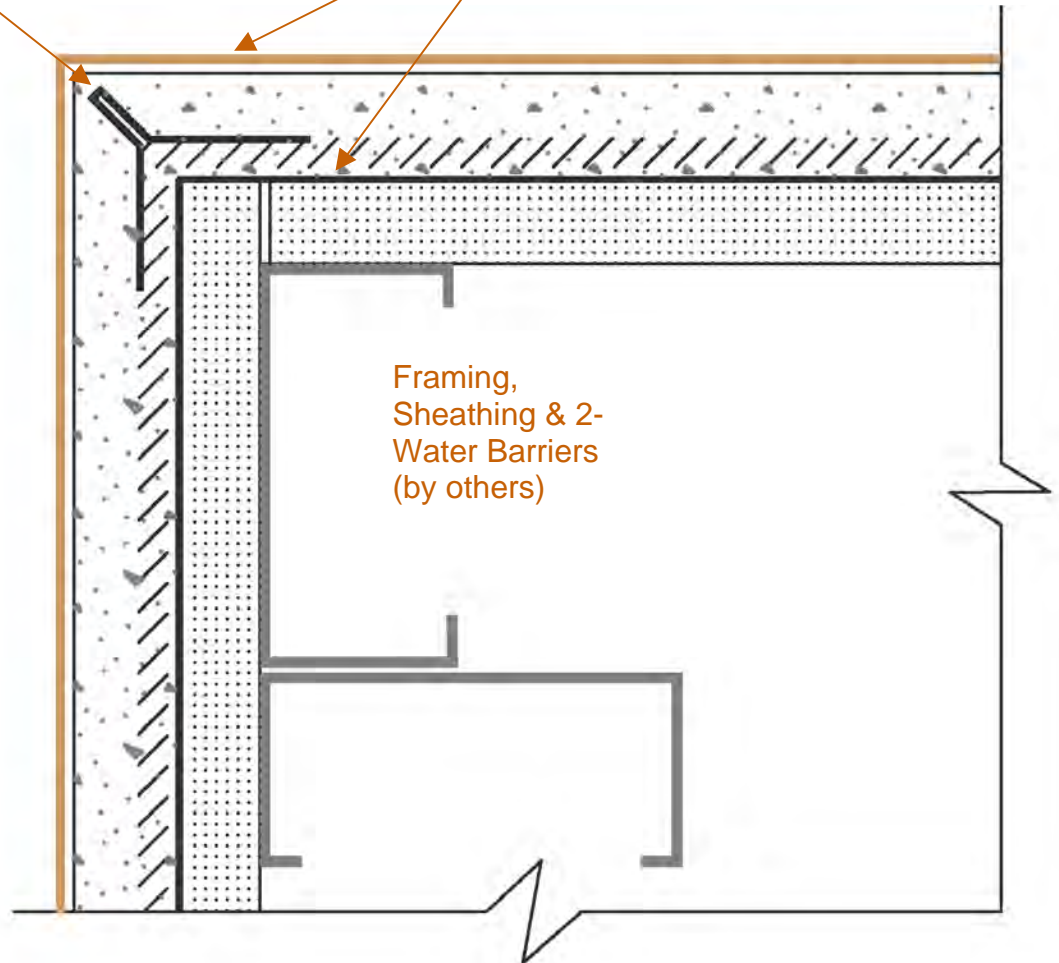

OCSFS-19 Corner Detail

These drawings relay the conceptual conditions of Master Wall Systems and are not the construction drawings. Ultimately the design and detailing of an entire wall system is the responsibility of a professional. These details will guide the design professional in the use of Master Wall Products. Master Wall disclaims design, warranty or construction intent or responsibility.

Conceptual Details

Corporate • P.O. Box 397 • Fortson • Georgia • 31808 • 800-755-0825 • FAX 706-569-6704

Technical • 800-760-2861 • FAX 734-433-0930

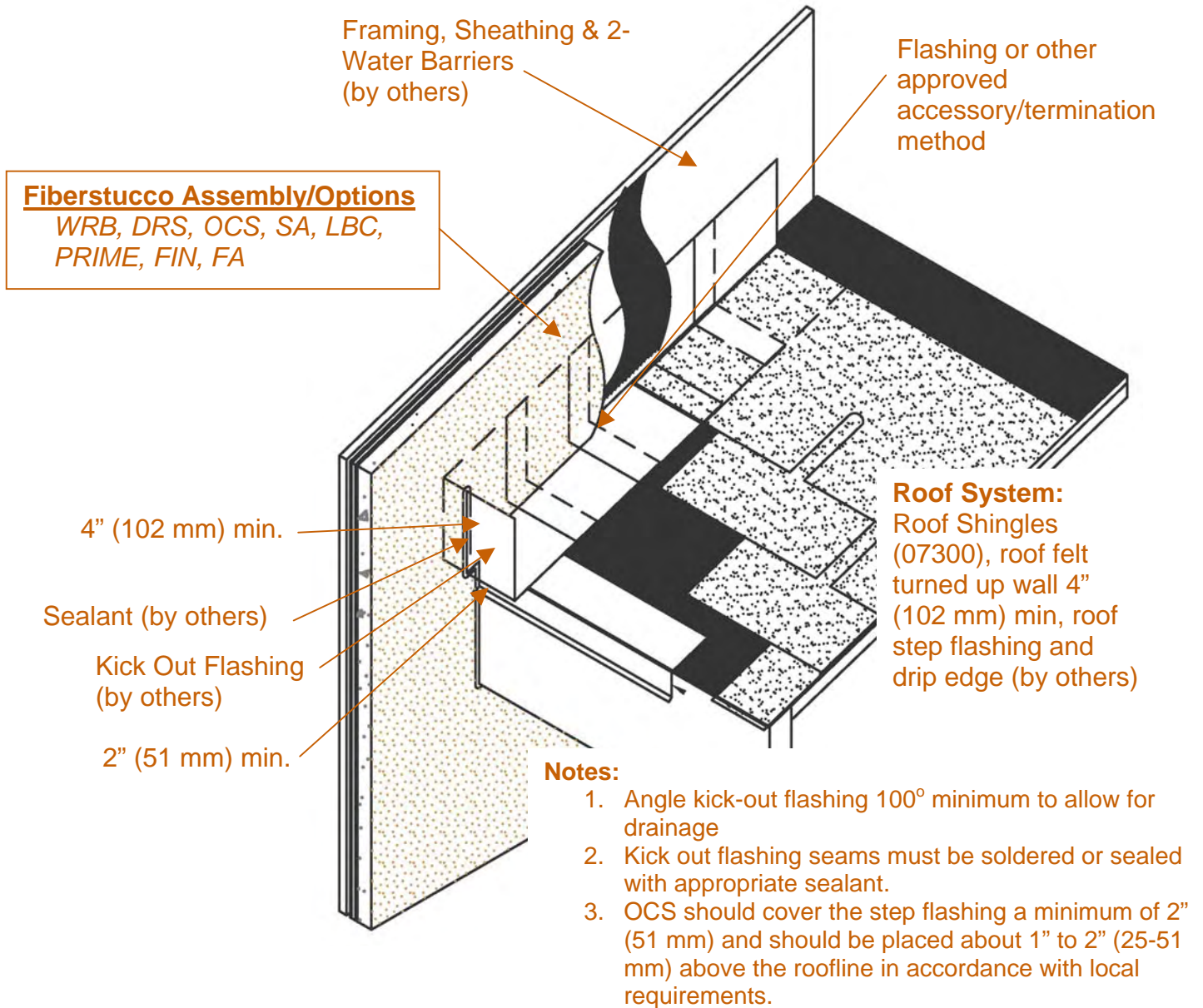

OCSFS-20 Typical Roof/Wall Intersection

These drawings relay the conceptual conditions of Master Wall Systems and are not the construction drawings. Ultimately the design and detailing of an entire wall system is the responsibility of a professional. These details will guide the design professional in the use of Master Wall Products. Master Wall disclaims design, warranty or construction intent or responsibility.



Master Wall One Coat Stucco (OCS) System

7 Year Labor & Material Limited Warranty

Master Wall Inc. warrants the properly designed and installed One Coat Stucco (OCS) system and materials for 7 years from the date of installation. Master Wall Inc.'s exclusive liability under this warranty is to supply replacement materials and labor or corrective procedures, if it is shown that the materials supplied by Master Wall Inc., were defective when installed by the Master Wall Inc. certified applicator. Remedies shall be solely determined by Master Wall Inc. and no other warranties are expressed or implied. For a valid warranty, the system and products must be installed in accordance with Master Wall Inc.'s written recommendations, specifications, details, bulletins and other project-specific written recommendations. Master Wall Inc. must be notified in writing within 10 business days of the original discovery of the defect.

Master Wall Inc., is not responsible for structural conditions, design conditions beyond those noted in our literature, architecture, engineering or workmanship of any project. The OCS system may have hairline cracks, spalling, fastener popping or efflorescence, which are not considered product defects. Materials must be properly stored and applied in a timely manner. Workmanship, aesthetics and installation are beyond the scope of this warranty as are any deviations from Master Wall Inc. Documents not specifically approved in writing.

Abuse, misuse, excessive weather or environmental conditions beyond what the products or systems have been tested, designed or approved for is expressly limited. Certain colors with organic pigments are less fade-resistant than others. The building, system and products must be properly maintained in accordance with Master Wall Inc., documents, local environmental conditions and good building practices. In no case is Master Wall Inc. responsible for incidental and consequential damages.

This warranty becomes effective only when all bills for the components of the system have been paid.

Except as stated, Master Wall, Inc., expressly disclaims any warranty of merchantability or fitness for a particular purpose. The above remedies are to be deemed exclusive.

Project:

Applicator:

Warranty Date: