



Submittal Package

Commercial Drainage EIFS

Project:

Location:

Architect:

General Contractor:

Applicator:

Benefits of Master Wall

- American owned and privately managed, our focus is the customer
- 20+ year track record, projects from coast to coast
- Quality products featuring 100% pure acrylic polymers
- Dedicated to the EIFS & Stucco Markets, it's **what** we do, not part of what our company does
- Experienced Staff—100+ years of experience
- Service—we provide it!
 - Job site visits
 - Color matching
 - Architectural Support
 - Samples
 - Plan, detail and technical reviews
- Dedicated to a culture of excellence

More Information



Commercial Drainage EIFS

Submittal Information:

- *System Data Sheets*
- *Product Data Sheets*
- *Specifications*
- *Details*
- *Sample Labor/Material Limited Warranty*

Manufactured by



P. O. Box 397
Fortson, GA 31808
800-755-0825
Technical 800-760-2861
www.masterwall.com



07 24 13/07 24 19

Commercial Drainage EIFS

Drainage Type Exterior Insulation and Finish System

Master Wall's Aggre-flex Commercial Drainage EIFS is a polymer-based (Class PB) Exterior Insulation and Finish System (EIFS) with a trowel-applied water barrier. The system is applied with vertical drainage channels that help drain any incidental water entering the system and uses WeatherStop Flashing Tape at openings and penetrations.

Features &

Benefits

- 97% Drainage Efficiency
- Heavy, trowel-applied water barrier
- High Insulating Value (R-4 per inch)
- Design Flexibility
- Medium Impact Resistance is standard

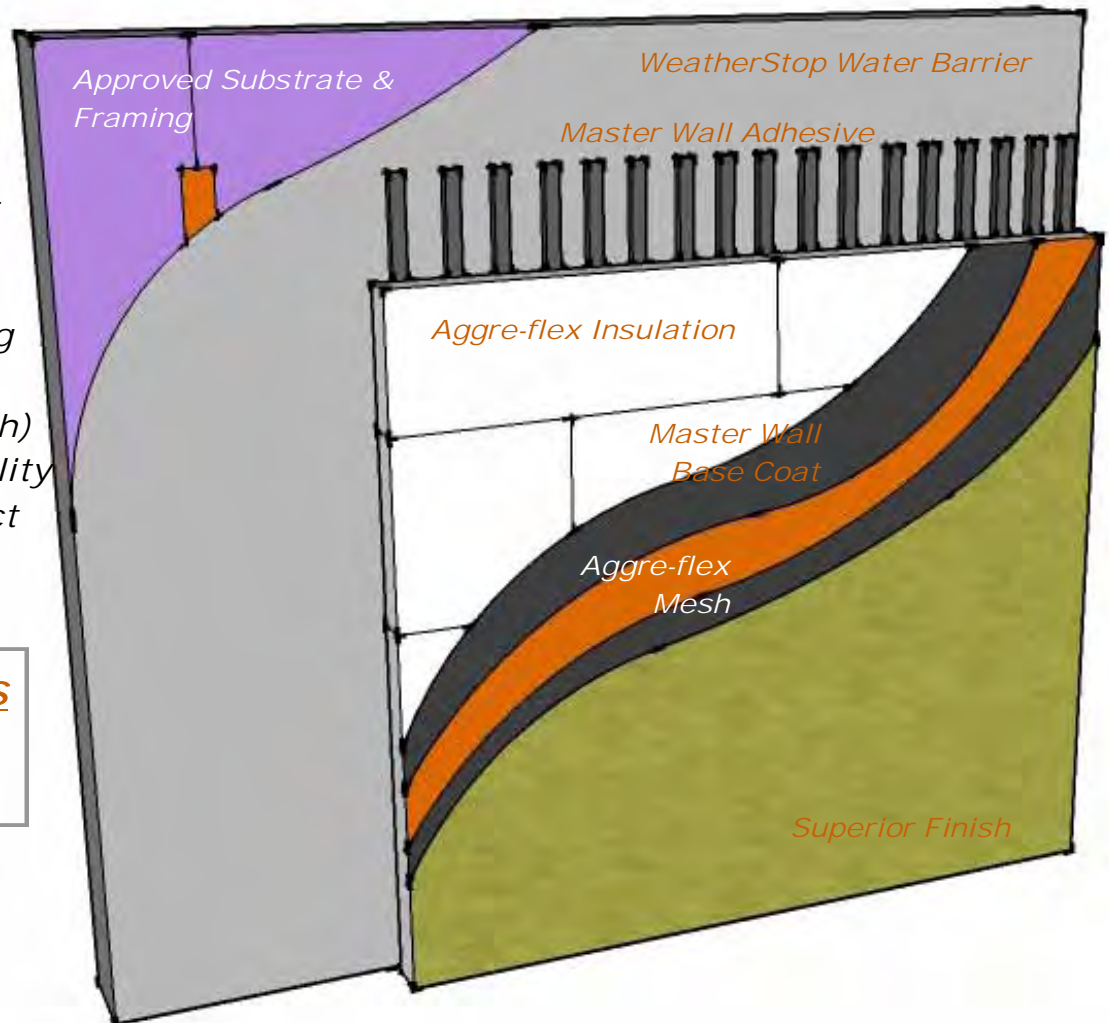

System Uses



©2011 Master Wall Inc.

P. O. Box 397
Fortson, GA 31808
800-755-0825
Technical 800-760-2861
masterwall.com

050111

Aggre-flex Commercial Drainage Short Form Specification

07 24 13 / 07 24 19



1.0 General

This is a short form specification. Refer to *Aggre-flex Commercial Drainage* specifications and details for additional information.

1.1 System Description

The Master Wall *Aggre-flex Commercial Drainage* Exterior Insulation and Finish System (EIFS) is a Class PB (Polymer Based) EIF System consisting of a trowel-applied water barrier, adhesive attachment, insulation board, reinforcing mesh and a textured finish.

1.2 Design Requirements:

- A. Reference Master Wall suggested details and architectural drawings for specific detail requirements.
- B. Slope all surfaces a minimum of 1:2 (6" in 12") to shed water, maximum 12" (305mm) wide.
- C. Maximum deflection of substrates shall not exceed L/240.
- D. Typical acceptable substrates include unpainted brick, masonry, concrete, Dens Glass Gold® (ASTM C-1177). Contact Master Wall for other approved substrates.
- E. Expansion joints are required at building expansion joints, panel joints, floor lines in wood framed construction, and other areas where significant movement occurs.

1.3 Quality Assurance

- A. The system shall be tested for: Accelerated weathering, mildew resistance, salt spray resistance and structural performance.
- B. The system shall have been tested for fire performance in accordance with ASTM E-108, ASTM E-84, UBC 26-9, and Radiant Heat.
- C. The system shall have been tested for water resistance in accordance with ASTM E-331.

1.4 Job Conditions

- A. Store all materials protected from weather and direct sunlight at temperatures above 40°F (5°C).
- B. The ambient and wall temperature shall be a minimum of 40°F (5°C) and shall remain so for at least 24 hours after installation.

See full specifications and
details at masterwall.com

2.0 Products

All components of the Aggre-flex System shall be manufactured by Master Wall and supplied by an authorized distributor.

A. Water Barrier & Flashing Tapes:

1. WeatherStop: A 100% pure acrylic-based adhesive that is field mixed with Type I Portland cement.
2. WeatherStop Tape: A self-adhesive flashing tape.

B. Master Wall Adhesives:

1. Foam & Mesh Adhesive (F&M): A 100% pure acrylic-based adhesive that is field mixed with Portland cement.
2. F&M Plus: A high-build 100% pure acrylic-based fiber reinforced adhesive that is field mixed with Portland cement.
3. Master Wall Bagged Base (MBB): A ready to use dry base that is field mixed with water.

C. Master Wall Insulation Board: Molded Expanded Polystyrene insulation board manufactured to Master Wall specifications.

D. Aggre-flex Mesh: Available in Standard, Detail, Hi-Tech, Medium, Strong and Ultra.

E. Master Wall Base Coats:

1. Foam & Mesh Adhesive (F&M).
2. F&M Plus.
3. Master Wall Bagged Base (MBB).
4. Guardian: A waterproof 100% pure acrylic-based fiber reinforced adhesive that is field mixed with Portland cement.

E. Superior Finish: 100% pure acrylic formulation with integral color and texture. Perfect, Spray, Desert Sand, R-Coarse and Refinish textures.

F. Master Wall Coatings:

1. Primecoat: A water-based primer.
2. Sanded Primecoat: Sanded water-based primer.
3. Roller-flex: A water-based architectural finish coating.

3.0 Installation

A. Inspect the substrate to ensure that it is free of all foreign materials that would affect the adhesion of the *Aggre-flex Commercial Drainage* System.

B. Apply the system in strict accordance with Master Wall specifications, product data sheets, architectural drawings and architectural specifications.

SUPERIOR *finishes*

Integrally Colored Textured Acrylic Finishes



Perfect Texture



Spray Texture



Desert Sand Texture



R-Coarse Texture



Refinish Texture

M Master Wall Inc.
Building a Culture of Excellence



Superior Finish is Master Wall's textured finish line. Available in standard or custom colors, Superior Finishes may be applied over Master Wall Base Coats or prepared substrates including brick, masonry, concrete and stucco. Superior Finishes work great for interior applications as well. Superior Finish is available in five-gallon (19L) pails and is typically troweled onto the wall surface with a stainless steel trowel.

Estimated Coverage

Perfect: 120-150 sf/pail (11-14 sm)
 Spray SS: 215-225 sf/pail (20-21 sm)
 Desert Sand SS: 130-150 sf/pail (12-14 sm)
 R-Coarse: 90-120 sf/pail (8.4-11 sm)
 Perfect West: 140-160 sf/pail (13-15 sm)
 Refinish: Varies with Texture

Coverage will vary by application, applicator skill and substrate conditions. Master Wall assumes no responsibility nor liability for coverage.

Finish Properties

Meets or Exceeds:
 ASTM E84 Surface Burning
 ASTM E108 Flame Spread
 ASTM C67 Freeze/Thaw
 ASTM E2485/2570 Freeze/Thaw
 ASTM D2247/E2570 Humidity
 ASTM D3273 Mold/Mildew
 ASTM D968 Abrasion
 ASTM B117 Salt Spray
 ASTM G53 Weathering
 ASTM G23/G154/G155 Weathering

Approved Substrates

Master Wall Base Coats
 Stucco
 Prepared & Base Coated Surfaces of:
 Brick
 Concrete
 Masonry
 Others approved in writing

Statistics

Pail Weight: 70 lbs (32 kg), Refinish 65 lbs (29.5 kg)

Working Time: 1/4 hour @ room temperature

Drying Time: 8-12 hours to set, 48-72 hours to dry @ room temperature. High pigment levels, low temperatures, high humidity extend dry times.

Application Range: 40°-110°F (5°-43°C)

Shelf Life: 2 years

Application Procedure

Job Conditions - Air and substrate temperature for application of *Superior Finishes* must be 40°F (5°C) or higher and must remain 40°F (5°C) or higher for a minimum of 24 hours. Provide temporary protection to protect the wall system from damage until permanent flashings, caps and sealants are installed. Store materials within prescribed temperature limits and out of direct sunlight. High temperatures will reduce working times, Low temperatures and/or high humidity will extend working, set and dry times.

Preparation - The substrate must be approved by Master Wall Inc., clean, dry, structurally sound and free of efflorescence, oil, grease, form release agents and curing compounds or anything that would affect bond. Painted surfaces are not acceptable and must be removed. Concrete and surfaces should cure for a minimum of 28 days. Stucco should be cured until clean, dry and hard—typically 14 days.

Interior drywall should be finished and made ready for paint. Prime surfaces with *Primecoat/Sanded Primecoat* primer prior to finishing.

Base Coats - Must be flat, dry hard, and free of efflorescence. Master Wall base coats must cure a minimum of 12 hours before application of Superior Finish. Substrates of brick, masonry or concrete should be leveled smooth using either Master Wall base coats or stucco.

Mixing - Thoroughly stir *Superior Finish* using a heavy duty 1/2" drill at 400 - 500 rpm and a heavy duty mixing paddle. Small amounts of clean, potable water may be added to obtain a workable consistency. To avoid color variations, add the same amount of water to each pail. Do not exceed 24 ounces (0.7L) of water per pail of finish.

Application — Apply a uniform thickness (about 1/16") of *Superior Finish* to the substrate using a stainless steel trowel. Spread evenly and then scrape the finish coat down to a thickness no greater than the largest aggregate in the material. Immediately float the finish coat using a plastic float to the desired texture. Always maintain a wet edge to achieve uniformity of texture and color.

For Professional Results

- Apply finish coats away from direct sunlight. Cold joints or color variations can occur if the finish dries too quickly.

- Consider priming stucco surfaces with *Primecoat/Sanded Primecoat* to even out finish absorption.
- Surfaces exposed to the weather must be sloped (6:12 minimum).
- Under certain conditions dark colors may show efflorescence on the surface during the cure process.
- Finishes are intended for the approved substrates listed above and should not be applied directly to gypsum board or insulation board products.

Clean Up—Tools and equipment can be cleaned with soapy water while the *Superior Finish* is still wet.

Available Options



Elastomeric Additive



Silicone Additive



Excel Mildew Additive



Master Wall Inc.
Building a Culture of Excellence

P. O. Box 397
 Fortson, GA 31808

800-755-0825

Technical 800-760-2861

masterwall.com

050111

Information contained in this product data sheet conforms to the standard detail recommendations and specifications for the installation of Master Wall Inc. products and is presented in good faith. Master Wall Inc. assumes no liability, expressed or implied as to the architecture, engineering, or workmanship of any project. This information may be concurrent with, or superseded by other applicable documents, such as specifications and details. Contact Master Wall Inc. for the most current product information.



Foam & Mesh Adhesive (F&M) is a high performance base coat and adhesive used in Master Wall Systems or over prepared substrates including brick, masonry, concrete and stucco. F&M is available in five-gallon (19L) pails and is mixed 1:1 with Portland cement to a creamy consistency. F&M trowels out smoothly with a stainless steel trowel and is the premium choice for embedding mesh or leveling walls.

Foam & Mesh Adhesive & Base Coat

Application Procedure

Job Conditions - Air and substrate temperature for application of F&M must be 40°F (5°C) or higher and must remain 40°F (5°C) or higher for a minimum of 24 hours. Provide temporary protection to protect the wall system from damage until permanent flashings, caps and sealants are installed. Store materials within prescribed temperature limits and out of direct sunlight. Working and drying times are based upon normal room temperature conditions and will vary with temperature and humidity.

Preparation - The substrate must be approved by Master Wall Inc., clean, dry, structurally sound and free of efflorescence, oil, grease, form release agents and curing compounds or anything that would affect bond. Painted surfaces are not acceptable and must be removed.

Mixing - Thoroughly stir F&M using a heavy duty 1/2" (12.7 mm) drill at 400 - 500 rpm and a heavy duty mixing paddle. Pour half of the stirred F&M into a clean plastic pail. Add Type I or I-II Portland cement to the half pail of F&M in a ratio of one-to-one by weight and mix to a homogenous consistency. Let the mixture stand for 3 to 5 minutes and then stir to a creamy consistency. Up to 30 ounces (0.9L) of clean, potable water may be added to a half pail to adjust workability. Do not over mix as faster setting or reduced working time can occur. Do not add accelerators or retarders to the F&M mixture.

Application

Adhesive application – Over gypsum substrates, apply the F&M mixture directly to the back of the insulation board using a 3/8"x3/8"x3/8" (9.5x9.5x9.5 mm) or a 3/8"x1/2"x1-1/2" (9.5x13x38 mm) stainless steel notched trowel. With the trowel at a 45° angle, cover the entire back of the insulation board with full beads of adhesive. Apply the adhesive so the ribbons run vertically when applied to the wall.

Over non-gypsum substrates, you may use the above described notched trowel method or the 'ribbon and dab' method. Using a stainless steel plastering trowel, apply a 2" (50.8 mm) wide by 3/8" (9.5 mm) high ribbon of the F&M mixture around the entire perimeter of the insulation board. Place 8 dabs of the F&M mixture 3/8" (9.5 mm) thick by 4" (102 mm) in diameter approximately 8" (204 mm) on center inside the ribbon.

Immediately place the prepared insulation board on the substrate. Make sure that all edges of the insulation board are abutted tightly and that no F&M mixture gets into the board joints. Do not allow the F&M mixture to form a skin prior to placing the insulation board on the substrate. Do not apply the F&M mixture directly onto the substrate.

For base coat application – All imperfections in the insulation board must be rasped flush and any gaps in the insulation board must be filled with slivers of insulation. Apply the F&M mixture over the entire surface of the insulation board in a thickness greater than that of the reinforcing fabric being used (approximately 1/16" (1.6 mm) for standard mesh and 3/32" (2.4 mm) for Ultra Mesh). Immediately embed the reinforcing fabric into the wet F&M mixture and smooth from the center to the edge to avoid wrinkles. The reinforcing fabric must be continuous at all corners and lapped or abutted in accordance to Master Wall specifications. The color of the mesh shall not be visible but a slight mesh pattern may be visible.

Statistics

Coverage (Estimated/varies)

Adhesive & Standard Base: 120 sf (11 sm)
 Single Layer Mesh Only : 240-280 sf (22-26 sm)
 Double Layer Mesh Only: 80-230 sf (7.5-21 sm)
 Notched Trowel Only: 135 sf (12.5 sm)

Pail Weight: 60 lbs (27kg)

Working Time: 1 hour @ room temperature

Drying Time: 12 hours @ room temperature

Application Range: 40°-110°F (5°-43°C)

Shelf Life: 2 years

Clean Up—Tools and equipment can be cleaned with soapy water while the F&M is still wet.

Approved Substrates

- Exterior gypsum sheathing (ASTM C79, C1177)
- Dens Glass Gold®
- GlasRoc®
- FiberBond®
- Gold Bond e²xp®
- Securock®
- Durock®
- PermaBase®
- Util-A-Crete®, ProTEC®, ProGUARD®
- Concrete
- Brick
- Masonry
- Metal Lath
- Others approved in writing



Information contained in this product data sheet conforms to the standard detail recommendations and specifications for the installation of Master Wall Inc. products and is presented in good faith. Master Wall Inc. assumes no liability, expressed or implied as to the architecture, engineering, or workmanship of any project. This information may be concurrent with, or superseded by other applicable documents, such as specifications and details. Contact Master Wall Inc. for the most current product information.

P. O. Box 397
 Fortson, GA 31808
 800-755-0825
 Technical 800-760-2861
www.masterwall.com



Master Wall Bagged Base (MBB) is a dry version of

Master Wall Bagged Base Adhesive & Base Coat

our Foam & Mesh Adhesive (F&M). Use MBB as an adhesive or base coat in Master Wall Systems or over prepared substrates including brick, masonry, concrete and stucco. MBB is freeze stable in dry form and is easily mixed with clean potable water to a creamy consistency.

Application Procedure

Job Conditions - Air and substrate temperature for application of *MBB* must be 40°F (5°C) or higher and must remain 40°F (5°C) or higher for a minimum of 24 hours. Provide temporary protection to protect the wall system from damage until permanent flashings, caps and sealants are installed. Store materials within prescribed temperature limits and out of direct sunlight. Working and drying times are based upon normal room temperature conditions and will vary with temperature and humidity.

Preparation - The substrate must be approved by Master Wall Inc., clean, dry, structurally sound and free of efflorescence, oil, grease, form release agents and curing compounds or anything that would affect bond. Painted surfaces are not acceptable and must be removed.

Mixing - Add 5 to 6 quarts (4.7-5.7L) of potable water to a clean plastic pail. Add the *MBB* slowly while stirring using a heavy-duty 1/2" (12.7 mm) drill at 400 - 500 rpm and a heavy-duty Mixer. Mix thoroughly to a homogenous consistency. Let the mixture stand for 3 to 5 minutes and then stir to a creamy consistency. Small amounts of clean, potable water may be added to obtain a workable consistency. Do not over mix. Excessive stirring may cause faster setting and reduced working time. Do not add accelerators or retarders to the *MBB* mixture.

Application

Adhesive application – Over gypsum substrates, apply the *F&M* mixture directly to the back of the insulation board using a 3/8"x3/8"x3/8" (9.5x9.5x9.5 mm) or a 3/8"x1/2"x1-1/2" (9.5x13x38 mm) stainless steel notched trowel. With the trowel at a 45° angle, cover the entire back of the insulation board with full beads of adhesive. Apply the adhesive so the ribbons run vertically when applied to the wall.

Over non-gypsum substrates, you may use the above described notched trowel method or the 'ribbon and dab' method. Using a stainless steel plastering trowel, apply a 2" (50.8 mm) wide by 3/8" (9.5 mm) high ribbon of the *MBB* mixture around the entire perimeter of the insulation board. Place 8 dabs of the *MBB* mixture 3/8" (9.5 mm) thick by 4" (102 mm) in diameter approximately 8" (204 mm) on center inside the ribbon.

Immediately place the prepared insulation board on the substrate. Make sure that all edges of the insulation board are abutted tightly and that no *MBB* mixture gets into the board joints. Do not allow the *MBB* mixture to form a skin prior to placing the insulation board on the substrate. Do not apply the *MBB* mixture directly onto the substrate.

For base coat application – All imperfections in the insulation board must be rasped flush and any gaps in the insulation board must be filled with slivers of insulation. Apply the *MBB* mixture over the entire surface of the insulation board in a thickness greater than that of the reinforcing fabric being used (approximately 1/16" (1.6 mm) for standard mesh and 3/32" (2.4 mm) for Ultra Mesh). Immediately embed the reinforcing fabric into the wet *MBB* mixture and smooth from the center to the edge to avoid wrinkles. The reinforcing fabric must be continuous at all corners and lapped or abutted in accordance to Master Wall specifications. The color of the mesh shall not be visible but a slight mesh pattern may be visible.

Statistics

Coverage (Estimated/Varies)

Adhesive & Standard Base: 50-60 sf (4.6-5.6 sm)

Single Layer Mesh Only : 100-125 sf (9-11.5 sm)

Double Layer Mesh Only: 30-110 sf (2.5-10 sm)

Notched Trowel Only: 56 sf (5.2 sm)

Bag Weight: 50 lbs (22.7kg)

Working Time: 1 hour @ room temperature

Drying Time: 12 hours @ room temperature

Application Range: 40°-110°F (5°-43°C)

Shelf Life: 1 year

Clean Up—Tools and equipment can be cleaned with soapy water while the *MBB* is still wet.



Master Wall Inc.

Building a Culture of Excellence

Information contained in this product data sheet conforms to the standard detail recommendations and specifications for the installation of Master Wall Inc. products and is presented in good faith. Master Wall Inc. assumes no liability, expressed or implied as to the architecture, engineering, or workmanship of any project. This information may be concurrent with, or superseded by other applicable documents, such as specifications and details. Contact Master Wall Inc. for the most current product information.

Approved Substrates

- Exterior gypsum sheathing (ASTM C79)
- Dens Glass Gold®
- GlasRoc®
- FiberBond®
- Gold Bond e²xp®
- Durock®
- PermaBase®
- Util-A-Crete®, ProTEC®, ProGUARD®
- Concrete
- Brick
- Masonry
- Metal Lath
- Others approved in writing



Aggre-flex Mesh



Master Wall Aggre-flex Mesh is a specially woven, **AR Glass Fiber** glass fiber mesh with AR Coating (Alkali Resistive). **Master Wall Systems**

Embedded in Master Wall base coats, Aggre-flex Mesh is the key impact and tensile component in Master Wall EIFS and wall systems. It can also improve crack resistance in Master Wall Stucco Systems or traditional stucco.

General

Mesh Properties

ASTM D76, D578, D579, D3659, D4029, D5035, E2098, E2486 MIL-Y-1140

Weave: Leno

Mesh	Weight	Roll Size	Tensile (warp/fill)	Coverage*
Detail	4.5 oz/sy (113 g/sm)	9.5" x 150' (96.5cm x 45.7m)	140/150	119 sf (11 sm)
Standard	4.5 oz/sy (113 g/sm)	38" x 150' (96.5cm x 45.7m)	140/150	475 sf (44.1 sm)
Hi-Tech	6.0 oz/sy (202 g/sm)	38" x 150' (96.5cm x 45.7m)	140/250	475 sf (44.1 sm)
Medium	12.0 oz/sy (313 g/sm)	38" x 75' (96.5cm x 22.8m)	300/500	238 sf (22.1 sm)
Strong	15.4 oz/sy (508 g/sm)	38" x 75' (96.5cm x 22.8m)	350/600	238 sf (22.1 sm)
Ultra	21.0 oz/sy (675 g/sm)	38" x 75' (96.5cm x 22.8m)	750/500	238 sf (22.1 sm)
Corner Roll	9.5 oz/sy (238 g/sm)	9.5" x 150' (96.5cm x 45.7m)	274/274	150 lf (45.7 m)

*Allow about 10% waste for lapping all meshes (Strong, Ultra and Corner Roll Meshes are butted). Coverage will vary.

Mesh Types

Detail Mesh – super soft, pliable mesh used for backwrapping, special shapes, and detail work.

Standard Mesh – Standard weight mesh for wall areas and general detailing.

Hi-Tech Mesh – Upgraded heavier weight version of *Standard Mesh* with good workability.

Medium Mesh – Extra tough heavy weight mesh. Best for areas of light traffic.

Strong Mesh – Great high traffic mesh where impacts are a consideration.

Ultra Mesh – Best where abuse is expected. Ultra heavy for high traffic areas.

Strong Mesh and Ultra Mesh must be used in a two-layer system with Standard Mesh, Hi-Tech Mesh, or Medium Mesh.

Corner Roll– For highly impact resistant corners. Apply under Standard or higher mesh.

Application Procedure

Job Conditions - Air and substrate temperature for application of the *Reinforcing Mesh* must be 40°F (5°C) or higher and must remain 40°F (5°C) or higher for a minimum of 24 hours. Provide temporary protection at all times until the wall system, including flashings, caps, and sealants, is completed to provide protection from climatic conditions and other potential damage.

Application - All imperfections in the insulation board must be rasped flush and any gaps in the insulation board must be filled with slivers of insulation. Apply the base coat over the entire surface of the insulation board in a thickness greater than that of the *Reinforcing Mesh* being used, approximately 1/16" (1.6 mm) for Standard Mesh and 3/32" (2.4 mm) for Ultra Mesh. Immediately embed the *Aggre-flex Mesh* into the wet base coat and smooth from the center to the edge to avoid wrinkles. Lap all meshes except Strong Mesh and Ultra Mesh a minimum of 2-1/2" (63.5 mm) on all sides. The reinforcing fabric must be continuous at all corners and lapped or abutted in accordance to Master Wall specifications. The color of the mesh shall not be visible but a slight mesh pattern may be visible. The overall minimum thickness of the base coat should be a nominal 1/16" (1.6 mm) when dry.

When applying **Strong, Ultra or Corner Roll Mesh**, tightly abut all edges and let cure for a minimum of 12 hours. Grind any imperfections with the edge of a stainless steel trowel or grinding stone, taking care not to damage the *Aggre-flex Mesh*, and apply a layer of **Standard Mesh, Hi-Tech Mesh, or Medium Mesh** as per the directions in the preceding paragraph. To minimize wall variations, the lap of the second mesh layer should not coincide with the abutment of the first layer.

Special Conditions and Recommendations

Apply backwrapping mesh or other approved accessory at all terminations of the insulation board. This includes at the top and bottom of all walls and at all openings.

Aggre-flex Mesh may be wrapped from the face of the insulation board onto a foundation or onto the studs of an opening on barrier wall systems. In all cases, the exposed edges of the insulation board must be wrapped with *Aggre-flex Mesh* and base coat or an approved accessory trim.

Impact ASTM E2486 (Formerly EIMA 101.86)		
Standard Mesh	Medium Impact Resistance	50-89 in-lbs (5.7-10.1J)
Hi Tech Mesh	Medium Impact Resistance	50-89 in-lbs (5.7-10.1J)
Medium Mesh	Medium Impact Resistance	50-89 in-lbs (5.7-10.1J)
Medium & Standard	High Impact Resistance	90-150 in-lbs (10.2-17.0J)
Strong & Standard	High Impact Resistance	90-150 in-lbs (10.2-17.0J)
Ultra & Standard	Ultra High Impact Resistance	150+ in-lbs (over17.0J)



Information contained in this product data sheet conforms to the standard detail recommendations and specifications for the installation of Master Wall Inc. products and is presented in good faith. Master Wall Inc. assumes no liability, expressed or implied as to the architecture, engineering, or workmanship of any project. This information may be concurrent with, or superseded by other applicable documents, such as specifications and details. Contact Master Wall Inc. for the most current product information.

P. O. Box 397
Fortson, GA 31808
800-755-0825
Technical 800-760-2861
masterwall.com

Insulation Board

Manufactured for Master Wall Systems Molded Expanded Polystyrene

Master Wall Insulation Board is a high performance insulation material that is used to wrap the entire building to keep interior temperatures more consistent. It helps to reduce thermal bridging at framing members and is easy to cut, rasp and place. It may be custom formed into various decorative shapes. Packaged in 144 board foot bundles, each bundle weights approximately 12 lbs (5.44 kg) and is available in flat or drainage configurations.

Properties

Meets or Exceeds:

ASTM C578, C273, D1623, E2430, E2568

Classification: Type I

Density, lb/ft³ (kg/m³):

0.95 (15.2) min., 1.25 (20.0) max.

Thermal Resistance per inch (25.4mm) thickness, min. Ft².h/Btu (K*m²/W):

@40°F (4.4°C) 4.00 (0.70)

@75°F (23.9°C) 3.60 (0.63)

Compressive strength, min., PSI (kPa): 10.0 (69)

Tensile strength min., PSI (kPa): 15.0 (103)

Flexural Strength, min., PSI (kPa) : 25.0 (172)

Shear modulus, max., PSI (kPa): 400 (2758)

Water Vapor Permeance of 1.00 in (25.2 mm) thickness, max., perm (ng/Pa.s.m²): 5.0 (2.87)

Water absorption by total immersion, max., volume, % : 2.5

Dimensional stability (change in dimensions), max., %: 2.0

Oxygen index, min., volume, %: 24.0

Flame spread, max.: 25.0

Smoke development, max. 450

Board thickness:

Maximum 4" (102mm)

Minimum 3/4" (19.1mm)

Drainage Board min. 1-1/2" (38.2 mm)

Board width, max.: 24" (610mm)

Board length, max.: 48" (1219mm)

Estimated Coverage by Thickness

Varies by manufacturer facility:

- **3/4" (19.2 mm):** 24 pcs, 192 sf (17.84 sm)
- **1" (25.2 mm):** 18 pcs, 144 sf (13.38 sm)
- **1-1/2" (38.2 mm):** 12 pcs, 96 sf (8.92 sm)
- **2" (50.8 mm):** 9 pcs, 72 sf (6.69 sm)
- **3" (76.2 mm):** 6 pcs, 48 sf (4.46 sm)
- **4" (101.6 mm):** 5 pcs, 40 sf (3.72 sm)

Application Procedure

Job Conditions - Follow directions on adhesive data sheets. Mechanical attachment of insulation boards may be performed at lower temperatures over a dry surface.

Temporary Protection – Provide temporary and permanent protection to prevent water entry behind the system.

Substrate Preparation – Applications must be to an approved substrate with a maximum variation tolerance of 1/4" in 10'-0" (6.4 mm in 3.05m). Contact Master Wall for approved substrates and recommended attachment methods.

Application

The *Insulation Board* can be easily cut using handsaws, power saws, sharp knives, or thermal cutting tools. Rasping of the Insulation Board is completed with 12 grit sandpaper, manually or with air or electric rasping machines.

Follow data sheet recommendations for adhering insulation board to approved substrates. For mechanical attachment, fasten the *Insulation Board* to the approved substrate using Wind-Lock Wind-Devil 2 retainers. See Master Wall System Details for more information. Fastening patterns shall be determined by the requirements of the geographical conditions of the area, local code requirements, and the performance of the fasteners, retainers and their test results in conjunction with the specified substrate and the thickness of MEPS specified for use. Minimum 1" (25.2 mm) thickness for mechanically attached systems.

Install insulation board on the wall according to specification requirements. For further information and details, see the Master Wall System Application Instructions.

Limitations

- The minimum required thickness for MEPS in the Master Wall Aggre-flex PB EIF System is 3/4" (19.2 mm) at any location on the wall.
- The maximum thickness for MEPS is 4" (102 mm) as set by most building code agencies for noncombustible construction.
- MEPS shall not be used in interior applications.
- Residential applications require a secondary water barrier and mechanical attachment with the option of flat or drainage insulation board. See Aggre-flex Drainage Details for insulation board construction.



Information contained in this product data sheet conforms to the standard detail recommendations and specifications for the installation of Master Wall Inc. products and is presented in good faith. Master Wall Inc. assumes no liability, expressed or implied as to the architecture, engineering, or workmanship of any project. This information may be concurrent with, or superseded by other applicable documents, such as specifications and details. Contact Master Wall Inc. for the most current product information.

P. O. Box 397
Fortson, GA 31808

800-755-0825

Technical 800-760-2861

masterwall.com

WeatherStop



WeatherStop is a flexible, fibered 100% pure acrylic trowel applied air and water barrier for use with Master Wall Systems. WeatherStop is available in five-gallon (19L) pails and is mixed 1:1 with Portland cement to a creamy consistency.

Air & Water Barrier Trowel Applied

Application Procedure

Job Conditions - Air and substrate temperature for application of *WeatherStop* must be 40° F (5°C) or higher and must remain 40°F (5°C) or higher for a minimum of 24 hours. Provide temporary protection to protect the wall system from damage until permanent flashings, caps and sealants are installed. Store materials within prescribed temperature limits and out of direct sunlight. Working and drying times are based upon normal room temperature conditions and will vary with temperature and humidity.

Preparation - The substrate must be approved by Master Wall Inc., clean, dry, structurally sound and free of efflorescence, oil, grease, form release agents and curing compounds or anything that would affect bond. Painted surfaces are not acceptable and must be removed.

Mixing - Thoroughly stir *WeatherStop* using a heavy duty 1/2" (12.7 mm) drill at 400 - 500 rpm and a heavy duty mixing paddle. Pour half of the stirred *WeatherStop* into a clean plastic pail. Up to 12 ounces (0.35L) of clean, potable water may be added to adjust workability. Add Type I or I-II Portland cement to the half pail of *WeatherStop* in a ratio of one-to-one by weight and mix to a homogenous consistency. Let the mixture stand for 3 to 5 minutes and then stir to a creamy consistency. Do not exceed 24 ounces (0.7L) per pail. Do not over mix as faster setting or reduced working time can occur. Do not add accelerators or retarders to the *WeatherStop* mixture.

Application

For sheathing substrates—Apply one of the sheathing board joint reinforcing methods noted below:

- Apply 4" (102 mm) Master Wall *Self-Adhesive Mesh* over the sheathing board joints or embed 4" (102 mm) minimum wide *Master Wall Standard or Detail Mesh* in *WeatherStop*. Cover all joints with an initial coating of *WeatherStop* and allow to dry to the touch.
- Prime joints with *BA57* and allow to dry to the touch. Apply 4" (102 mm) *WeatherStop Tape* on the sheathing board joints.

Water barrier application – Apply the *WeatherStop* mixture over the entire surface of the approved substrate in a thickness of approximately 1/16" (1.6 mm). Allow to cure completely before proceeding the Aggre-flex or Aggre-flex Commercial Drainage EIFS or other approved applications.

Clean Up—Tools and equipment can be cleaned with soapy water while the *WeatherStop* is still wet.

Statistics

Coverage (Estimated/varies)

1/16" (1.6 mm) thick: 160-200 sf (15-18.6 sm)

Pail Weight: 60 lbs (27kg)

Working Time: 1 hour @ room temperature

Drying Time: 12 hours @ room temperature

Application Range: 40°-110°F (5°-43°C)

Exposure: 30 days maximum

Shelf Life: 2 years



Information contained in this product data sheet conforms to the standard detail recommendations and specifications for the installation of Master Wall Inc. products and is presented in good faith. Master Wall Inc. assumes no liability, expressed or implied as to the architecture, engineering, or workmanship of any project. This information may be concurrent with, or superseded by other applicable documents, such as specifications and details. Contact Master Wall Inc. for the most current product information.

P. O. Box 397
Fortson, GA 31808
800-755-0825
Technical 800-760-2861
www.masterwall.com



WeatherStop Tapes



WeatherStop Tapes are a peel and stick type flashing with self-

Peel & Stick Flashing

sealing properties and a polyester scrim facing designed for use with Master Wall Systems. The tapes feature low initial grab for repositioning that gradually increases over time.

Tape Sizes

WeatherStop Tapes are available in the following size rolls:

- 4"x100' (10.2cm x 30.5m)
- 6"x100' (15.2cm x 30.5m)
- 12"x100' (30.5cm x 30.5m)

Weight & Packaging

Weather Stop Flashing Tape is packaged in cases weighing 82 lbs (37.2kg).

4" (10.2cm) Wide:

- 12 rolls/case
- 18 cases/pallet

6" (15.2 cm) Wide:

- 8 rolls/case
- 18 cases/pallet

12" (30.5 cm) Wide:

- 4 rolls/case
- 18 cases/pallet

Application Procedure

General—The substrate must be clean, dry, structurally sound and free of efflorescence, oil, grease, form release agents and curing compounds. Painted surfaces are not acceptable and the paint must be removed.

Job Conditions - Air and substrate temperature for application of WeatherStop Tapes must be 40°F (5°C) or higher.

Temporary Protection - Do not expose to direct sunlight for more than six weeks after installation.

Surface Preparation - Surface temperature must be above 40°F (5°C). Surface must be cured, clean, dry, structurally sound and free of efflorescence, oil, grease, form release agents, and curing compounds.

Approved Substrates—Include Exterior gypsum sheathing (ASTM C79), Dens Glass Gold®, GlasRoc®, FiberBond®, Durock®, PermaBase®, Concrete, Brick, Masonry, Wood, Exterior Plywood, Oriented Strand Board and Metal. Contact Master Wall for other approved substrates.

Priming - Prime all surfaces except metal with BA57 and allow to dry to the touch.

Installation - Plan the work from the bottom up in a shingle-fashion installation. Size the piece of flashing so that it is easy to handle. Start by removing about 12 inches (305 mm) of the release paper and placing it over the area being sealed. Firmly press WeatherStop Tape into place, rolling out any bubbles and smoothing it into the surface. Continue pulling off the release paper and smoothing the tape into place.

Limitations

WeatherStop Tape is a vapor barrier. The dew point must be engineered if it is used as a continuous air/water barrier.

Window Flashing Application

Weather Resistive barrier (not shown) is placed over head flashing and under jamb and sill flashing.

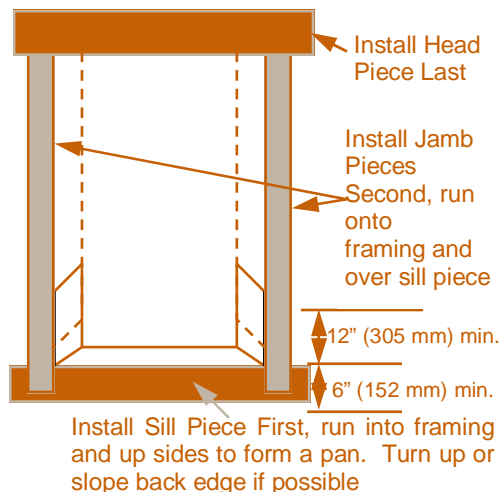

Sheathing Application

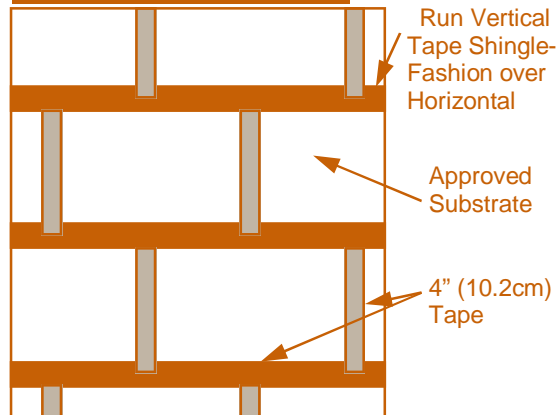

Information contained in this product data sheet conforms to the standard detail recommendations and specifications for the installation of Master Wall Inc. products and is presented in good faith. Master Wall Inc. assumes no liability, expressed or implied as to the architecture, engineering, or workmanship of any project. This information may be concurrent with, or superseded by other applicable documents, such as specifications and details. Contact Master Wall Inc. for the most current product information.

P. O. Box 397
Fortson, GA 31808
800-755-0825
Technical 800-760-2861
www.masterwall.com



Section 07 24 19

*Corporate • P.O. Box 397 • Fortson • Georgia • 31808 • 800-755-0825 • FAX 706-569-6704
Technical • 800-760-2861 • FAX 734-433-0930*

Part 1 General

1.01 SECTION INCLUDES

- A. Exterior Insulation and Finish System (EIFS) Class PB as defined by EIFS Industry Members Association (EIMA) with a trowel-applied water barrier and peel and stick flashings.
- B. Molded Expanded Polystyrene (MEPS) Insulation Board.

1.02 SCOPE OF WORK

- A. Provide all materials, labor, and equipment to install the Field Applied and/or Panelized Master Wall Inc. Aggre-flex Commercial Drainage Exterior Insulation and Finish System (EIFS).
- B. Related Sections:
 - 1. Concrete 03300
 - 2. Unit Masonry 04200
 - 3. Light Gauge Steel Framing 05400
 - 4. Sheathing 06100
 - 5. Sheet Metal Flashing and Trim 07620
 - 6. Sealants 07900
 - 7. Doors and Windows 08000

1.03 REFERENCES

- A. ASTM Standards
 - 1. ASTM B-117 (Federal Test Standard 141A Method 6061) Salt Spray Fog Test Method
 - 2. ASTM C-67 Method of Sampling and Testing Brick and Structural Clay Tile
 - 3. ASTM C-79 Test Method for Gypsum Sheathing
 - 4. ASTM C-150 Specification for Portland Cement
 - 5. ASTM C-578 Specification for Preformed Cellular Polystyrene Thermal Insulation
 - 6. ASTM C-1177 Specification for Glass Mat Gypsum Substrate for Use as Sheathing
 - 7. ASTM D-897 (Modified) Bond Strength Before and After 2000 Hours Fluorescent UV-Condensation Type Weathering (QUV Weatherometer)
 - 8. ASTM D-2247 (Federal Test Standard 141A Method 6201) Method of Testing Metal Specimens at 100 Percent Relative Humidity
 - 9. ASTM E-72 Transverse Load Test Method
 - 10. ASTM E-84 Test Method of Surface Burning Characteristics of Building Materials
 - 11. ASTM E-96 Test Method for Water Vapor Transmission of Materials
 - 12. ASTM E-108 (Modified) Method for Fire Tests of Roof Coverings
 - 13. ASTM E-330 Test Method for Structural Performance of Exterior Windows, Curtain Walls, and Doors by Uniform Static Air Pressure Difference
 - 14. ASTM E-331 Test method for Water Penetration of Exterior Windows, Curtain Walls and Doors by Uniform Static Air Pressure Difference
 - 15. ASTM G-23 (Federal Test Standard 141A Method 6151) Recommended Practice for Operating Light and Water Exposure Apparatus (Carbon-Arc Type) for Exposure of Non-metallic Materials
 - 16. ASTM G-53 Recommended Practice for Operating Light-and Water-Exposure Apparatus (Fluorescent UV-Condensation Type) for Exposure of Non-metallic Materials



Section 07 24 19

Corporate • P.O. Box 397 • Fortson • Georgia • 31808 • 800-755-0825 • FAX 706-569-6704
Technical • 800-760-2861 • FAX 734-433-0930

- B. Other Test Methods and Reference Documents
 1. BOCA Radiant Panel Test Method for Ignitibility Characteristics of Exterior Wall Systems
 2. ICBO Freeze Thaw Test Method
- C. EIMA Standards and Documents
 1. EIMA 101.86 Standard Test Method for Resistance of Exterior Insulation and Finish Systems (EIFS), Class PB, to the Effects of Rapid Deformation (Impact)
 2. EIMA 105.01 Standard Test Method for Alkali Resistance of Glass Fiber Reinforcing Mesh for Use in Exterior Insulation and Finish Systems (EIFS), Class PB
 3. EIMA Guide for use of Sealants with Exterior Insulation and Finish Systems (EIFS), Class PB
 4. EIMA Guideline Specification for Exterior Insulation and Finish Systems (EIFS), Class PB
 5. EIMA Guideline Specification for Expanded Polystyrene (EPS) Insulation Board
- D. Building Code Standards
 1. Section 1406.0, 1996 National Building Code, Building Officials and Code Administrators International (BOCA)
 2. Section 717.4 and 717.5, 1994 Standard Building Code, Southern Building Code Congress International (SBCCI)
 3. UBC Standard 26-4 (formerly UBC 17-6), 1994 Uniform Building Code, International Conference of Building Officials (ICBO)

1.04 TERMS / DEFINITIONS

- A. Applicator – The contractor that applies the EIFS.
- B. Adhesive – A cementitious material used to attach the insulation board to the substrate.
- C. Aesthetic Joint – A groove in the MEPS designed to create aesthetics and used to provide starting and stopping points during the application of the finish coat. A minimum ¼" thickness of MEPS shall remain below the deepest point in the aesthetic groove. Aesthetic joints are not expansion or control joints nor should they be used in lieu of expansion or control joints.
- D. Backwrapping – The application of the reinforced base coat on the exposed edge of the MEPS and a minimum of 2 ½" on each face of the MEPS.
- E. Base Coat – The material applied to the face of the insulation board and reinforced with one or more layers of mesh to function as the weather barrier.
- F. Base Coat Mixture – A field mixed blend of base coat and Portland cement.
- G. Building Expansion Joint – A joint through the entire building structure designed to accommodate structural movement.
- H. Class PB System – A class of EIFS where the base coat varies in thickness depending upon the number of layers, or thickness, of reinforcing material. The reinforcing material is glass fiber mesh, which is embedded into the base coat per EIFS manufacturer's recommendations and with no mesh color visible. Protective finish coats, of various thicknesses, in a variety of textures and colors, are applied over base coat.
- I. Designer – The person or firm that is responsible to create the plans and specifications for the entire project.
- J. EIFS – Exterior Insulation and Finish System
- K. EIMA – EIFS Industry Members Association



Section 07 24 19

Corporate • P.O. Box 397 • Fortson • Georgia • 31808 • 800-755-0825 • FAX 706-569-6704
Technical • 800-760-2861 • FAX 734-433-0930

- L. Expansion Joint – A designed joint in the continuity of a material, assembly, or system, designed to accommodate movement.
- M. Finish Coat – An acrylic based, factory mixed decorative and protective coating that is applied to the base coat.
- N. Insulation Board – Molded Expanded Polystyrene Board, manufactured in accordance with the EIFS manufacturer's specifications, attached to the substrate and covered with the reinforced base coat and finish.
- O. MEPS – Molded Expanded Polystyrene Board, manufactured in accordance with the EIFS manufacturer's specifications, attached to the substrate and covered with the reinforced base coat and finish.
- P. Reinforcing Mesh – Balanced, open weave, basic glass fiber mesh(es) supplied by the manufacturer of the EIFS, treated for compatibility with other materials of the system, which functions to strengthen the system and adds impact resistance.
- Q. Mechanical Fastener – Typically a plastic washer and a mechanical fastener utilized to attach the insulation board to the substrate.
- R. Sheathing – A substrate in a sheet form.
- S. Substrate – The material to which the EIFS is attached.

1.05 QUALITY ASSURANCE

A. Design and Detailing

1. General

- a. Master Wall Inc.'s current published details, specifications, data sheets, technical bulletins and other literature/information are minimum standards and guidelines that shall be followed when designing and detailing a project with the Aggre-flex Commercial Drainage EIF System.
- b. Details shall conform to Master Wall Inc.'s details and shall be consistent with the project requirements.
- c. Master Wall Inc. must approve deviations from the standard published details in writing.
- d. The architect, engineer or the designer of the project should determine where the dew point would occur in relationship to the wall assembly and the project location during summer and winter conditions.
- e. Drip details shall be specified in accordance with Master Wall Inc.'s published details.
- f. At all locations the reinforced base coat or the substrate shall encapsulate the approved insulation board.
- g. The minimum slope of inclined surfaces shall not be less than 6" (152mm) in 12" with a maximum length of 12" unless approved in writing by Master Wall Inc. Inclined surfaces which are or could be defined as roofs by the building codes or application are not approved by Master Wall Inc.
- h. The use of dark colors must be considered in relation to wall surface temperature as a function of local climatic conditions.
- i. The MEPS shall be separated from the interior of the building by a 15-minute thermal barrier.
- j. The use and maximum thickness of MEPS shall be in accordance with the applicable building codes.
- k. The EIF System shall be recognized by the following Model Code Organizations: BOCA, ICBO, SBCCI



Section 07 24 19

Corporate • P.O. Box 397 • Fortson • Georgia • 31808 • 800-755-0825 • FAX 706-569-6704
Technical • 800-760-2861 • FAX 734-433-0930

- I. It is the responsibility of the architect and the purchaser to determine if a product is suitable for their intended use. The architect or designer of the project shall be responsible for all decisions pertaining to the design, details, structural capability, attachment details, shop drawings and the like. Master Wall Inc. has prepared specifications, details and data sheets to assist as guidelines for the use and installation of the products. Master Wall Inc. is not responsible for the design, details, structural capability, attachment details and shop drawings whether it is based on Master Wall Inc.'s information or not.
2. Substrate
 - a. The maximum deflection under full flexural design loads of the substrate system shall not exceed L/240.
 - b. Acceptable substrates for Aggre-flex Commercial Drainage EIFS include unpainted brick, unit masonry, concrete, stucco brown coat, exterior grade gypsum sheathing (ASTM C-79 or ASTM C-1177), and approved cementitious sheathings.
 - c. Substrates not approved in the manufacturer's published literature shall be approved by the manufacture in writing prior to the application or the system.
 - d. The project architect or engineer shall engineer the substrate with regard to the required structural performance.
3. Expansion joints
 - a. Expansion joints shall be installed in the EIFS a maximum of every 75 lineal feet. Reference construction documents for specific locations.
 - b. Expansion joints in the system are required at building expansion joints, at prefabricated panel joints, where substrates change, at floor lines in wood framed construction, and where structural movement is anticipated.
4. Aesthetic Joints
 - a. Aesthetic joints may be installed to provide sufficient break points in the EIF System to prevent cold joints from occurring in the finish coat.
 - b. Aesthetic joints shall not be used in lieu of an expansion or control joint.
5. Sealants
 - a. Sealants and backer rod, as required at expansion joints and dissimilar substrates, shall provide a complete watertight system.
 - b. The sealants in an EIFS expansion joint, or any sealant joint that anticipates significant movement, shall be bonded to the reinforced base coat, not the finish coat. The color of the mesh shall not be visible and the texture of the mesh shall not be exposed within base coat at these locations.
 - c. All penetrations through the system such as hose bibs, dryer vents, lighting fixtures, air-conditioning hoses, etc. must be properly sealed to insure the integrity of the system.
6. Flashings
 - a. When wood framed construction is used, sill pans with three sided end dams shall be installed prior to window frame installation and designed to collect and direct water to the exterior of the reinforced base and finish coat.
 - b. Metal flashing shall be installed at heads of openings.
 - c. Continuous metal flashing shall be installed at heads of ganged windows.
 - d. Flashing shall be installed at rooflines in a manner to prevent any intrusion of water behind the EIFS. This shall include the use of roof kick-out flashing at roof terminations.
 - e. When the EIFS is applied to the chimney, a chimney cricket shall be installed.
 - d. Wooden decks must be flashed before system is installed. Refer to Master Wall Inc.'s details.



Section 07 24 19

*Corporate • P.O. Box 397 • Fortson • Georgia • 31808 • 800-755-0825 • FAX 706-569-6704
Technical • 800-760-2861 • FAX 734-433-0930*

B. Qualifications

1. The EIFS Manufacturer shall have manufactured Exterior Insulation and Finish Systems in the United States for at least 10 years.
2. The Applicator shall be knowledgeable in the proper installation of the Master Wall Inc. Aggre-flex Commercial Drainage EIF System.
3. The Applicator shall have demonstrated the ability to install the system on projects of similar size and complexity.
4. The Applicator shall provide the proper equipment, manpower and supervision on the job site to install the system in compliance with project plans and specifications.
5. The Insulation Board Manufacturer shall be approved by Master Wall Inc. to produce MEPS in accordance with Master Wall Inc.'s specifications.
6. The sealant contractor shall be experienced in the installation of high performance industrial and commercial sealants.
7. Prior to the installation of the Aggre-flex Commercial Drainage EIF System, erect sample wall mock-up using materials and joint details required for final work. Provide special features as directed for sealant and contiguous work. Build mock-up at the site where directed of full thickness, indicating the proposed color, texture, and workmanship to be expected in the completed work. Obtain architect's acceptance of the mock-up in regard to aesthetic quality before start of work. Retain mock-up during construction as a standard for judging completed work. Do not alter, move, or destroy mock-up until work is completed, and until final acceptance of the project by architect.

1.06 SUBMITTALS

- A. The Applicator shall submit a list of completed projects of like size and complexity.
- B. The Applicator shall submit a certificate of training indicating that they have been given instructions on the proper installation of the EIF System.
- C. The Applicator shall submit EIFS Manufacturer's current literature, brochures, specifications, and details.
- D. The Applicator shall submit sufficient samples of each finish texture and color selected. The samples shall be prepared with the same tools and techniques required for the actual project. Color and texture should be approved based on the job site mock-up samples.
- E. The Applicator shall provide any shop drawings that may be applicable to the project for approval by the project architect.

1.07 DELIVERY, STORAGE AND HANDLING

- A. Deliver all materials in original unopened packages with labels intact. Verify all quantities, colors, and textures against bill of lading.
- B. Store all materials protected from direct exposure to weather conditions and at temperatures not less than 40° F (4° C) or greater than 110° F (43° C).
- C. Stack insulation board flat, fully supported off the ground and protected from direct exposure to the sun.
- D. Material safety data sheets (MSDS) shall be supplied for the components of the EIFS and be available at the job site.



Section 07 24 19

Corporate • P.O. Box 397 • Fortson • Georgia • 31808 • 800-755-0825 • FAX 706-569-6704
Technical • 800-760-2861 • FAX 734-433-0930

1.08 JOB CONDITIONS

- A. Ambient air temperatures shall be 40° F (5° C) or greater and rising at the time of installation of the Master Wall Inc. products and shall remain at 40° F (5° C) or greater for at least 24 hours after application.
- B. Provide supplemental heat and protection as required when the temperature and conditions are not in accordance with installation requirements. Sufficient ventilation and time shall be provided to ensure that materials have sufficiently dried prior to removing supplemental heat.
- C. Adequate protection shall be provided to prevent weather conditions (humidity, temperature, and precipitation) from having an affect on the curing or drying time of Master Wall Inc. materials.
- D. Adjacent materials and the Aggre-flex System shall be protected during installation and while curing from weather and shall be protected from site damage.
- E. Coordinate installation of the Aggre-flex System with related work specified in other sections to ensure that the wall assembly is protected to prevent water from getting behind the system. The cap flashing shall be installed as soon as possible after the finish coat has been applied. When this is not possible, temporary protection shall be provided immediately in this area.
- F. All sealants shall be installed in a timely manner. Protect open joints from water intrusion during construction with backer rod, or temporary covering, until permanently sealed.
- G. Sufficient manpower and equipment shall be employed to ensure a continuous operation, free of cold joints, scaffolding lines, texture variations, etc.

1.09 REPAIR AND MAINTENANCE

- A. Refer to Master Wall Inc. specific repair and maintenance procedures.
- B. Sealants and Flashings shall be inspected annually to verify that the products are not allowing water intrusion. If sealant and/or flashing are allowing water intrusion, repairs should be made immediately.

1.10 LIMITED MATERIALS WARRANTY

- A. A Limited Materials Warranty shall be issued upon the receipt of a properly completed warranty request form.

PART 2 PRODUCTS

2.01 GENERAL

- A. All components of the Aggre-flex Commercial Drainage EIF System shall be obtained from Master Wall Inc. or its authorized distributors. No substitutions of, or additions of, other materials shall be submitted without prior written permission from Master Wall Inc. Substitutions or additions will void the warranty.

2.02 MATERIALS

- A. Adhesives
 - 1. Master Wall Inc. Foam & Mesh (F&M) Adhesive: An acrylic-based product mixed one-to-one by weight with Portland cement for use as the adhesive to bond insulation board to an approved substrate.
 - 2. F & M Plus: An acrylic-based product mixed one-to-one by weight with Portland cement designed for use as the adhesive to bond insulation board to an approved substrate.
- B. Air/Water Barrier
 - 1. WeatherStop: A flexible polymer-based, fiber-reinforced air barrier and waterproof membrane that is mixed 1:1 with Portland cement.



Section 07 24 19

Corporate • P.O. Box 397 • Fortson • Georgia • 31808 • 800-755-0825 • FAX 706-569-6704
Technical • 800-760-2861 • FAX 734-433-0930

2. WeatherStop Mesh: A 4" (102 mm) self-adhesive mesh formulated for compatibility with WeatherStop. Used at sheathing board joints.
 3. WeatherStop Sheathing Tape: A self-adhesive highly flexible air, water and vapor barrier used as an alternate to WeatherStop Mesh (required in ICBO jurisdictions). Prime with Primer 57. Used at sheathing board joints.
- C. Flashing
1. WeatherStop Tapes: A self-adhesive moisture barrier for sealing penetrations in the Aggre-flex Commercial Drainage EIFS. Available in 4" (102 mm), 6" (152 mm) and 12" (305 mm) sizes. Prime with BA57.
- D. Insulation Board
1. Insulation Board shall meet or exceed ASTM C-578 and Master Wall Inc.'s requirements for MEPS.
 2. Nominal 1.0 pcf, aged expanded polystyrene.
 3. Flamespread and smoke development shall be 25 and 450 or less respectively per ASTM E-84.
 4. Maximum size 2'x4'x4". Refer to actual contract documents to determine actual insulation board thickness.
- E. Reinforcing Mesh
- Open weave glass fiber fabric, treated for alkaline resistance and compatibility with Master Wall Base Coats, and conforming ASTM D-76, D-579, D-5035, MIL-Y-1140 and meeting a minimum Medium Impact Resistance (50-89 in-lbs) when tested to EIMA 101.86 Impact Resistance Standards.
1. Detail Mesh – nominal 4.5 oz./sq. yd.
 2. Standard Mesh – nominal 4.5 oz./sq. yd.
 3. Hi-Tech Mesh – nominal 6.0 oz./sq. yd.
 4. Medium Mesh – nominal 10.4 oz./sq. yd.
 5. Strong Mesh – nominal 15.4 oz./sq. yd.
 6. Ultra Mesh – nominal 21 oz./sq. yd.
- F. Base Coats
1. Master Wall Inc. Foam & Mesh (F&M) Adhesive: An acrylic-based product mixed one-to-one by weight with Portland cement designed for use with reinforcing mesh as the base coating over the insulation board.
 2. Master Wall Bagged Base Coat (MBB): A polymer based cementitious product mixed with 5 to 6 quarts of water for use as an adhesive and base coating over the insulation board.
 3. F&M Plus: An acrylic-based product mixed one-to-one by weight with Portland cement designed for use with reinforcing mesh as the base coating over the insulation board. (This product shall be used where indicated on the construction drawings when a leveling base coat is required.)
- G. Water Resistant Adhesive & Base Coat
1. Guardian – An acrylic-based product mixed one-to-one by weight with Portland cement for use as the adhesive to bond insulation board to an approved substrate and/or as a base coat with reinforcing mesh over insulation board. (This product should be used as designated on the construction drawings where additional resistance to moisture is needed.)



Section 07 24 19

*Corporate • P.O. Box 397 • Fortson • Georgia • 31808 • 800-755-0825 • FAX 706-569-6704
Technical • 800-760-2861 • FAX 734-433-0930*

- H. Finish: Master Wall Inc.'s Superior Finishes are acrylic-based wall coatings available in a variety of colors and textures. The following textures are available:
1. Perfect - rilled texture
 2. Spray – sand type texture
 3. R-Coarse – coarse rilled texture
 4. Desert Sand – coarse sand texture
 5. Refinish – Fine texture used to create numerous finishes
 6. Aggre-flex Superior Stone Finish – clear acrylic matrix filled with colored ceramic beads

Note: The above textures excluding Superior Stone and Aggrestone Finishes are also available in the Aggre-flex Superior Silicone Coat product line and the Aggre-flex Superior Elastomeric Coat product line. Aggre-flex Superior Silicone Coat combines acrylic and the siloxane polymers to provide the maximum resistance to moisture. Aggre-flex Superior Elastomeric Coat utilizes elastomeric polymers to enable the finishes to bridge minor cracking.

- I. Water: Shall be clear, clean and potable without any foreign matter in the solution, which may affect the color and setting qualities of the cement, adhesive, base or finish coat.
- J. Cement: Type I or I-II Portland cement meeting ASTM C-150.
- K. Weep Screed: #WS58-250 by Vinyl Corp., #631-75 by Plastic Components or Master Wall approved equal.
- L. Sealant Systems: Reference Sealant Specification, Section 07900.

PART 3 EXECUTION

3.01 EXAMINATION

- A. Prior to installation of the Aggre-flex Commercial Drainage System, the contractor shall verify that the substrate:
1. Is of a type listed in Section 1.04.C.1.
 2. Is flat within 6.4 mm (1/4 in) in a 1.2 m (4 ft) radius.
 3. Is sound, dry, connections are tight, has no surface voids, projections or other conditions that may interfere with the Aggre-flex Commercial Drainage System installation or performance.
- B. Prior to the installation of the Aggre-flex Commercial Drainage System, the architect or general contractor shall insure that all needed flashings and other waterproofing details have been completed, if such completion is required prior to the Aggre-flex Commercial Drainage application. Additionally, the Contractor shall ensure that:
1. Metal roof flashing has been installed in accordance with Asphalt Roofing Manufacturers Association (ARMA) Standards.
 2. Openings are flashed in accordance with the Aggre-flex Commercial Drainage System Installation Details or as otherwise necessary to prevent water penetration.
 3. Chimneys, Balconies, and Decks have been properly flashed.
 4. Windows, Doors, etc. are installed and flashed per manufacturer's requirements and the Aggre-flex Commercial Drainage System Installation Details.



Section 07 24 19

*Corporate • P.O. Box 397 • Fortson • Georgia • 31808 • 800-755-0825 • FAX 706-569-6704
Technical • 800-760-2861 • FAX 734-433-0930*

C. Prior to the installation of the Aggre-flex Commercial Drainage System, the contractor shall notify the general contractor, and/or architect, and/or owner of all discrepancies.

3.02 PREPARATION

A. The Aggre-flex Commercial Drainage materials shall be protected by permanent or temporary means from inclement weather and other sources of damage prior to, during, and following application until completely dry.

B. Protect adjoining work and property during Aggre-flex Commercial Drainage installation.

C. The substrate shall be prepared as to be free of foreign materials, such as, oil, dust, dirt, form release agents, efflorescence, paint, wax, water repellents, moisture, frost and any other condition that inhibit adhesion.

3.03 INSTALLATION

A. The system shall be installed in accordance with the current Master Wall Inc. Aggre-flex Commercial Drainage System Application Instructions.

B. The overall minimum base coat thickness shall be sufficient to fully embed the mesh.

C. Sealant shall not be applied directly to textured finishes.

D. When installing the Aggre-flex Commercial Drainage System, adhere according to Master Wall Inc. and local requirements.

E. High impact meshes shall be installed as specified at ground level, high traffic areas and other areas exposed to or susceptible to impact damage.

3.04 FIELD QUALITY CONTROL

A. The contractor shall be responsible for the proper application of the Aggre-flex Commercial Drainage materials.

B. Master Wall Inc. assumes no responsibility for on-site inspections or application of its products.

C. If required, the contractor shall certify in writing the quality of work performed relative to the substrate system, details, installation procedures, workmanship and as to the specific products used.

D. If required, the EPS supplier shall certify in writing that the EPS meets Master Wall Inc.'s specifications.

E. If required, the sealant contractor shall certify in writing that the sealant application is in accordance with the sealant manufacturer's and Master Wall Inc.'s recommendations.

3.05 CLEANING

A. All excess Aggre-flex Commercial Drainage System materials shall be removed from the job site by the contractor in accordance with contract provisions and as required by applicable law.

B. All surrounding areas, where the Aggre-flex Commercial Drainage System has been installed, shall be left free of debris and foreign substances resulting from the contractor's work.

3.06 PROTECTION

A. The Aggre-flex Commercial Drainage System shall be protected from inclement weather and other sources of damage until dry and permanent protection in the form of flashings, sealants, etc. are installed.

Disclaimer

This Specification is published for general informational purposes only and is not intended to imply that these are the only materials, procedures, or methods, which are available or suitable. Materials, procedures, or methods may vary according to the particular circumstances, local building code requirements, design conditions, or statutory and regulatory requirements. While the information in this specification is believed to be accurate and reliable, it is presented without guarantee or responsibility on the part of Master Wall Inc.



Commercial Drainage™ EIFS

Conceptual Details

Corporate • P.O. Box 397 • Fortson • Georgia • 31808 • 800-755-0825 • FAX 706-569-6704

Technical • 800-760-2861 • FAX 734-433-0930

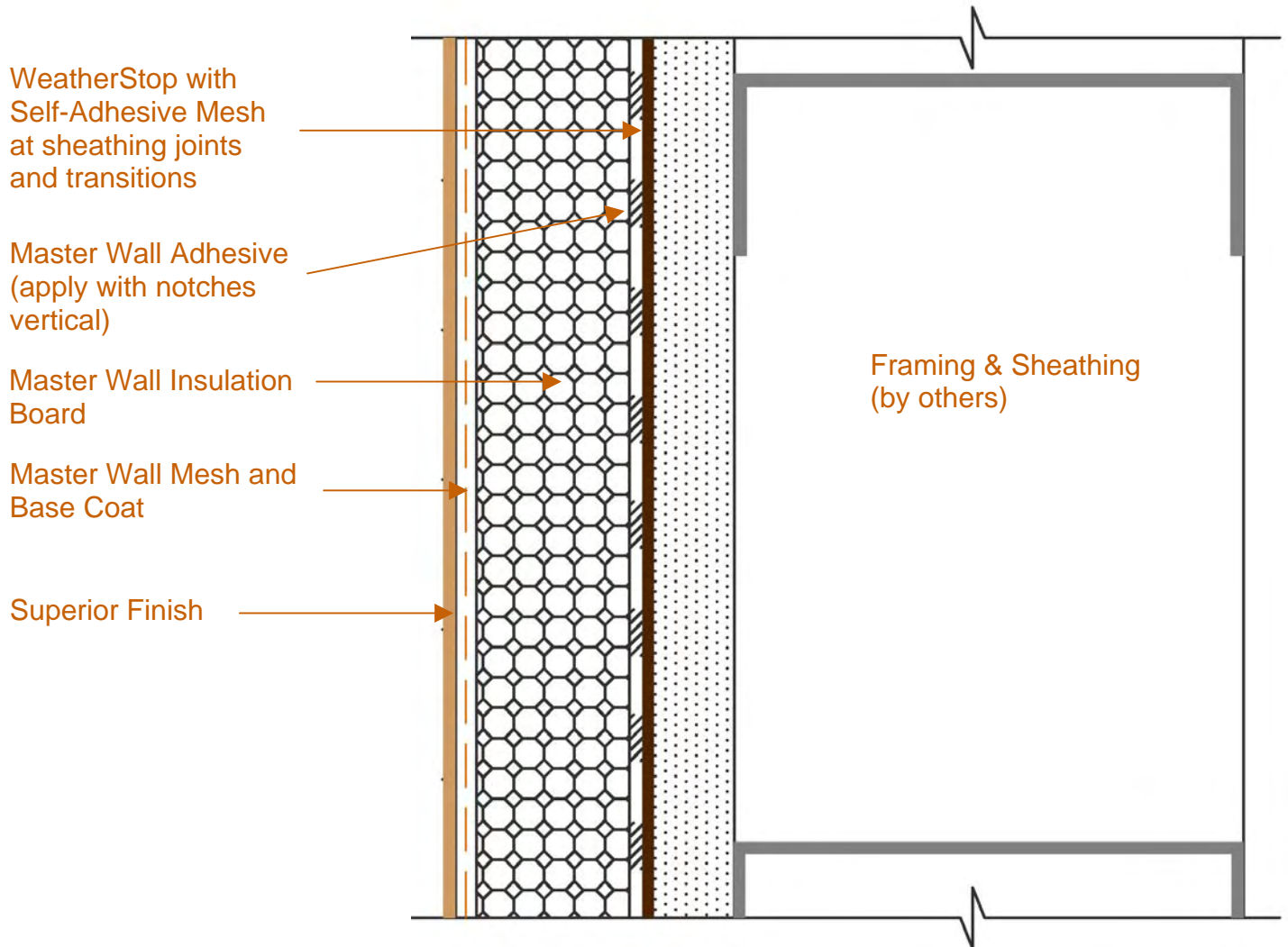

AFCD-01 Cross-Section

These drawings relay the conceptual conditions of Master Wall Systems and are not the construction drawings. Ultimately the design and detailing of an entire wall system is the responsibility of a professional. These details will guide the design professional in the use of Master Wall Products. Master Wall disclaims design, warranty or construction intent or responsibility.



Commercial Drainage™ EIFS

Conceptual Details

Corporate • P.O. Box 397 • Fortson • Georgia • 31808 • 800-755-0825 • FAX 706-569-6704

Technical • 800-760-2861 • FAX 734-433-0930

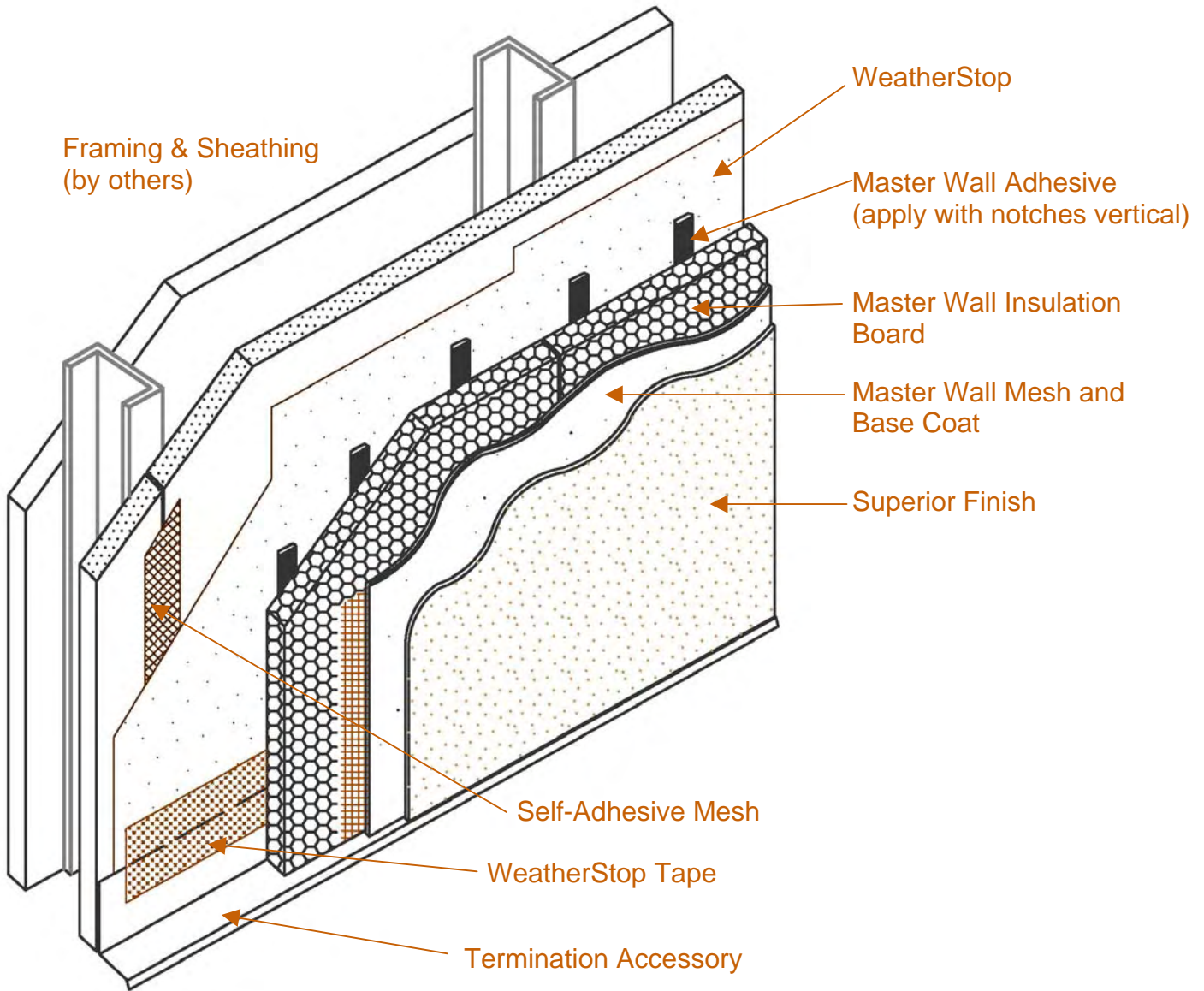

AFCD-02 Cross-Section Isometric

These drawings relay the conceptual conditions of Master Wall Systems and are not the construction drawings. Ultimately the design and detailing of an entire wall system is the responsibility of a professional. These details will guide the design professional in the use of Master Wall Products. Master Wall disclaims design, warranty or construction intent or responsibility.



Commercial Drainage™ EIFS

Conceptual Details

Corporate • P.O. Box 397 • Fortson • Georgia • 31808 • 800-755-0825 • FAX 706-569-6704

Technical • 800-760-2861 • FAX 734-433-0930

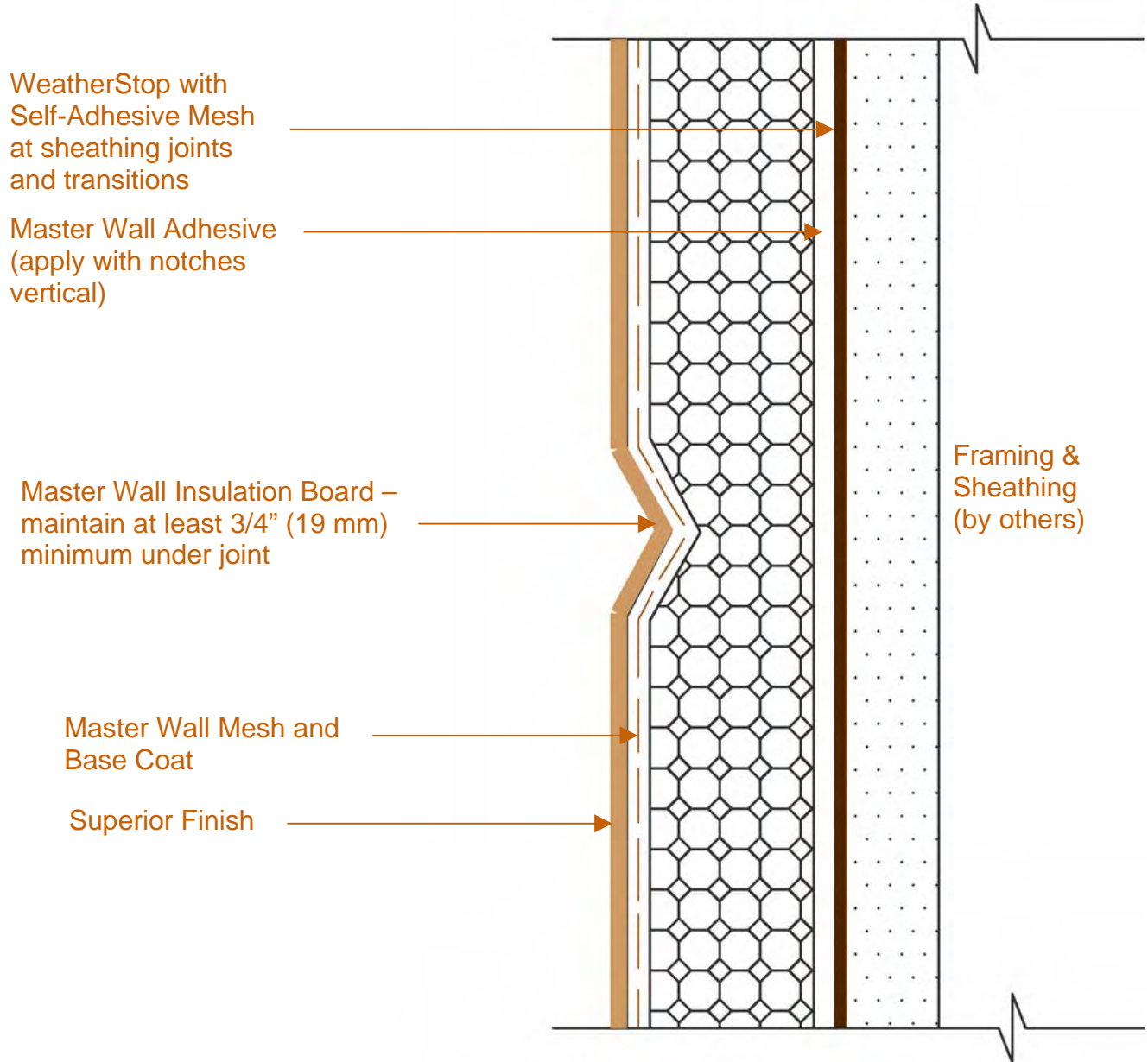

AFCD-03 Aesthetic Joint

These drawings relay the conceptual conditions of Master Wall Systems and are not the construction drawings. Ultimately the design and detailing of an entire wall system is the responsibility of a professional. These details will guide the design professional in the use of Master Wall Products. Master Wall disclaims design, warranty or construction intent or responsibility.



Commercial Drainage™ EIFS

Conceptual Details

Corporate • P.O. Box 397 • Fortson • Georgia • 31808 • 800-755-0825 • FAX 706-569-6704

Technical • 800-760-2861 • FAX 734-433-0930

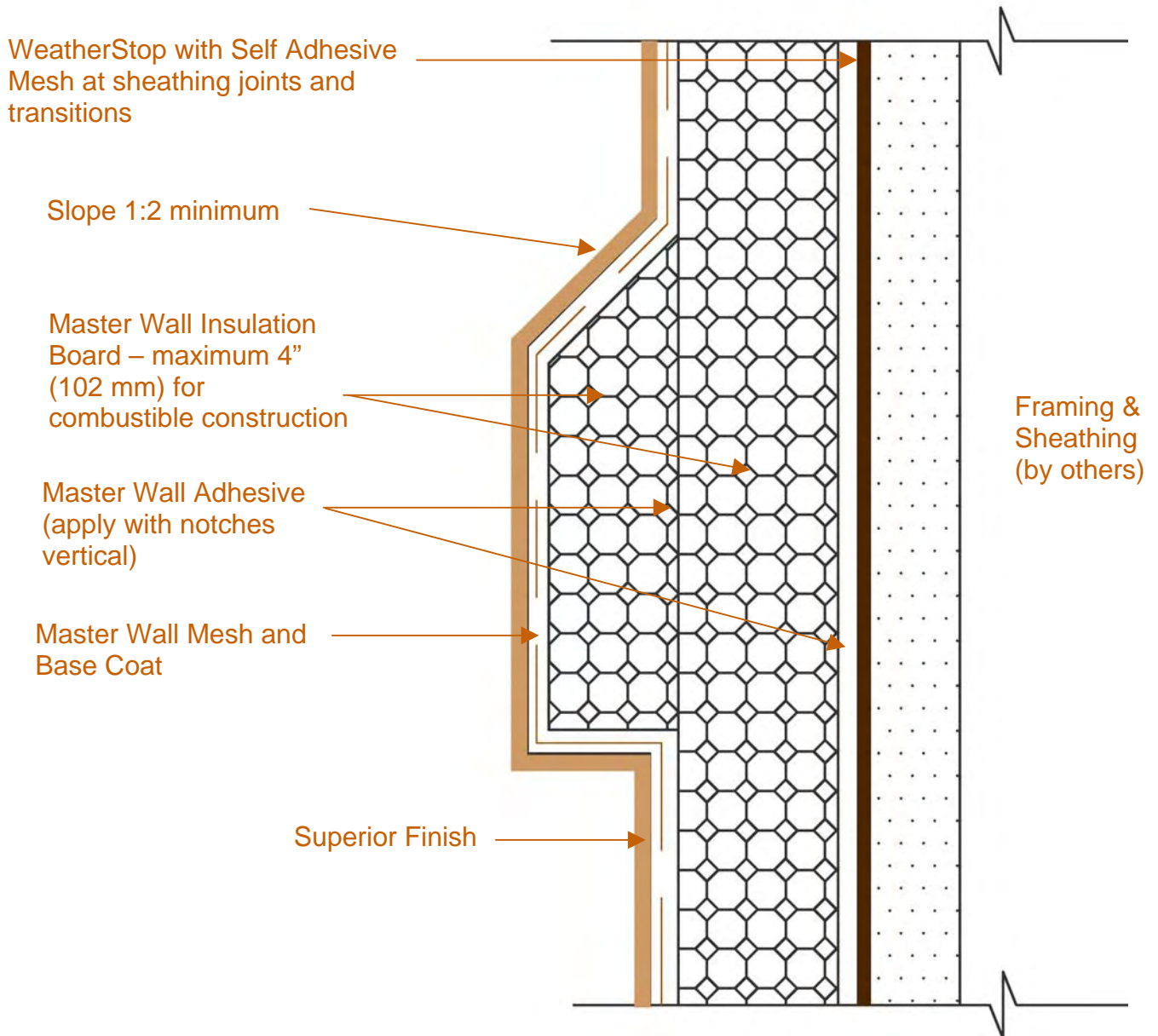

AFCD-04 Aesthetic Projection

These drawings relay the conceptual conditions of Master Wall Systems and are not the construction drawings. Ultimately the design and detailing of an entire wall system is the responsibility of a professional. These details will guide the design professional in the use of Master Wall Products. Master Wall disclaims design, warranty or construction intent or responsibility.



Commercial Drainage™ EIFS

Conceptual Details

Corporate • P.O. Box 397 • Fortson • Georgia • 31808 • 800-755-0825 • FAX 706-569-6704

Technical • 800-760-2861 • FAX 734-433-0930

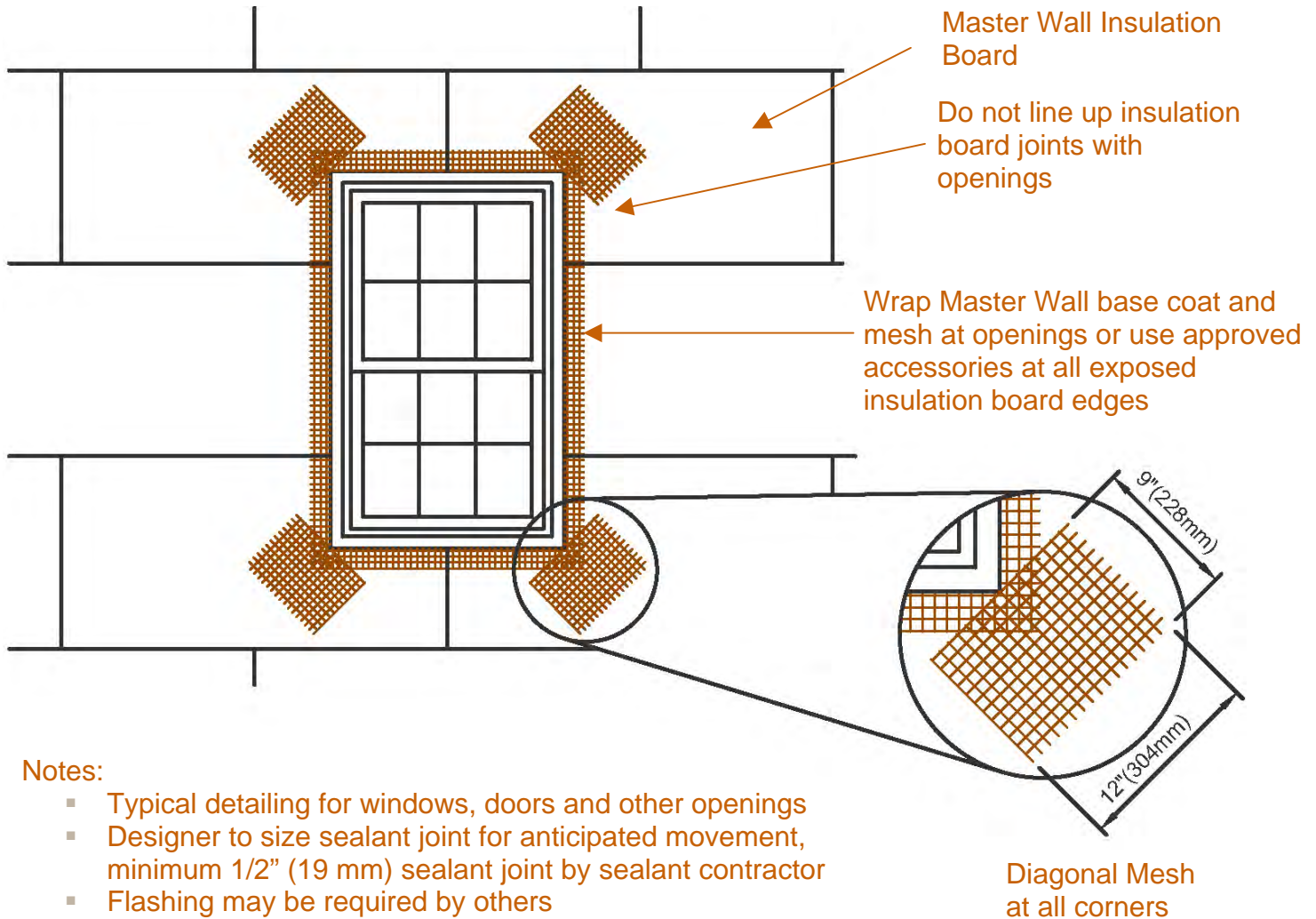

Notes:

- Typical detailing for windows, doors and other openings
- Designer to size sealant joint for anticipated movement, minimum 1/2" (19 mm) sealant joint by sealant contractor
- Flashing may be required by others

AFCD-05 Typical Reinforcing Mesh Application

These drawings relay the conceptual conditions of Master Wall Systems and are not the construction drawings. Ultimately the design and detailing of an entire wall system is the responsibility of a professional. These details will guide the design professional in the use of Master Wall Products. Master Wall disclaims design, warranty or construction intent or responsibility.



Commercial Drainage™ EIFS

Conceptual Details

Corporate • P.O. Box 397 • Fortson • Georgia • 31808 • 800-755-0825 • FAX 706-569-6704

Technical • 800-760-2861 • FAX 734-433-0930

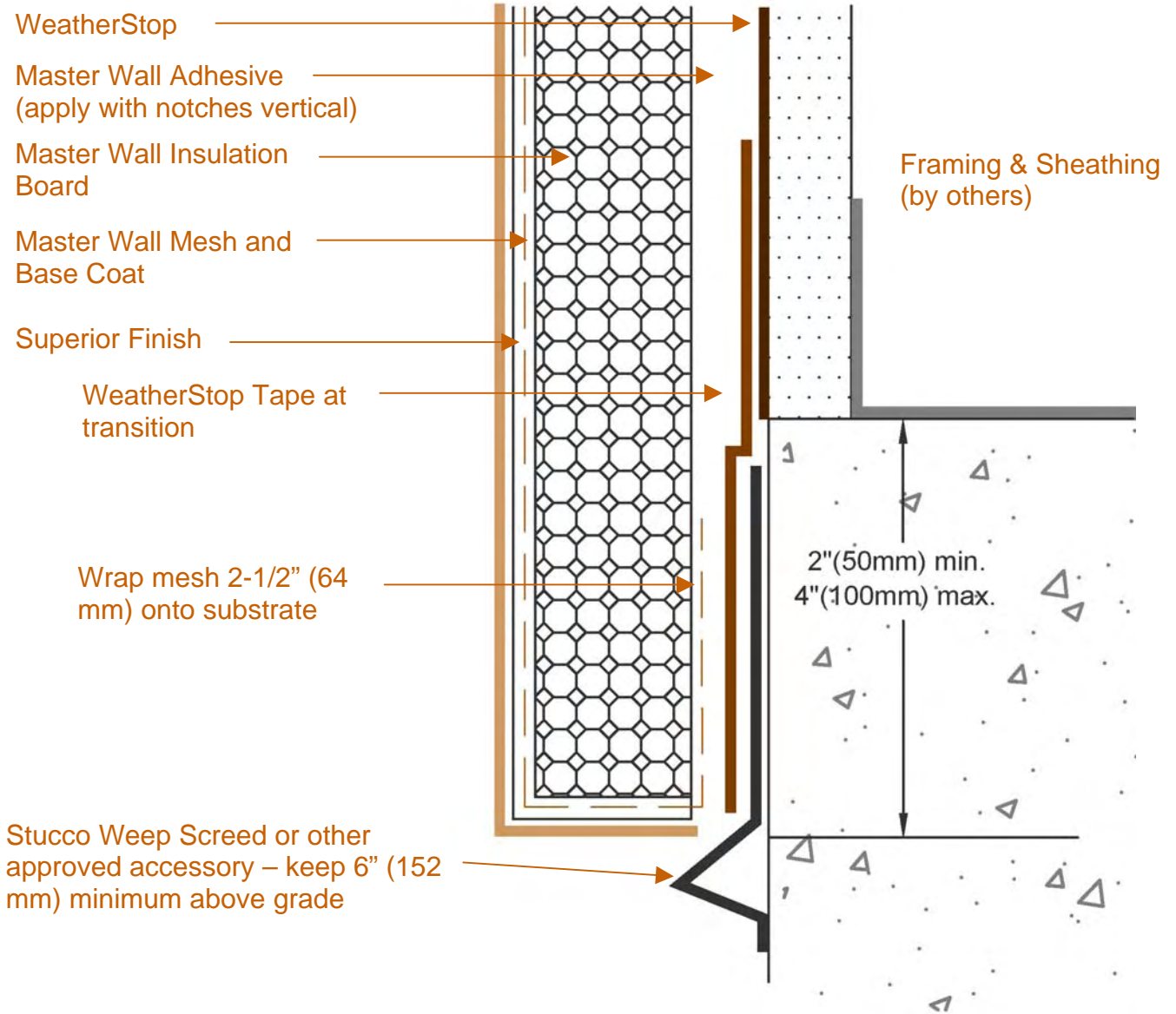

AFCD-06 Termination at Foundation

These drawings relay the conceptual conditions of Master Wall Systems and are not the construction drawings. Ultimately the design and detailing of an entire wall system is the responsibility of a professional. These details will guide the design professional in the use of Master Wall Products. Master Wall disclaims design, warranty or construction intent or responsibility.



Commercial Drainage™ EIFS

Conceptual Details

Corporate • P.O. Box 397 • Fortson • Georgia • 31808 • 800-755-0825 • FAX 706-569-6704

Technical • 800-760-2861 • FAX 734-433-0930

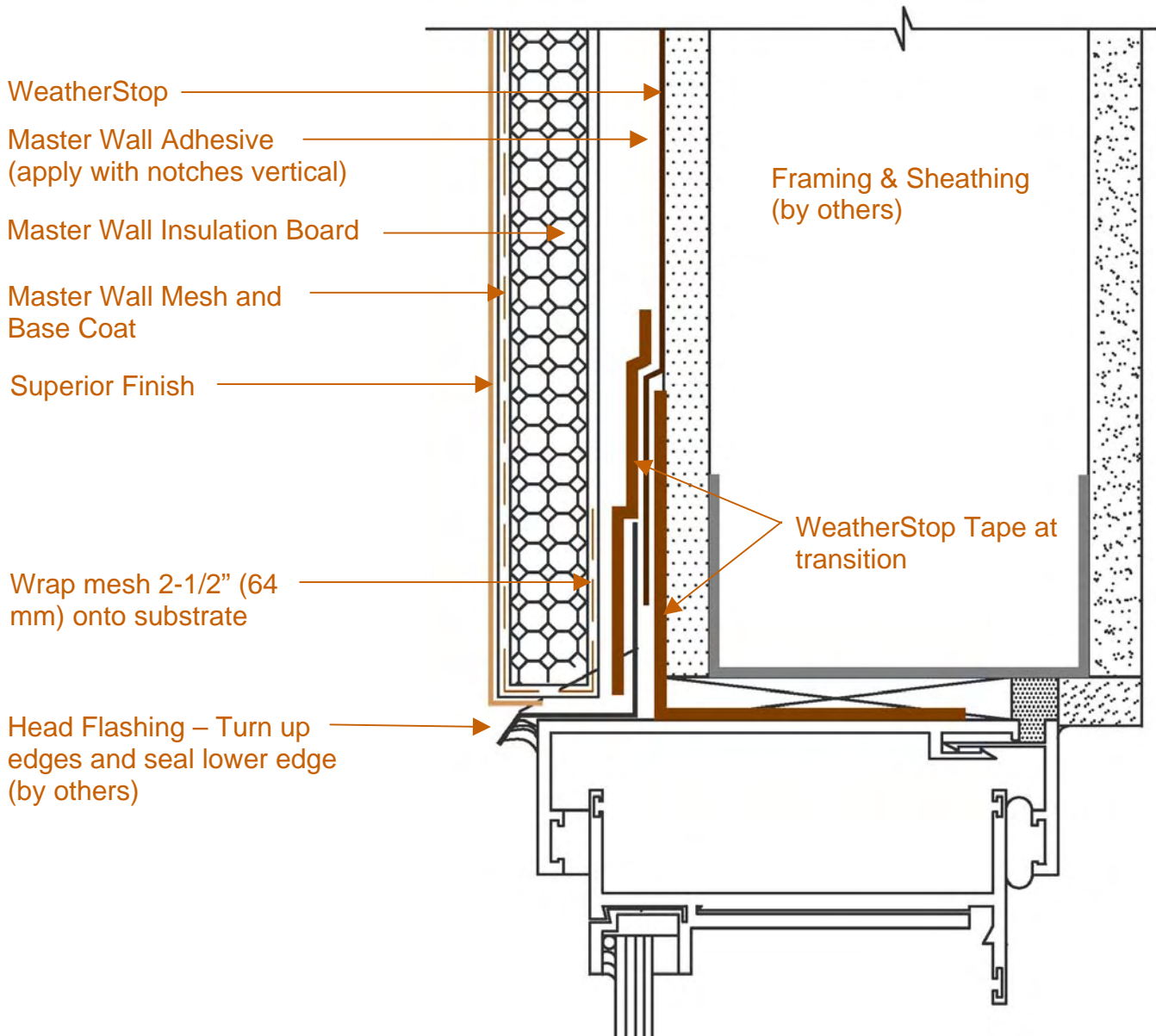

AFCD-07 Typical Window Head Detail

These drawings relay the conceptual conditions of Master Wall Systems and are not the construction drawings. Ultimately the design and detailing of an entire wall system is the responsibility of a professional. These details will guide the design professional in the use of Master Wall Products. Master Wall disclaims design, warranty or construction intent or responsibility.



Commercial Drainage™ EIFS

Conceptual Details

Corporate • P.O. Box 397 • Fortson • Georgia • 31808 • 800-755-0825 • FAX 706-569-6704

Technical • 800-760-2861 • FAX 734-433-0930

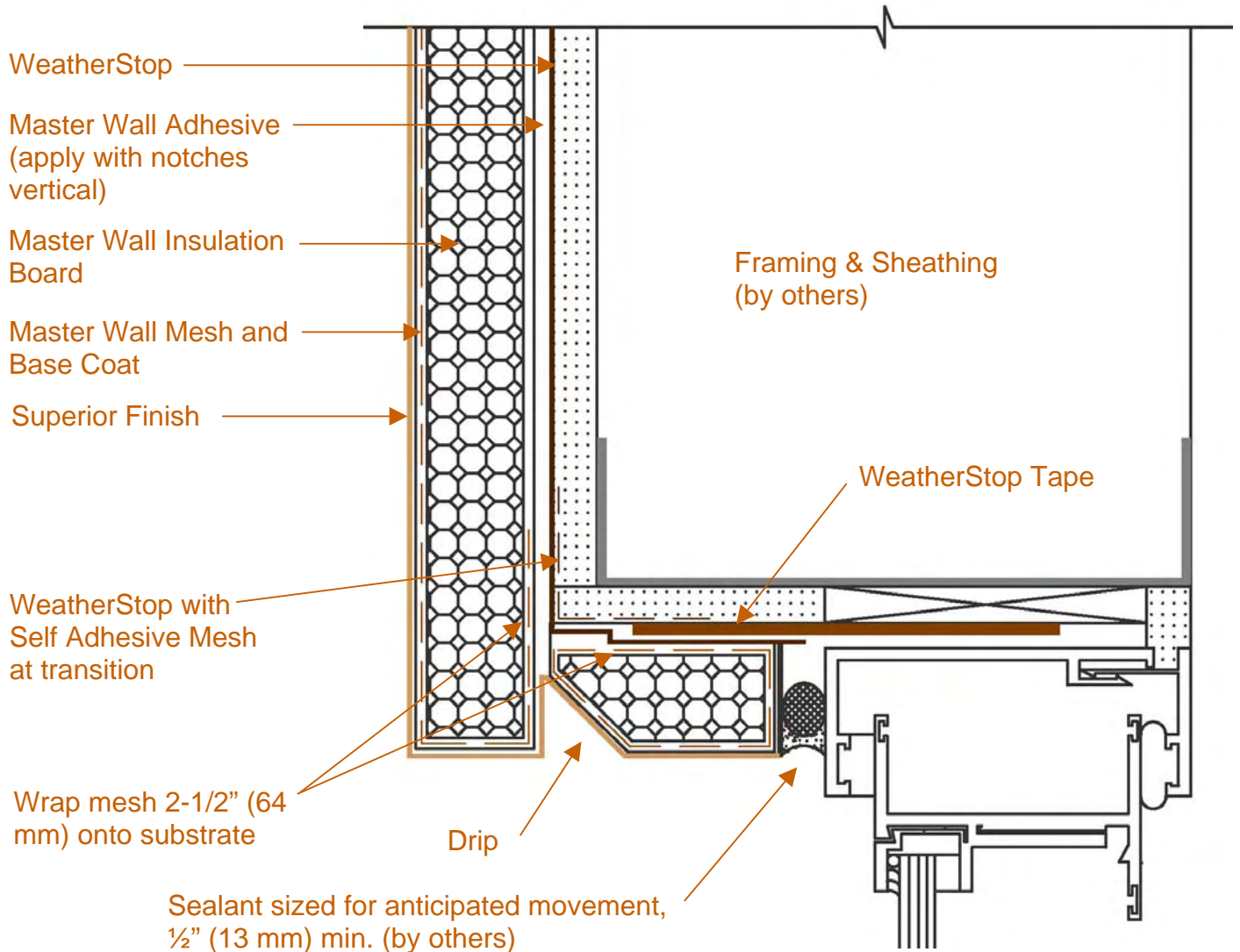

AFCD-08 Recessed Window Head Detail

These drawings relay the conceptual conditions of Master Wall Systems and are not the construction drawings. Ultimately the design and detailing of an entire wall system is the responsibility of a professional. These details will guide the design professional in the use of Master Wall Products. Master Wall disclaims design, warranty or construction intent or responsibility.



Commercial Drainage™ EIFS

Conceptual Details

Corporate • P.O. Box 397 • Fortson • Georgia • 31808 • 800-755-0825 • FAX 706-569-6704

Technical • 800-760-2861 • FAX 734-433-0930

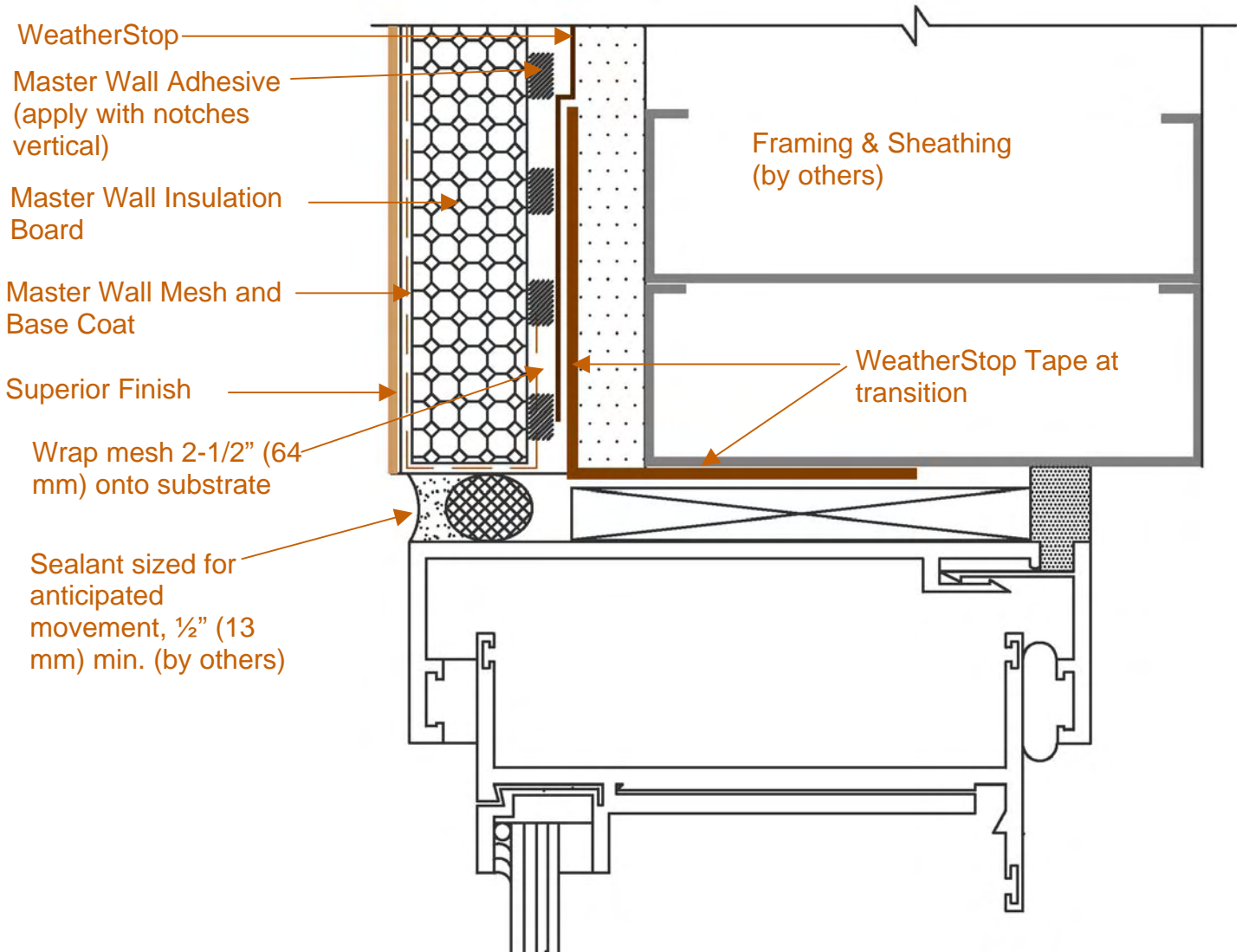

AFCD-09 Typical Jamb Detail

These drawings relay the conceptual conditions of Master Wall Systems and are not the construction drawings. Ultimately the design and detailing of an entire wall system is the responsibility of a professional. These details will guide the design professional in the use of Master Wall Products. Master Wall disclaims design, warranty or construction intent or responsibility.



Commercial Drainage™ EIFS

Conceptual Details

Corporate • P.O. Box 397 • Fortson • Georgia • 31808 • 800-755-0825 • FAX 706-569-6704

Technical • 800-760-2861 • FAX 734-433-0930

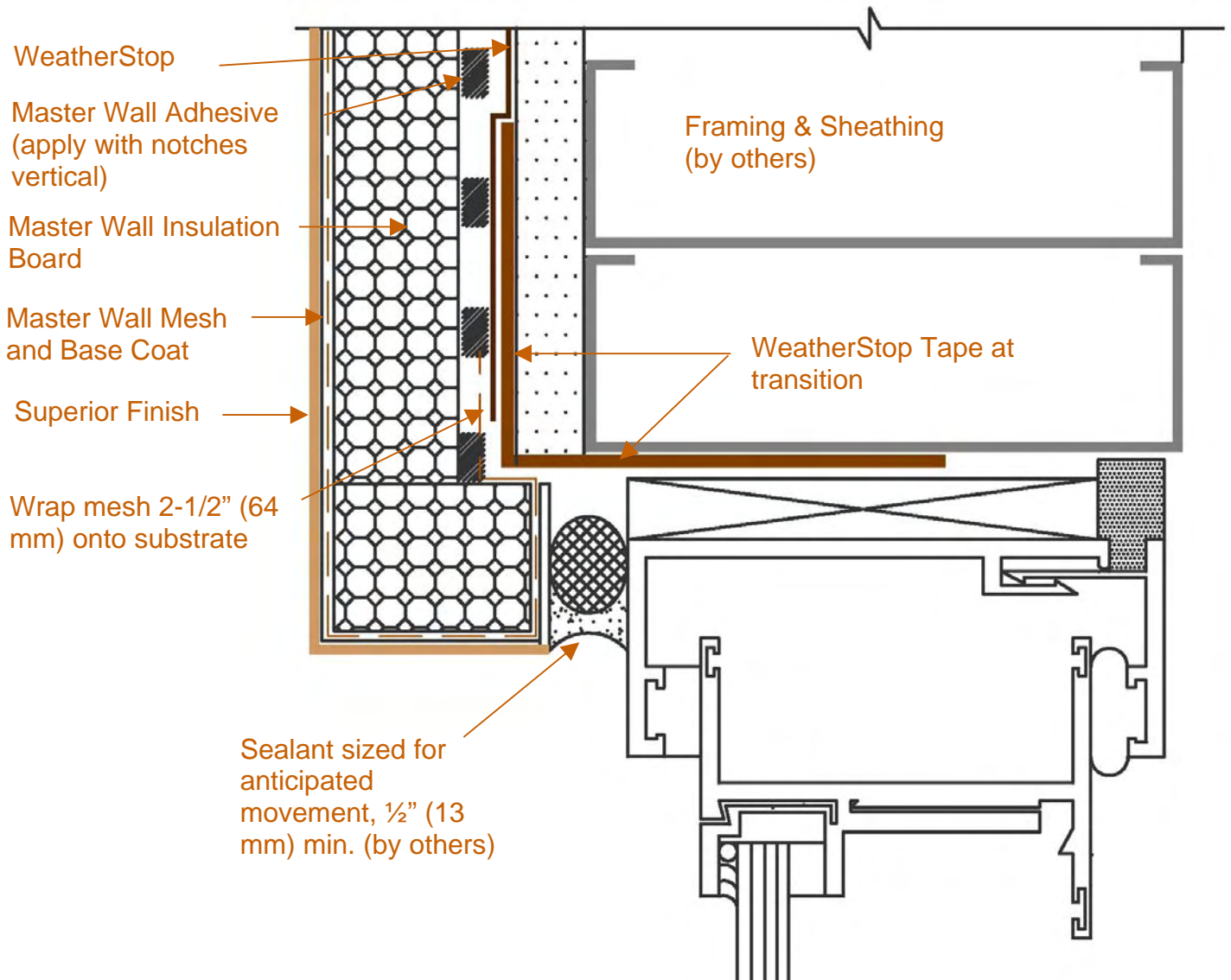

AFCD-10 Typical Jamb Detail

These drawings relay the conceptual conditions of Master Wall Systems and are not the construction drawings. Ultimately the design and detailing of an entire wall system is the responsibility of a professional. These details will guide the design professional in the use of Master Wall Products. Master Wall disclaims design, warranty or construction intent or responsibility.



Commercial Drainage™ EIFS

Conceptual Details

Corporate • P.O. Box 397 • Fortson • Georgia • 31808 • 800-755-0825 • FAX 706-569-6704

Technical • 800-760-2861 • FAX 734-433-0930

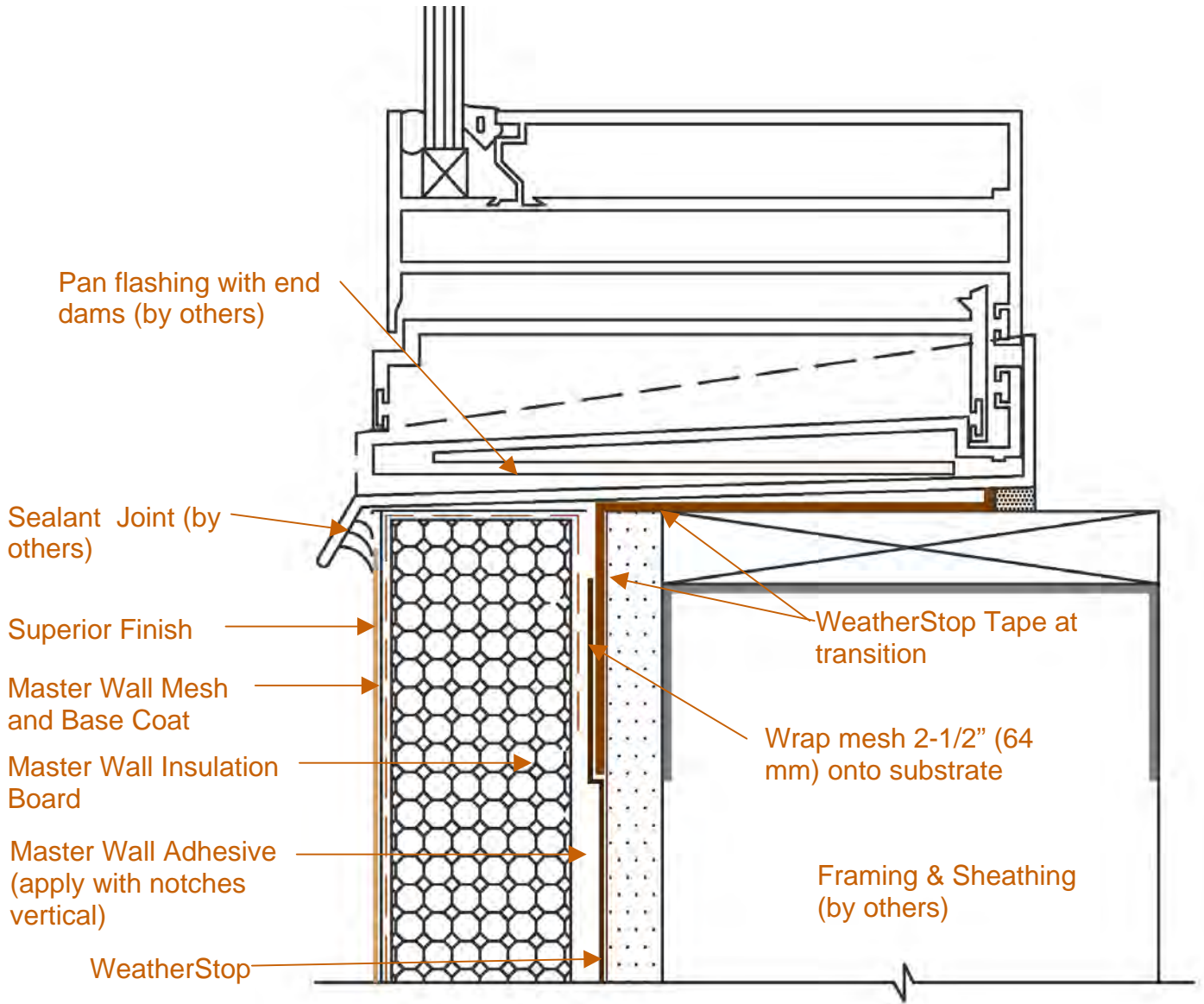

AFCD-11 Typical Sill Detail

These drawings relay the conceptual conditions of Master Wall Systems and are not the construction drawings. Ultimately the design and detailing of an entire wall system is the responsibility of a professional. These details will guide the design professional in the use of Master Wall Products. Master Wall disclaims design, warranty or construction intent or responsibility.



Commercial Drainage™ EIFS

Conceptual Details

Corporate • P.O. Box 397 • Fortson • Georgia • 31808 • 800-755-0825 • FAX 706-569-6704

Technical • 800-760-2861 • FAX 734-433-0930

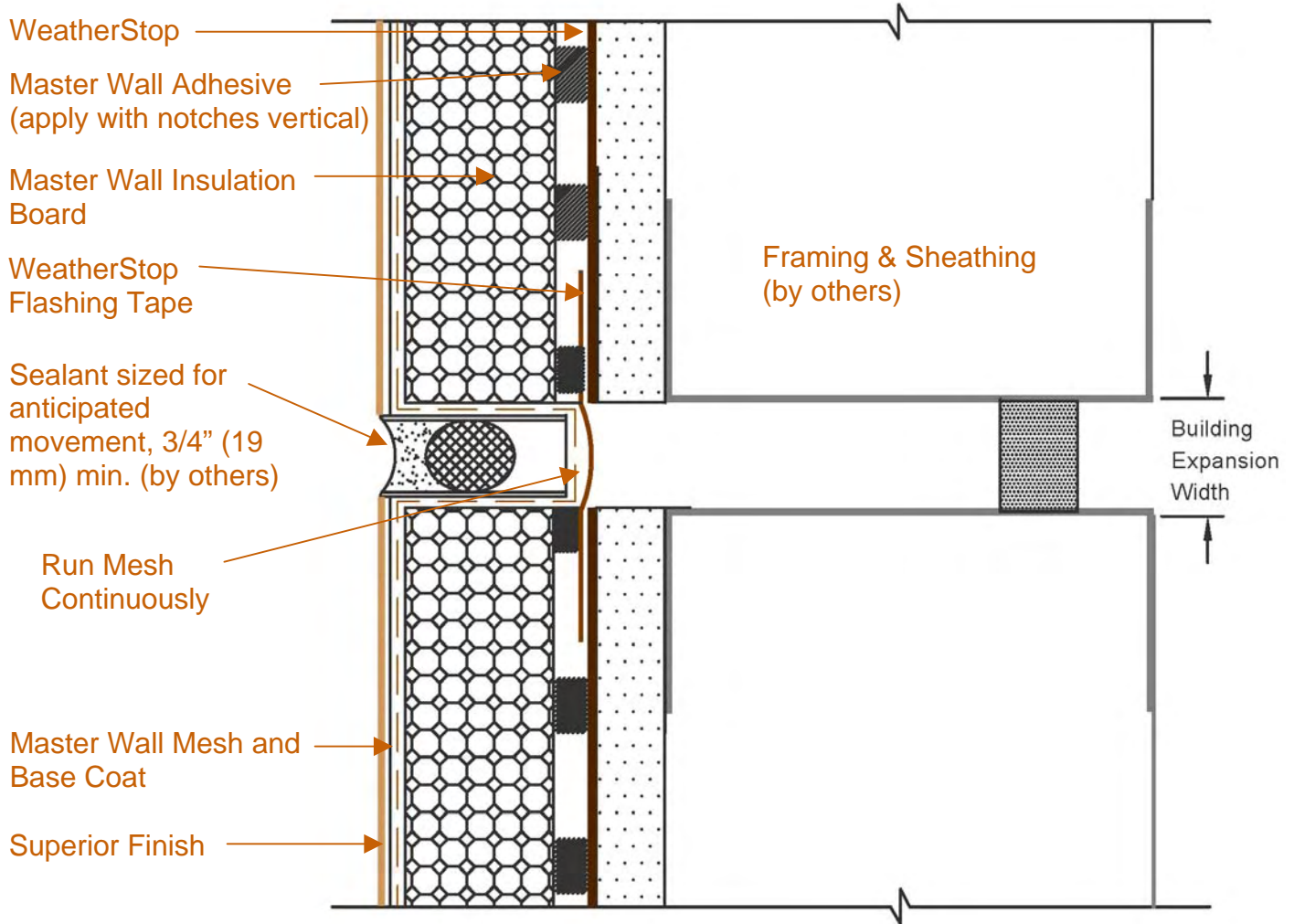

AFCD-12 Typical Vertical Expansion Joint

These drawings relay the conceptual conditions of Master Wall Systems and are not the construction drawings. Ultimately the design and detailing of an entire wall system is the responsibility of a professional. These details will guide the design professional in the use of Master Wall Products. Master Wall disclaims design, warranty or construction intent or responsibility.



Commercial Drainage™ EIFS

Conceptual Details

Corporate • P.O. Box 397 • Fortson • Georgia • 31808 • 800-755-0825 • FAX 706-569-6704

Technical • 800-760-2861 • FAX 734-433-0930

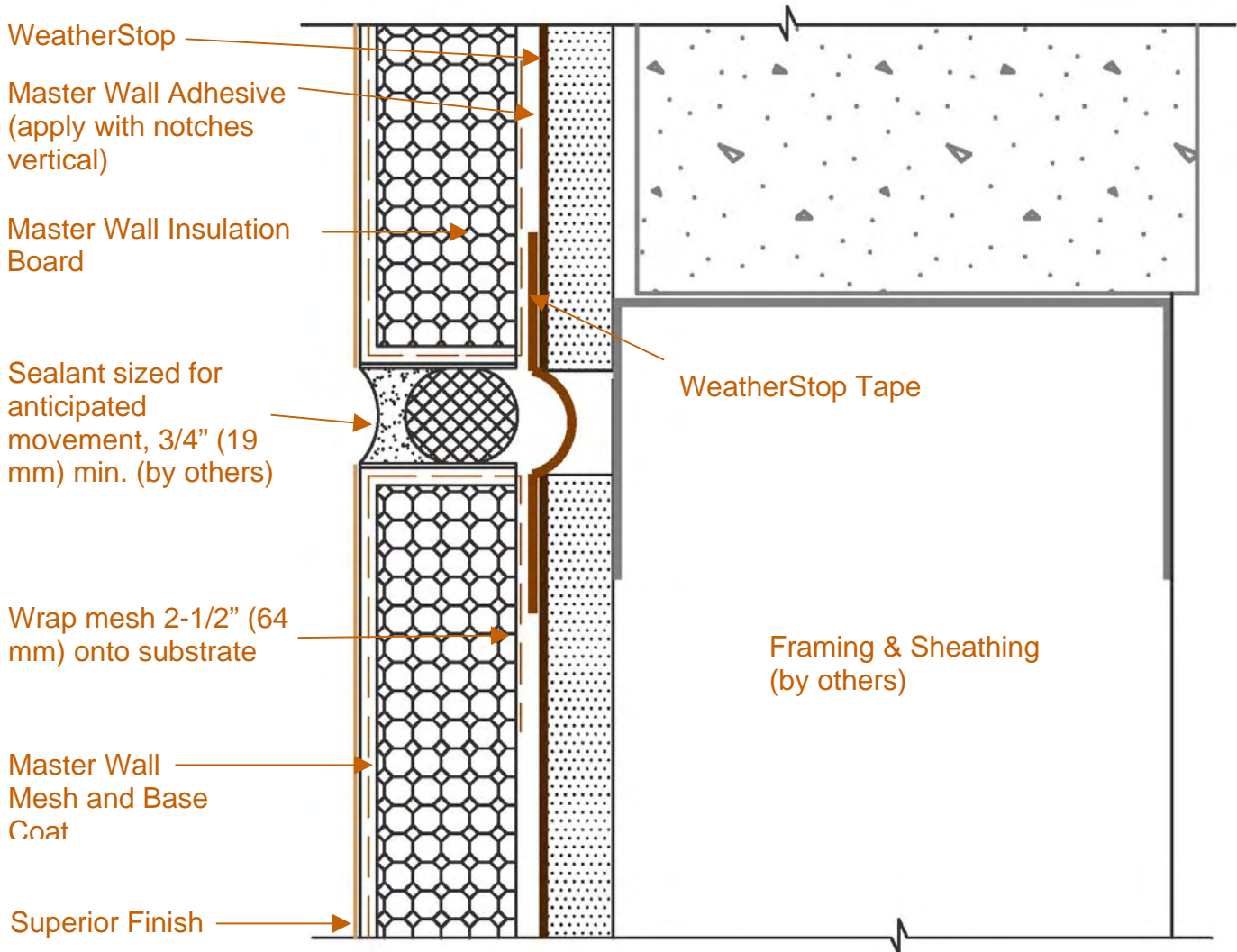

AFCD-13 Typical Horizontal Expansion Joint

These drawings relay the conceptual conditions of Master Wall Systems and are not the construction drawings. Ultimately the design and detailing of an entire wall system is the responsibility of a professional. These details will guide the design professional in the use of Master Wall Products. Master Wall disclaims design, warranty or construction intent or responsibility.



Commercial Drainage™ EIFS

Conceptual Details

Corporate • P.O. Box 397 • Fortson • Georgia • 31808 • 800-755-0825 • FAX 706-569-6704

Technical • 800-760-2861 • FAX 734-433-0930

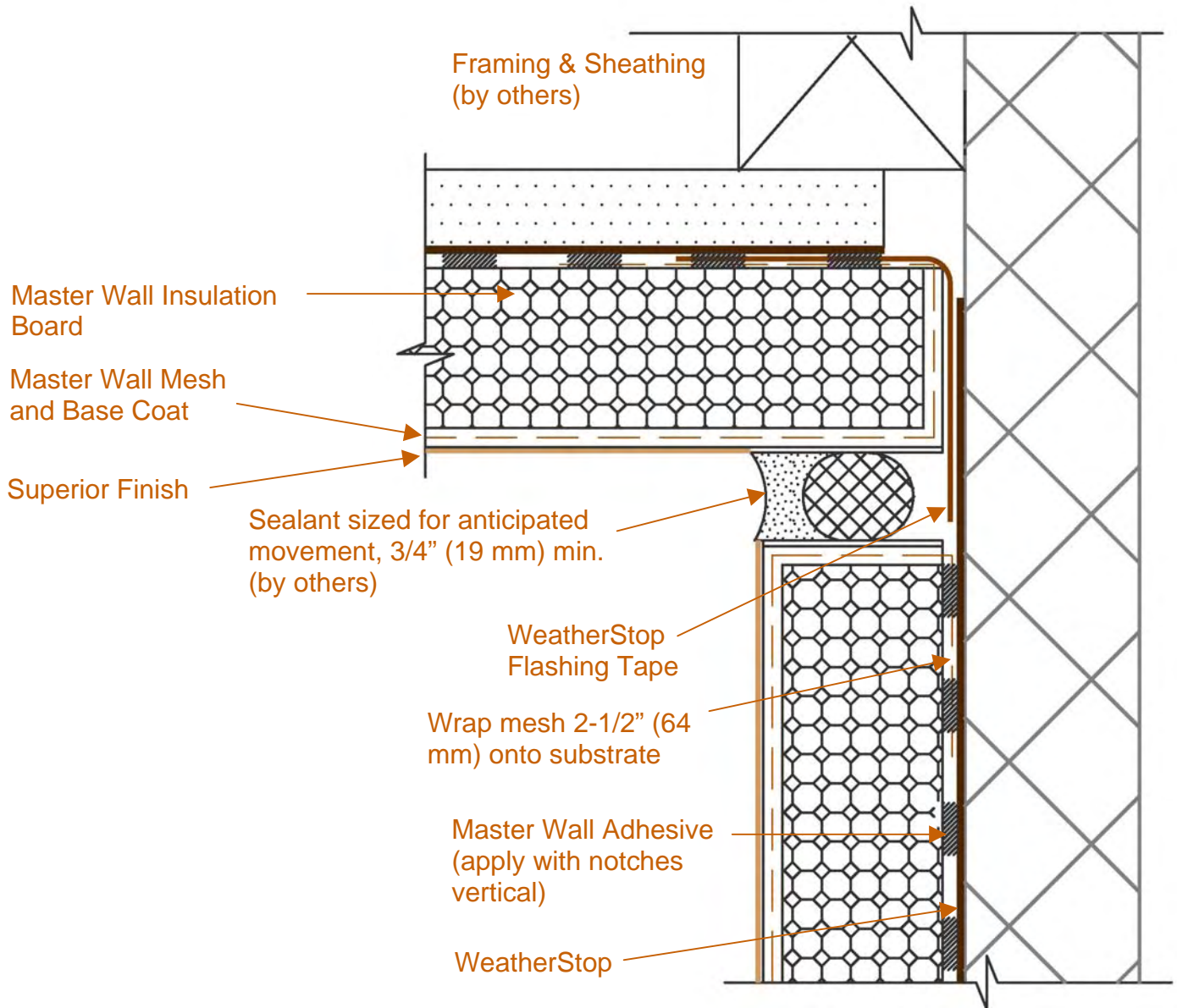

AFCD-14 Corner Expansion Joint/Substrate Change

These drawings relay the conceptual conditions of Master Wall Systems and are not the construction drawings. Ultimately the design and detailing of an entire wall system is the responsibility of a professional. These details will guide the design professional in the use of Master Wall Products. Master Wall disclaims design, warranty or construction intent or responsibility.



Commercial Drainage™ EIFS

Conceptual Details

Corporate • P.O. Box 397 • Fortson • Georgia • 31808 • 800-755-0825 • FAX 706-569-6704

Technical • 800-760-2861 • FAX 734-433-0930

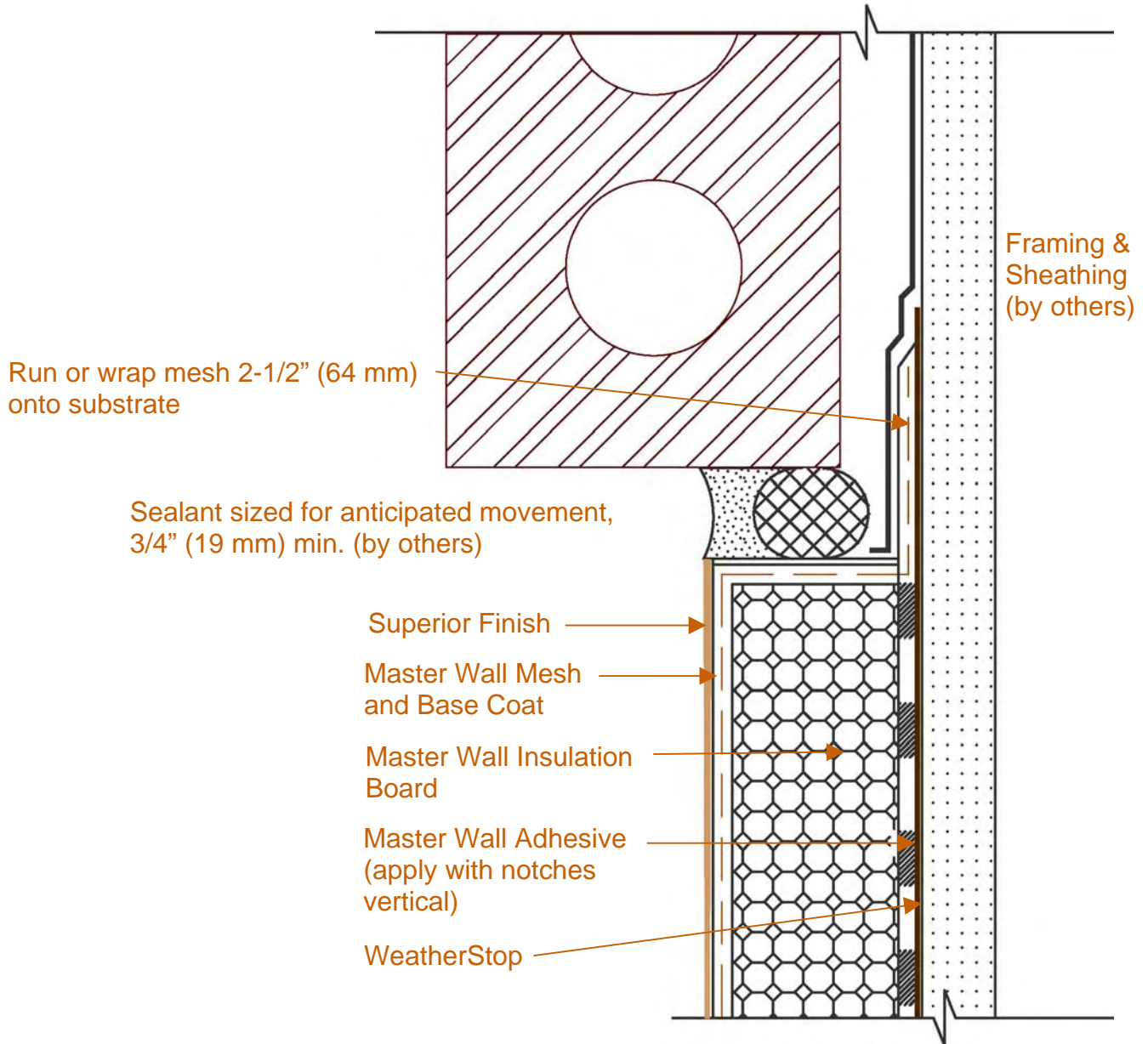

AFCD-15 Dissimilar Materials

These drawings relay the conceptual conditions of Master Wall Systems and are not the construction drawings. Ultimately the design and detailing of an entire wall system is the responsibility of a professional. These details will guide the design professional in the use of Master Wall Products. Master Wall disclaims design, warranty or construction intent or responsibility.



Commercial Drainage™ EIFS

Conceptual Details

Corporate • P.O. Box 397 • Fortson • Georgia • 31808 • 800-755-0825 • FAX 706-569-6704

Technical • 800-760-2861 • FAX 734-433-0930

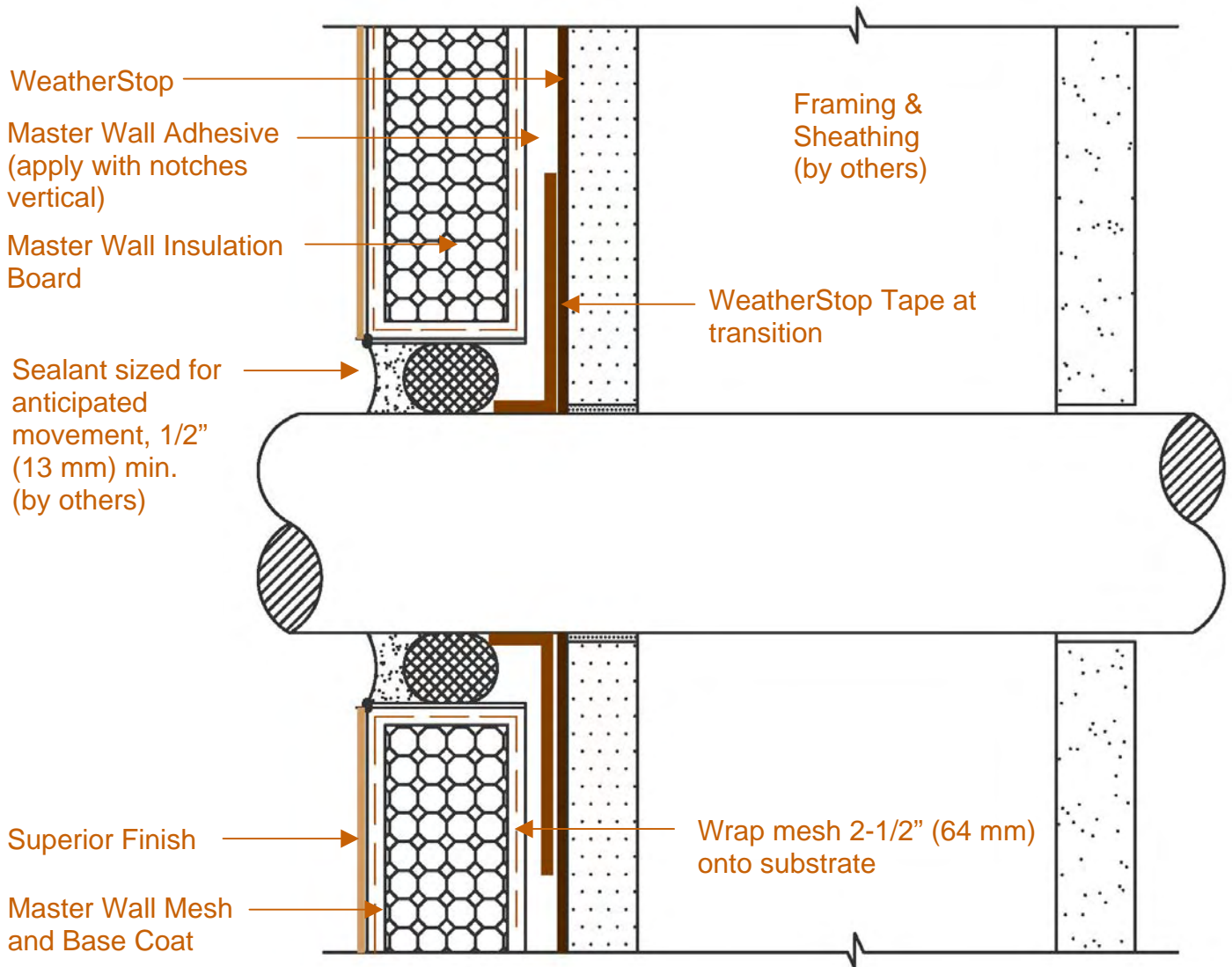

AFCD-16 Pipe Penetration Detail

These drawings relay the conceptual conditions of Master Wall Systems and are not the construction drawings. Ultimately the design and detailing of an entire wall system is the responsibility of a professional. These details will guide the design professional in the use of Master Wall Products. Master Wall disclaims design, warranty or construction intent or responsibility.



Commercial Drainage™ EIFS

Conceptual Details

Corporate • P.O. Box 397 • Fortson • Georgia • 31808 • 800-755-0825 • FAX 706-569-6704

Technical • 800-760-2861 • FAX 734-433-0930

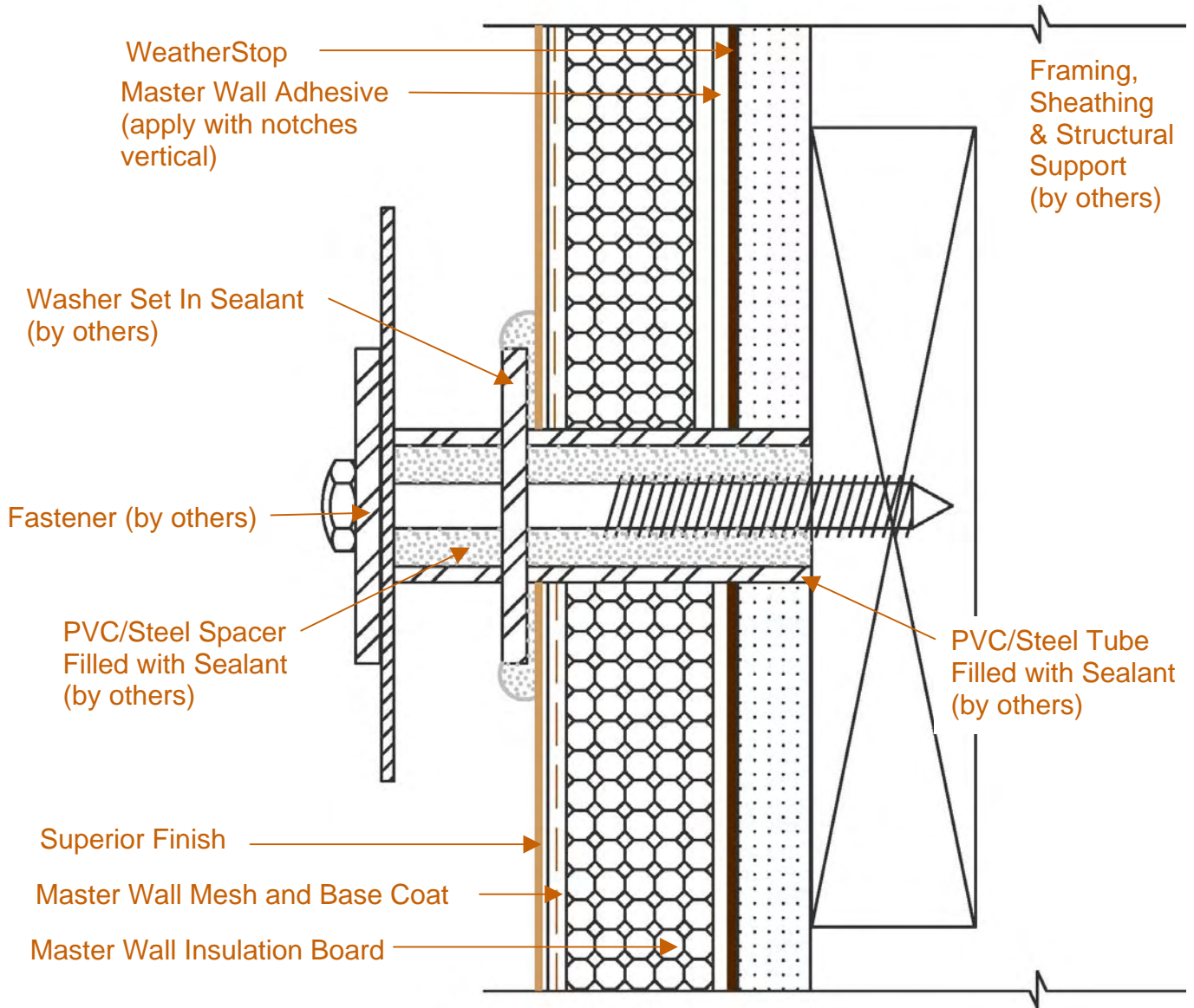

AFCD-17 Structural Fastener Detail

These drawings relay the conceptual conditions of Master Wall Systems and are not the construction drawings. Ultimately the design and detailing of an entire wall system is the responsibility of a professional. These details will guide the design professional in the use of Master Wall Products. Master Wall disclaims design, warranty or construction intent or responsibility.



Commercial Drainage™ EIFS

Conceptual Details

Corporate • P.O. Box 397 • Fortson • Georgia • 31808 • 800-755-0825 • FAX 706-569-6704

Technical • 800-760-2861 • FAX 734-433-0930

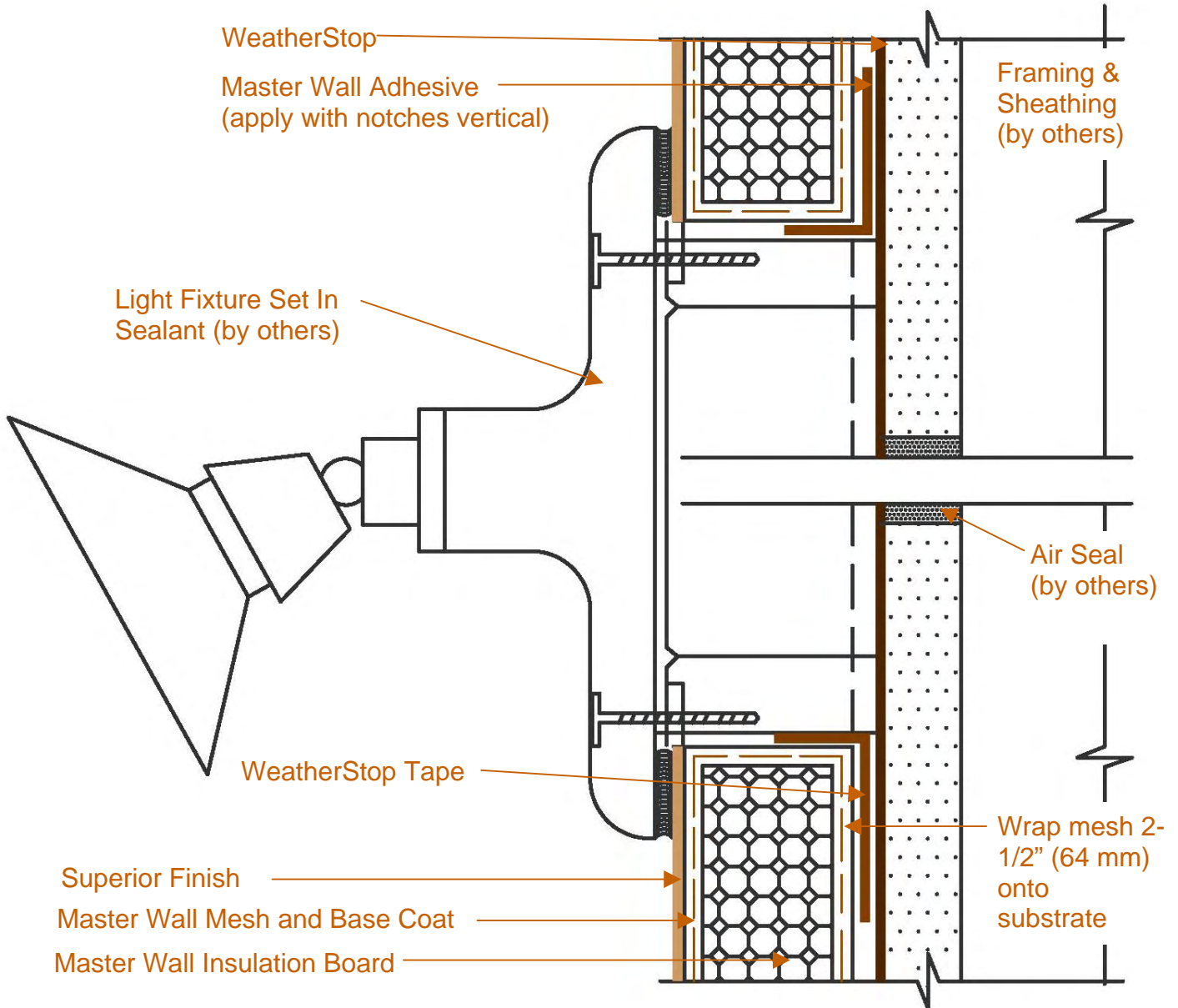

AFCD-18 Outdoor Light Fixture

These drawings relay the conceptual conditions of Master Wall Systems and are not the construction drawings. Ultimately the design and detailing of an entire wall system is the responsibility of a professional. These details will guide the design professional in the use of Master Wall Products. Master Wall disclaims design, warranty or construction intent or responsibility.



Commercial Drainage™ EIFS

Conceptual Details

Corporate • P.O. Box 397 • Fortson • Georgia • 31808 • 800-755-0825 • FAX 706-569-6704

Technical • 800-760-2861 • FAX 734-433-0930

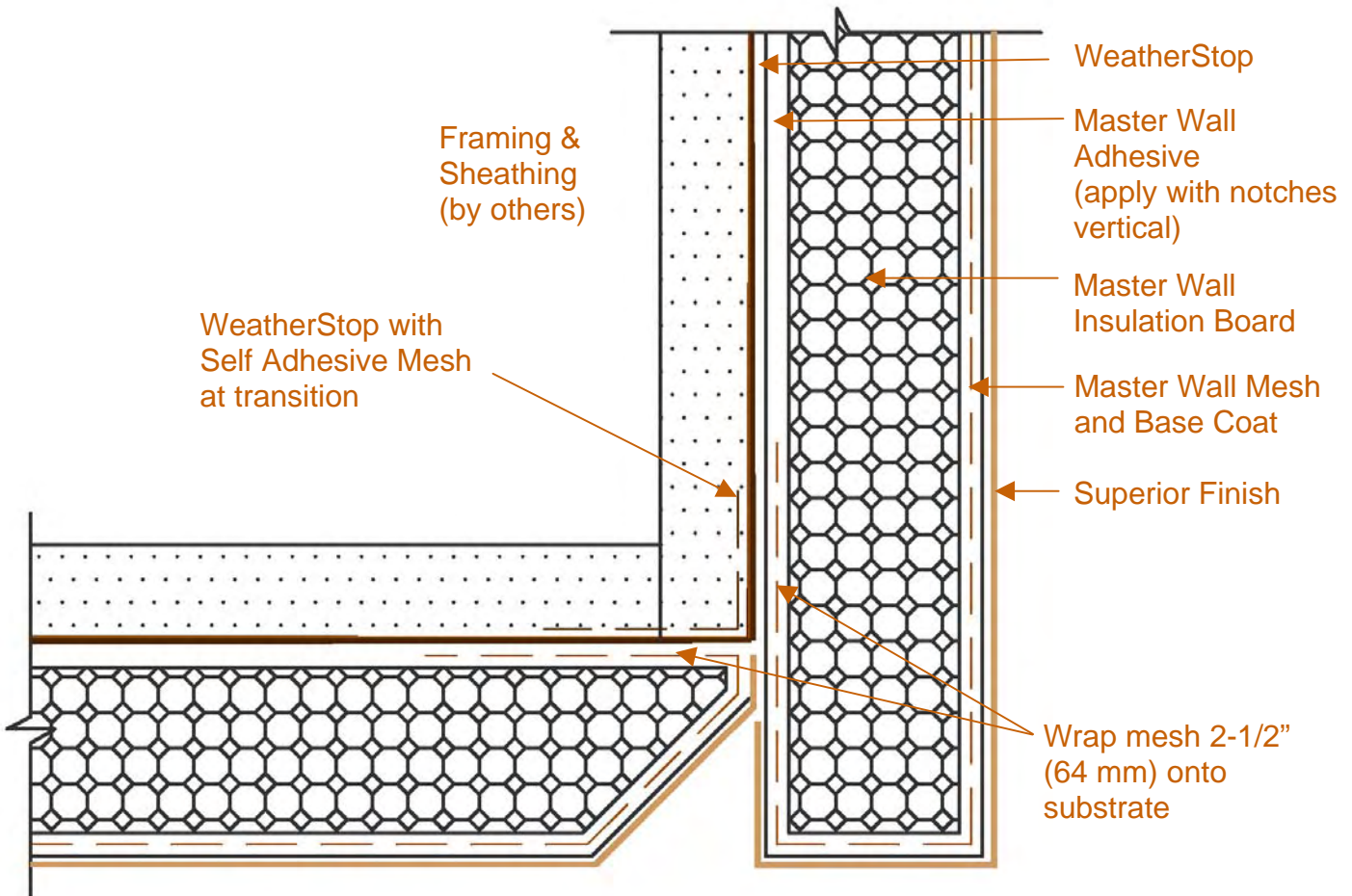

AFCD-19 Soffit/Drip Detail

These drawings relay the conceptual conditions of Master Wall Systems and are not the construction drawings. Ultimately the design and detailing of an entire wall system is the responsibility of a professional. These details will guide the design professional in the use of Master Wall Products. Master Wall disclaims design, warranty or construction intent or responsibility.



Commercial Drainage™ EIFS

Conceptual Details

Corporate • P.O. Box 397 • Fortson • Georgia • 31808 • 800-755-0825 • FAX 706-569-6704

Technical • 800-760-2861 • FAX 734-433-0930

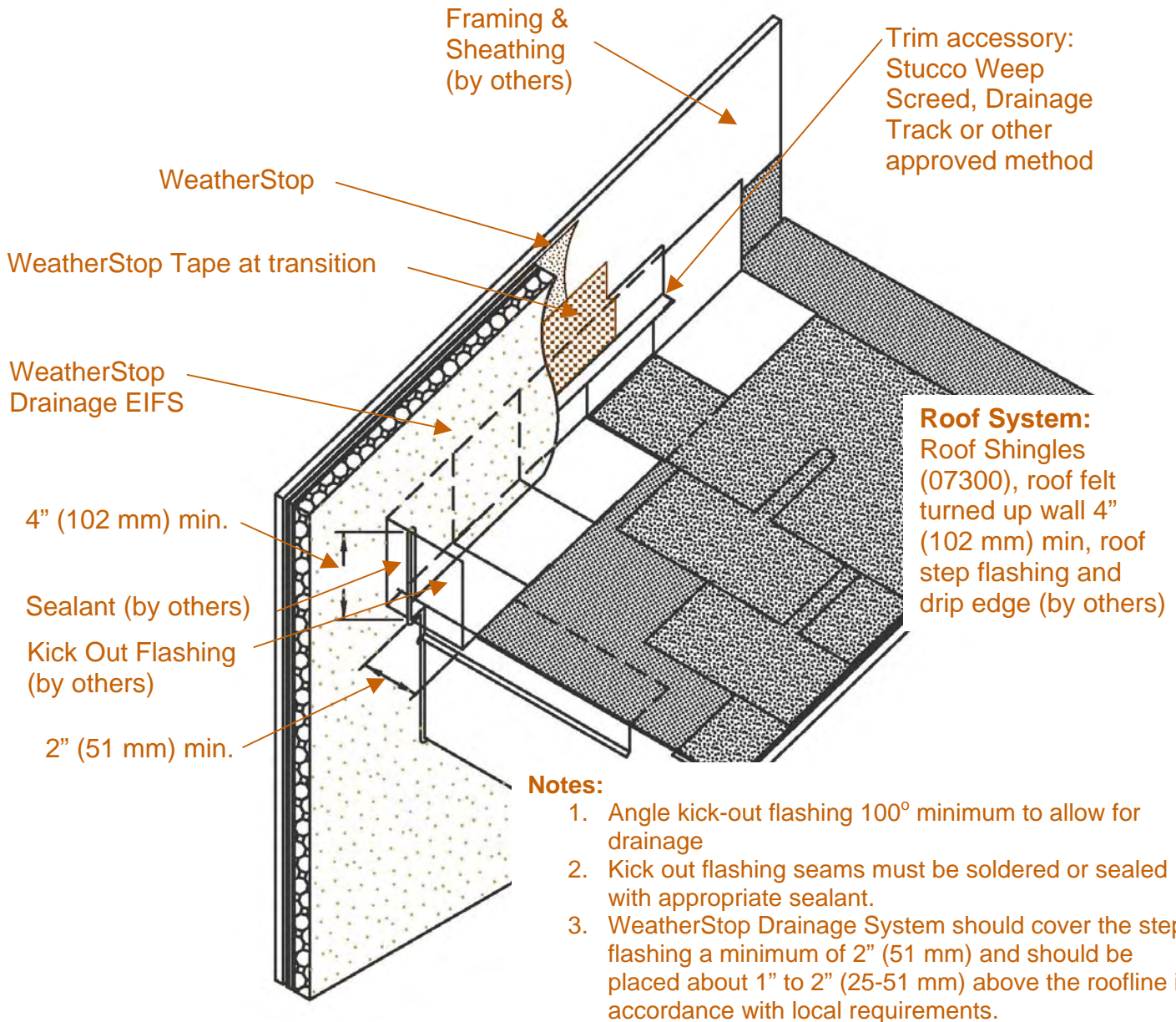

AFCD-20 Typical Roof/Wall Intersection

These drawings relay the conceptual conditions of Master Wall Systems and are not the construction drawings. Ultimately the design and detailing of an entire wall system is the responsibility of a professional. These details will guide the design professional in the use of Master Wall Products. Master Wall disclaims design, warranty or construction intent or responsibility.



Commercial Drainage™ EIFS

Conceptual Details

Corporate • P.O. Box 397 • Fortson • Georgia • 31808 • 800-755-0825 • FAX 706-569-6704

Technical • 800-760-2861 • FAX 734-433-0930

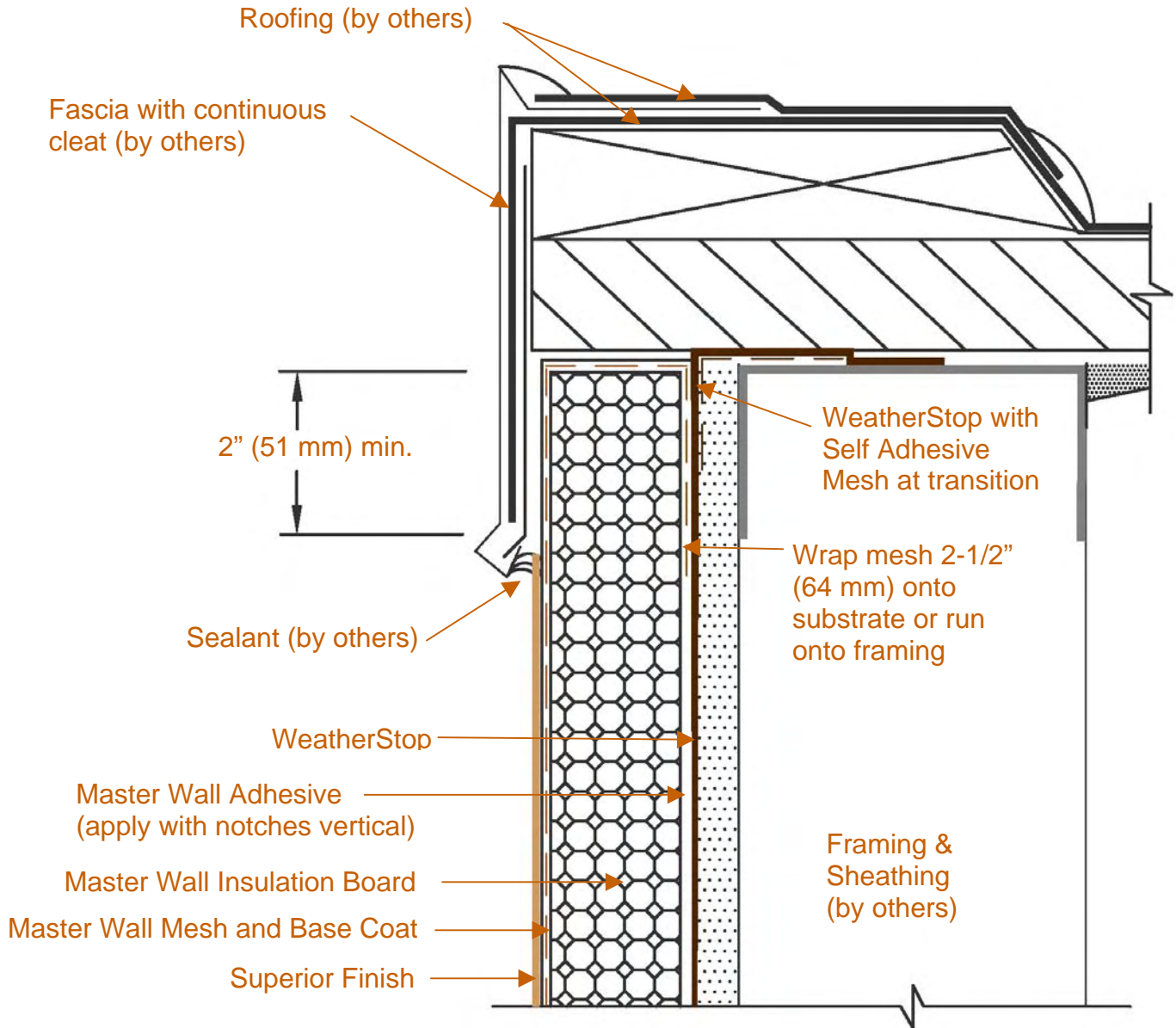

AFCD-21 Cap Detail

These drawings relay the conceptual conditions of Master Wall Systems and are not the construction drawings. Ultimately the design and detailing of an entire wall system is the responsibility of a professional. These details will guide the design professional in the use of Master Wall Products. Master Wall disclaims design, warranty or construction intent or responsibility.



Commercial Drainage™ EIFS

Conceptual Details

Corporate • P.O. Box 397 • Fortson • Georgia • 31808 • 800-755-0825 • FAX 706-569-6704

Technical • 800-760-2861 • FAX 734-433-0930

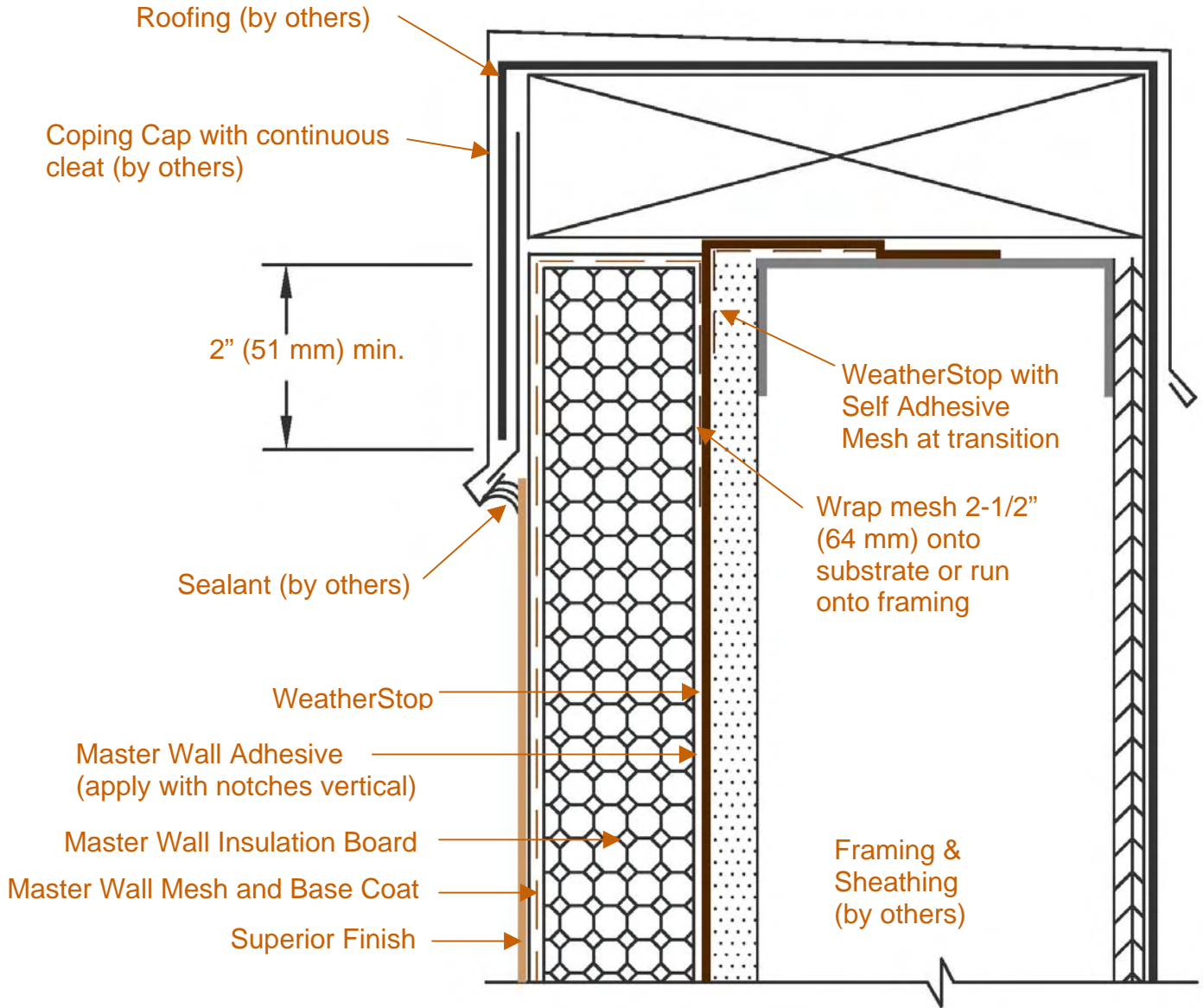

AFCD-22 Cap Detail

These drawings relay the conceptual conditions of Master Wall Systems and are not the construction drawings. Ultimately the design and detailing of an entire wall system is the responsibility of a professional. These details will guide the design professional in the use of Master Wall Products. Master Wall disclaims design, warranty or construction intent or responsibility.



Commercial Drainage™ EIFS

Conceptual Details

Corporate • P.O. Box 397 • Fortson • Georgia • 31808 • 800-755-0825 • FAX 706-569-6704

Technical • 800-760-2861 • FAX 734-433-0930

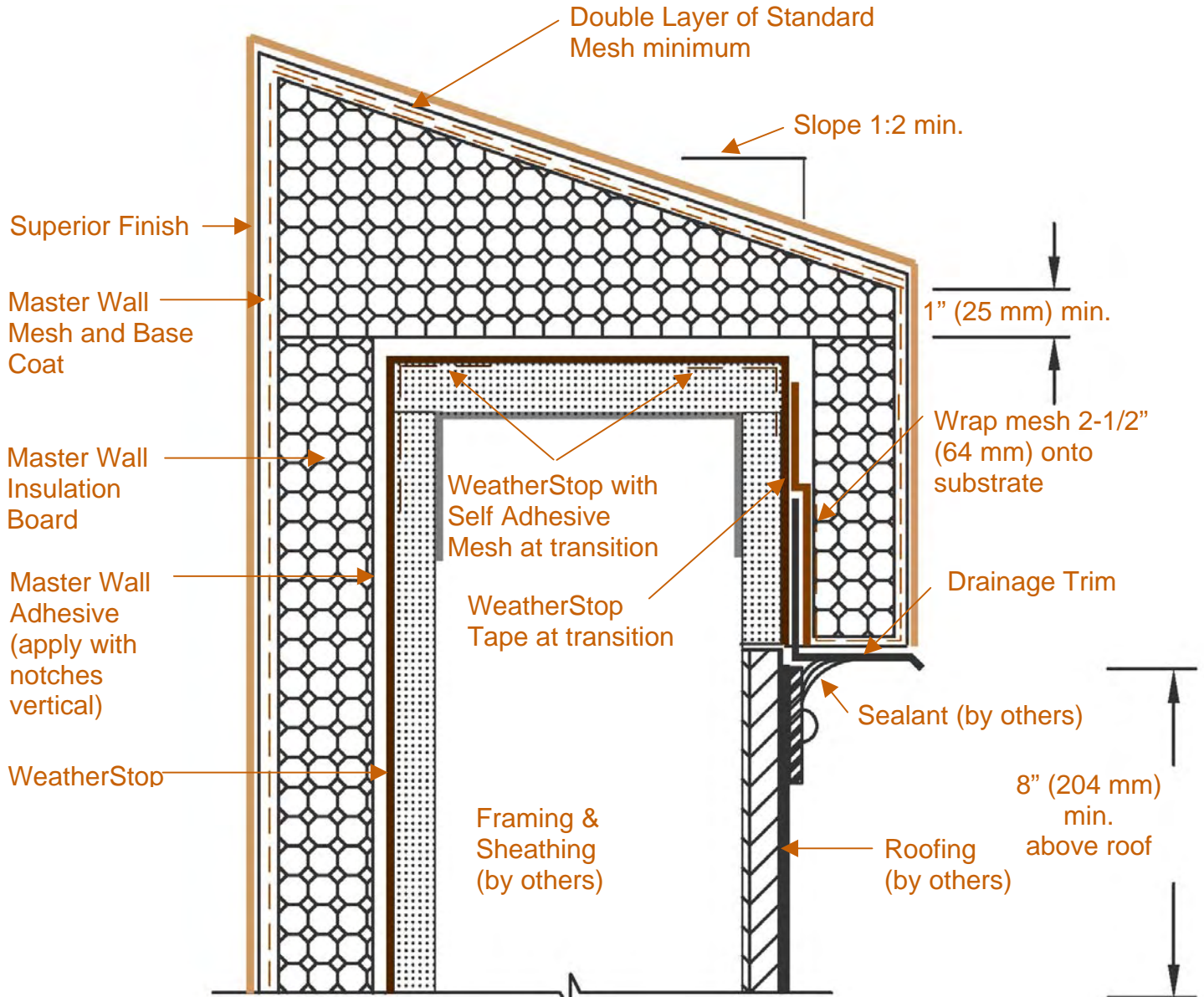

AFCD-24 Parapet Cap Detail – Max. 12" Wide

These drawings relay the conceptual conditions of Master Wall Systems and are not the construction drawings. Ultimately the design and detailing of an entire wall system is the responsibility of a professional. These details will guide the design professional in the use of Master Wall Products. Master Wall disclaims design, warranty or construction intent or responsibility.



Master Wall, Inc
Building a Culture of Excellence

Aggre-flex

Commercial Drainage EIFS

10 Year Labor & Material Limited Warranty

Master Wall Inc. warrants the properly designed and installed Aggre-flex Commercial Drainage Exterior Insulation and Finish System and materials for 10 years from the date of installation. Master Wall Inc.'s exclusive liability under this warranty is to supply replacement materials and labor or corrective procedures, if it is shown that the materials supplied by Master Wall Inc., were defective when installed by the Master Wall Inc. certified applicator. Remedies shall be solely determined by Master Wall Inc. and no other warranties are expressed or implied. For a valid warranty, the system and products must be installed in accordance with Master Wall Inc.'s written recommendations, specifications, details, bulletins and other project-specific written recommendations. Master Wall Inc. must be notified in writing within 10 business days of the original discovery of the defect.

Master Wall Inc., is not responsible for structural conditions, design conditions beyond those noted in our literature, architecture, engineering or workmanship of any project. Drainage Systems are warranted to drain incidental water for the warranty period. Materials must be properly stored and applied in a timely manner. Workmanship, aesthetics and installation are beyond the scope of this warranty as are any deviations from Master Wall Inc. Documents not specifically approved in writing.

Abuse, misuse, excessive weather or environmental conditions beyond what the products or systems have been tested, designed or approved for is expressly limited. Certain colors with organic pigments are less fade-resistant than others. The building, system and products must be properly maintained in accordance with Master Wall Inc., documents, local environmental conditions and good building practices. In no case is Master Wall Inc. responsible for incidental and consequential damages.

This warranty becomes effective only when all bills for the components of the system have been paid.

Except as stated, Master Wall, Inc., expressly disclaims any warranty of merchantability or fitness for a particular purpose. The above remedies are to be deemed exclusive.

Project:

Applicator:

Warranty Date: